

Programmable DC Power Supply

IT-M3100 Series User Manual



Model: IT-M3110/IT-M3111/IT-M3112/IT-M3113/IT-M3114/IT-M3115/IT-M3120/IT-M3121/IT-M3122/IT-M3123/IT-M3124/IT-M3125/IT-M3120S/IT-M3112S/IT-M3130/IT-M3131/IT-M3132/IT-M3133/IT-M3134/IT-M3135/IT-M3116/IT-M3126/IT-M3136

Version: V3.0 / 07 , 2025

Notices

© Itech Electronic, Co., Ltd. 2025

No part of this manual may be reproduced in any form or by any means (including electronic storage and retrieval or translation into a foreign language) without prior permission and written consent from Itech Electronic, Co., Ltd. as governed by international copyright laws.

Manual Part Number



402225

Trademarks

Pentium is U.S. registered trademarks of Intel Corporation.

Microsoft, Visual Studio, Windows and MS Windows are registered trademarks of Microsoft Corporation in the United States and/or other countries and regions.

Warranty

The materials contained in this document are provided “as is”, and is subject to change, without prior notice, in future editions. Further, to the maximum extent permitted by applicable laws, ITECH disclaims all warranties, either express or implied, with regard to this manual and any information contained herein, including but not limited to the implied warranties of merchantability and fitness for a particular purpose. ITECH shall not be held liable for errors or for incidental or indirect damages in connection with the furnishing, use or application of this document or of any information contained herein. Should ITECH and the user enter into a separate written agreement with warranty terms covering the materials in this document that conflict with these terms, the warranty terms in the separate agreement shall prevail.

Technology Licenses

The hardware and/or software described herein are furnished under a license and may be used or copied only in accordance with the terms of such license.

Restricted Rights Legend

Restricted permissions of the U.S. government. Permissions for software and technical data which are authorized to the U.S. Government only include those for custom provision to end users. ITECH follows FAR 12.211 (technical data), 12.212 (computer software). DFARS 252.227-7015 (technical data—commercial products) for national defense and DFARS 227.7202-3 (permissions for commercial computer software or computer software documents) while providing the customized business licenses of software and technical data.

Safety Notices

CAUTION

A CAUTION sign denotes a hazard. It calls attention to an operating procedure or practice that, if not correctly performed or adhered to, could result in damage to the product or loss of important data. Do not proceed beyond a CAUTION sign until the indicated conditions are fully understood and met.

WARNING

A WARNING sign denotes a hazard. It calls attention to an operating procedure or practice that, if not correctly performed or adhered to, could result in personal injury or death. Do not proceed beyond a WARNING sign until the indicated conditions are fully understood and met.



Note

A NOTE sign denotes important hint. It calls attention to tips or supplementary information that is essential for users to refer to.

Quality Certification and Assurance

We certify that series instrument meets all the published specifications at time of shipment from the factory.

Warranty

ITECH warrants that the product will be free from defects in material and workmanship under normal use for a period of one (1) year from the date of delivery (except those described in the Limitation of Warranty below).



Note

Visit <https://www.itechate.com/en/support/register.html> to complete product registration by filling out the necessary information to extend the warranty to two (2) years.

For warranty service or repair, the product must be returned to a service center designated by ITECH.















- The product returned to ITECH for warranty service must be shipped PRE-PAID. And ITECH will pay for return of the product to customer.
- If the product is returned to ITECH for warranty service from overseas, all the freights, duties and other taxes shall be on the account of customer.

Limitation of Warranty

This Warranty will be rendered invalid in case of the following:

- Damage caused by circuit installed by customer or using customer own products or accessories;
- Modified or repaired by customer without authorization;
- Damage caused by circuit installed by customer or not operating our products under designated environment;
- The product model or serial number is altered, deleted, removed or made illegible by customer;
- Damaged as a result of accidents, including but not limited to lightning, moisture, fire, improper use or negligence.

Safety Symbols

	Direct current		ON (power)
	Alternating current		OFF (power)
	Both direct and alternating current		Power-on state
	Chassis (earth ground) symbol.		Power-off state
	Earth (ground) terminal		Reference terminal
	Caution		Positive terminal
	Warning (refer to this manual for specific Warning or Caution information)		Negative terminal
	A chassis terminal	-	-

Safety Precautions

The following safety precautions must be observed during all phases of operation of this instrument. Failure to comply with these precautions or specific warnings elsewhere in this manual will constitute a default under safety standards of design, manufacture and intended use of the instrument. ITECH assumes no liability for the customer's failure to comply with these precautions.

WARNING

- **Do not use the instrument if it is damaged. Before operation, check the casing to see whether it cracks. Do not operate the instrument in the presence of inflammable gasses, vapors or dusts.**
 - **The instrument is provided with a power cord during delivery and should be connected to a socket with a protective earth terminal, a junction box or a three-phase distribution box. Before operation, be sure that the instrument is well grounded.**
 - **Please always use the provided cable to connect the instrument.**
 - **Check all marks on the instrument before connecting the instrument to power supply.**
 - **Ensure the voltage fluctuation of mains supply is less than 10% of the working voltage range in order to reduce risks of fire and electric shock.**
 - **Do not install alternative parts on the instrument or perform any unauthorized modification.**
 - **Do not use the instrument if the detachable cover is removed or loosen.**
 - **To prevent the possibility of accidental injuries, be sure to use the power adapter supplied by the manufacturer only.**
 - **We do not accept responsibility for any direct or indirect financial damage or loss of profit that might occur when using the instrument.**
 - **This instrument is used for industrial purposes, do not apply this product to IT power supply system.**
 - **Never use the instrument with a life-support system or any other equipment subject to safety requirements.**
-

WARNING

- **SHOCK HAZARD Ground the Instrument.** This product is provided with a protective earth terminal. To minimize shock hazard, the instrument must be connected to the AC mains through a grounded power cable, with the ground wire firmly connected to an electrical ground (safety ground) at the power outlet or distribution box. Any interruption of the protective (grounding) conductor or disconnection of the protective earth terminal will cause a potential shock hazard that could result in injury or death.
 - **Before applying power, verify that all safety precautions are taken.** All connections must be made with the instrument turned off, and must be performed by qualified personnel who are aware of the hazards involved. Improper actions can cause fatal injury as well as equipment damage.
 - **SHOCK HAZARD, LETHAL VOLTAGES** This product can output the dangerous voltage that can cause personal injury, and the operator must always be protected from electric shock. Ensure that the output electrodes are either insulated or covered using the safety covers provided, so that no accidental contact with lethal voltages can occur.
 - **Never touch cables or connections immediately after turning off the instrument.** Verify that there is no dangerous voltage on the electrodes or sense terminals before touching them.
 - **After using the device, turn off the power switch of the device before unplugging the power cord or disassembling the terminals.** Do not touch the cable or the terminal immediately. Depending on the model, the dangerous voltage at the plug or terminal is maintained for 10 seconds after the device is switched off. Make sure that there is no dangerous voltage before touching them.
-

CAUTION

- **Failure to use the instrument as directed by the manufacturer may render its protective features void.**
 - **Always clean the casing with a dry cloth. Do not clean the internals.**
 - **Make sure the vent hole is always unblocked.**
-

Environmental Conditions





The instrument is designed for indoor use and an area with low condensation. The table below shows the general environmental requirements for the instrument.

Environmental Conditions	Requirements
Operating temperature	0°C ~ 40°C
Operating humidity	20% ~ 80%(non-condensation)
Storage temperature	-10°C ~ 70 °C
Altitude	Operating up to 2,000 meters
Installation category	II
Pollution degree	Pollution degree 2



Note

In order to ensure the accuracy of measurement, it is recommended to operate the instrument half an hour after start-up.

Regulation Tag

	The CE tag shows that the product complies with the provisions of all relevant European laws (if the year is shown, it indicates that the year when the design is approved).
	The UKCA tag shows that the product complies with the provisions of all relevant United Kingdom laws (if the year is shown, it indicates that the year when the design is approved).
	This instrument complies with the WEEE directive (2002/96/EC) tag requirements. This attached product tag shows that the electrical/electronic product cannot be discarded in household waste.
	This symbol indicates that no danger will happen or toxic substances will not leak or cause damage in normal use within the specified period. The service life of the product is 10 years. The product can be used safely within the environmental protection period; otherwise, the product should be put into the recycling system.

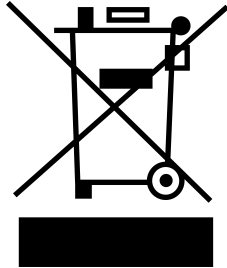
Waste Electrical and Electronic Equipment (WEEE) Directive



Waste electrical and electronic equipment (WEEE) directive, 2002/96/EC

The product complies with tag requirements of the WEEE directive (2002/96/EC). This tag indicates that the electronic equipment cannot be disposed of as ordinary household waste. Product Category

According to the equipment classification in Annex I of the WEEE directive, this instrument belongs to the "Monitoring" product.

If you want to return the unnecessary instrument, please contact the nearest sales office of ITECH.



Compliance Information

Complies with the essential requirements of the following applicable European Directives, and carries the CE marking accordingly:

- Electromagnetic Compatibility (EMC) Directive 2014/30/EU
- Low-Voltage Directive (Safety) 2014/35/EU

Conforms with the following product standards:

EMC Standard

IEC 61326-1 / EN 61326-1 ¹²³

Reference Standards

CISPR 11, Class A

IEC 61000-3-2

IEC 61000-3-3

IEC 61000-4-2

IEC 61000-4-3

IEC 61000-4-4

IEC 61000-4-5

IEC 61000-4-6

IEC 61000-4-11

1. The product is intended for use in non-residential/non-domestic environments. Use of the product in residential/domestic environments may cause electromagnetic interference.
2. Connection of the instrument to a test object may produce radiations beyond the specified limit.
3. Use high-performance shielded interface cable to ensure conformity with the EMC standards listed above.

Safety Standard

IEC 61010-1:2010+A1:2016



Note

This section provides general and universal terms. For more detailed information on the *Declaration of Conformity*, please contact ITECH personnel.

Content

Quality Certification and Assurance	I
Warranty	I
Limitation of Warranty	I
Safety Symbols	II
Safety Precautions.....	II
Environmental Conditions.....	IV
Regulation Tag.....	V
Waste Electrical and Electronic Equipment (WEEE) Directive	VI
 Compliance Information	VII
1 Quick Reference.....	1
1.1 Brief Introduction.....	1
1.2 Front-Panel Overview	2
1.3 Keyboard Introduction.....	3
1.4 Home-Screen Overview.....	4
1.5 Prompt Information Reference.....	5
1.6 Rear-Panel Overview.....	7
1.7 Front Panel Menu Reference.....	8
1.7.1 Configuration Menu Reference	8
1.7.2 System Menu Reference	9
1.7.3 Protect Function Menu Reference.....	14
1.7.4 Advanced Function Menu Reference	16
1.8 Models and Options	16
2 Inspection and Installation.....	20
2.1 Verifying the Shipment.....	20
2.2 Instrument Size Introduction	21
2.3 Rack Mounting	22
2.4 Stacking Instruments	24
2.5 Connecting the Power Cord.....	25
2.6 Connecting the Device Under Test (DUT)	27
2.7 Connect the Communication Interface	30
2.7.1 USB Interface	32
2.7.2 LAN Interface.....	33
2.7.3 CAN Interface	39
2.7.4 GPIB Interface	41
2.7.5 RS-232 Interface	42
2.7.6 RS-485 Interface	44
3 Getting Started	46
3.1 Power-on the Instrument	46
3.2 Set the Output Voltage.....	48
3.3 Set the Output Current.....	48
3.4 Use the Front Panel Menu	48
3.5 Output On/Off Control	49
4 Functions and Features.....	50
4.1 Output Function	50
4.1.1 Set the Output Priority Mode	50
4.1.2 Set the Output-On/Output-Off Delay Time	51
4.1.3 Set the Output Timer Function	51
4.1.4 Output Lock Control.....	52
4.2 System-Related Operations.....	53
4.2.1 Set the Key Beeper.....	53
4.2.2 Set the Power-on State	53
4.2.3 Set the Sense Function State.....	54

4.2.4	Set the Communication Information	54
4.2.5	Set the Bleeder State (Bleeder).....	55
4.2.6	Set the TRIG± Interface Status (Ext IO).....	56
4.2.7	Select Trigger Source(Trig Source).....	56
4.2.8	Restore the Factory Default Settings	57
4.2.9	View the System Information.....	59
4.2.10	Switch Local/Remote Mode.....	60
4.2.11	Key Lock Function	60
4.2.12	Save and Recall Operations.....	61
4.3	Multi-Machine Operation.....	62
4.3.1	Multi-Channel Function	63
4.3.2	Parallel Function (Parallel)	65
4.3.3	Synchronized Function (Link).....	68
4.4	Protection Function	71
4.4.1	Set the Setting Value Limit Protection	71
4.4.2	Set Over-Voltage Protection	72
4.4.3	Set Over-Current Protection	73
4.4.4	Set Over-Power Protection.....	74
4.4.5	Set Under-Voltage Protection.....	75
4.4.6	Set Under-Current Protection.....	76
4.4.7	Over-Temperature Protection.....	77
4.4.8	Set foldback protection	78
4.5	List Function.....	79
4.5.1	Edit List Program	80
4.5.2	Copy List Program.....	82
4.5.3	View List Program.....	82
4.5.4	Run List Program.....	83
4.6	Battery Charging Test Function	84
4.7	External Analog Function (Option).....	85
5	Specification	91
5.1	Main Specification.....	91
5.1.1	IT-M3110.....	91
5.1.2	IT-M3111	93
5.1.3	IT-M3112.....	95
5.1.4	IT-M3113.....	96
5.1.5	IT-M3114	98
5.1.6	IT-M3115.....	100
5.1.7	IT-M3120.....	102
5.1.8	IT-M3121.....	104
5.1.9	IT-M3122.....	106
5.1.10	IT-M3123.....	108
5.1.11	IT-M3124	110
5.1.12	IT-M3125.....	111
5.1.13	IT-M3120S	113
5.1.14	IT-M3112S	115
5.1.15	IT-M3130.....	117
5.1.16	IT-M3131.....	119
5.1.17	IT-M3132.....	121
5.1.18	IT-M3133.....	123
5.1.19	IT-M3134.....	125
5.1.20	IT-M3135.....	127
5.1.21	IT-M3116.....	129
5.1.22	IT-M3126.....	131
5.1.23	IT-M3136.....	133
5.2	Supplemental Characteristics	135
6	Routine Maintenance	136
6.1	Instrument Self-Test.....	136

6.2	Cleaning and Maintenance	136
6.3	Contact of ITECH Engineers	137
6.4	Return for Repair.....	138
A	Appendix	140
A.1	Specifications of Red and Black Test Cables	140

1 Quick Reference

This chapter briefly introduces the front panel, rear panel, keyboard button functions and front panel display functions of this series instrument to ensure a quick understanding of the appearance, structure and key usage features of the instrument before operating the instrument. This chapter does not introduce each operating characteristics in detail. It is just a quick reference guide to help you quickly learn the operating characteristics of the instrument.

- ◆ [Brief Introduction](#)
- ◆ [Front-Panel Overview](#)
- ◆ [Keyboard Introduction](#)
- ◆ [Home-Screen Overview](#)
- ◆ [Prompt Information Reference](#)
- ◆ [Rear-Panel Overview](#)
- ◆ [Front Panel Menu Reference](#)
- ◆ [Models and Options](#)

1.1 Brief Introduction

The IT-M3100 series power supply is a compact, high power density, high performance programmable DC power supply. To increase its mounting efficiency, a thin and lightweight design with 1U height and 1/2 rack width is adopted. The maximum output power is 1500W, the maximum output voltage is 1000V and the maximum output current is 120A. The outputs of voltage and current is limited by the maximum output power. The user can get higher voltage by decreasing the output current or get larger current by decreasing the output voltage. A wide range of voltage and current settings can be obtained by one instrument. In addition, it has parallel operation function (up to 4 units) to expand output current, multi-channel operation function and synchronous operation function (up to 16 units) to meet various development, testing and system needs.

Performance and functions:

- High visible vacuum fluorescent display (VFD)
- High resolution, high accuracy and high stability
- High speed measurement capability
- Intelligent fan control, saving energy and reducing noise
- List function
- Battery charging test function
- Output-on/off delay function to customize test timing

- Parallel operation
- Synchronized operation
- Multichannel operation
- Supporting various optional interfaces: GPIB/ USB/ RS-485/ RS-232/ CAN/ LAN/ External analog interface

1.2 Front-Panel Overview

All of the IT-M3100 series power supplies have the same front panels. The detailed descriptions are shown as below.

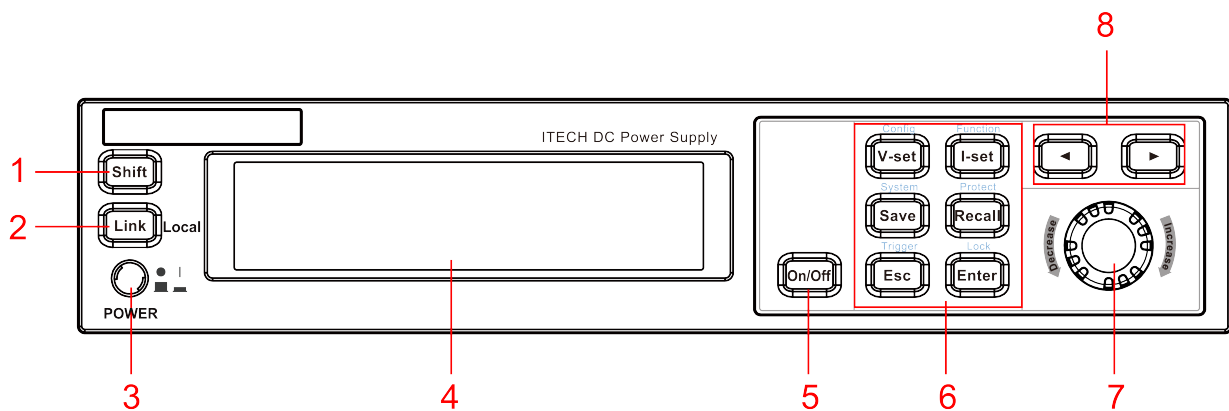

No.	Name	Description
1	[Shift] key	Composite key, combined with other keys to realize functions marked above keys.
2	[Link] (Local) key	<ul style="list-style-type: none"> • Turn the synchronized operation feature on or off. When lit, indicates that the instrument is in the synchronous relationship. • In remote control, press [Shift]+[Link] keys to switch the instrument to local control mode.
3	Power On/Off switch	Turns instrument on or off.
4	Vacuum fluorescent display (VFD)	Displays all instrument functions. The information changes based on selected function.
5	[On/Off] key	Turns the instrument output on or off. When lit, indicates that the output is enabled or on.
6	Function keys group	Refer to 1.3 Keyboard Introduction for the detailed description about the function keys.



No.	Name	Description
7	Push-on knob	<ul style="list-style-type: none"> Rotate the knob to adjust the voltage and current values or scroll pages to view menu items. Rotate the knob clockwise to increase the set value and anticlockwise to decrease the set value. Pushing the knob acts like pressing [Enter] key to confirm an operation.
8	Left, and right arrow keys	Moves the cursor below the setting value or scrolls pages to view menu items.

1.3 Keyboard Introduction

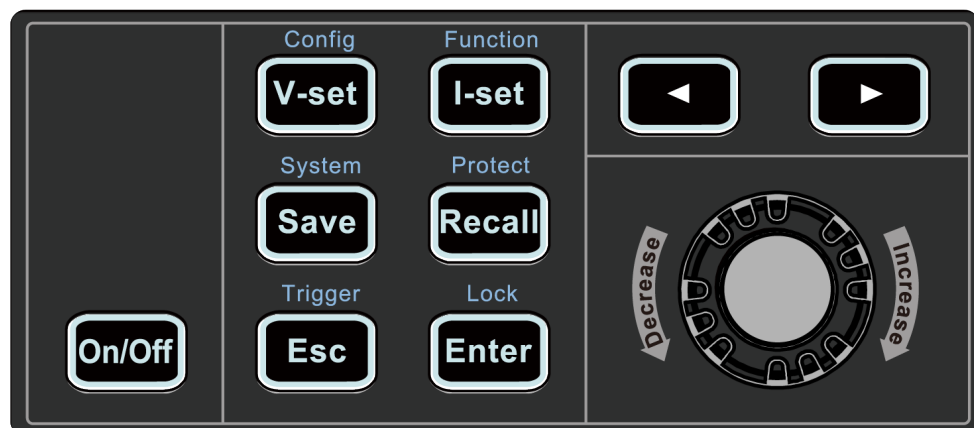
The keyboard introduction of IT-M3100 series power supplies is shown as follows.



Keys	Description
[On/Off]	Turns the instrument output on or off. When lit, indicates that the output is enabled or on.
[V-set]	Sets the output voltage value.
[I-set]	Sets the output current value.
[Save]	Saves the present settings. IT-M3100 power supplies support up to 10 saved setups.
[Recall]	Returns the instrument to the specified setup.
[Esc]	Returns to the previous menu level.

Keys	Description
[Enter]	Selects the menu item or confirm an operation.
 	Moves the cursor below the setting value or scrolls pages to view menu items.

Composite key **[Shift]**, combined with other keys to realize functions marked above keys. The detailed functions are listed as follows.

Keys	Description
[Shift]+[V-set] (Config)	Enter the Config menu.
[Shift]+[I-set] (Function)	Enter the Function menu.
[Shift]+[Save] (System)	Enter the System menu.
[Shift]+[Recall] (Protect)	Enter the Protect menu.
[Shift]+[Link] (Local)	Switch remote control mode to local control mode.
[Shift]+[Esc] (Trigger)	Generate a local trigger signal.
[Shift]+[Enter] (Lock)	Turn the keyboard lock on or off.

1.4 Home-Screen Overview

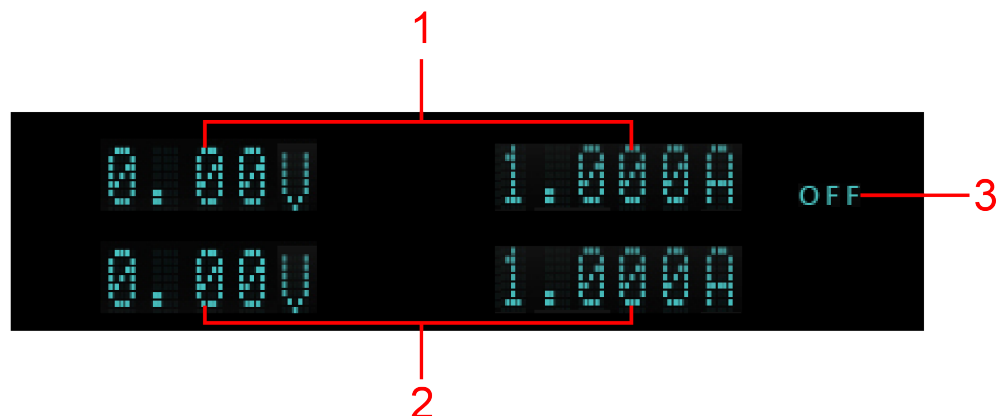

IT-M3100 series power supplies run a self-test automatically when it is turned on. If the self-test finishes with no errors, the screen below is displayed.



No.	Name	Description
1	Output values view area	Displays the present output voltage and current values.
2	Setting values view area	Shows the present setting voltage and current values. You can change these values by pressing the [V-set] and [I-set] keys on the front panel.
3	Output status	Displays the present output status. The power supply always has one of the following status visible: <ul style="list-style-type: none"> • OFF: The output is turned off. • CC: The output is turned on and the power supply is in constant current (CC) mode. • CV: The output is turned on and the power supply is in constant voltage (CV) mode. • : the power supply is in the output-on delay time or output-off delay time.

1.5 Prompt Information Reference

The instrument provides detailed prompt information to help the user learn the function well.

Prompt Information	Description
	Indicates output delay time
	Indicates the key is locked.
	Indicates the instrument is in remote control.
Ri	Indicates the output is self-locked.
System Selftest	Indicates the instrument is running the system selftest.
Switch To Master Mode	Indicates the instrument is switching to the master mode.
Over Current Protect	Indicates the instrument is under over-current protection.

Prompt Information	Description
Over Power Protect	Indicates the instrument is under over-power protection.
Over Voltage Protect	Indicates the instrument is under over-voltage protection.
Under Current Protect	Indicates the instrument is under under-current protection.
Under Voltage Protect	Indicates the instrument is under under-voltage protection.
Sense Protect	Indicates the instrument is under sense abnormal protection.
Over Temp Protect	Indicates the instrument is under over-temperature protection.
Watch Dog Protect	Indicates the instrument is under software watchdog protection.
Undefine Prot	Indicates the undefined protection happens.
The Key Is Locked!	Indicates the key is locked.
Remote Mode!	Indicates the instrument is in remote control mode.
RWT Mode!	Indicates the instrument is in remote control mode and pressing the LOCAL button does not switch the instrument to local control mode.
Save Successful	Indicates the save operation is successful.
Save Failed	Indicates the save operation fails.
File is empty!	Indicates the recalled file is empty.
Waiting for Trigger	Indicates the list program is waiting for trigger.
Input Cal Code To Start:	Indicates the user needs to input the calibration code
Cal Is Initing...	Indicates the calibration operation is initializing.
Calibration Finished!	Indicates the calibration operation is finished.

1.6 Rear-Panel Overview

The detailed descriptions of the IT-M3100 series power supplies are shown as below.

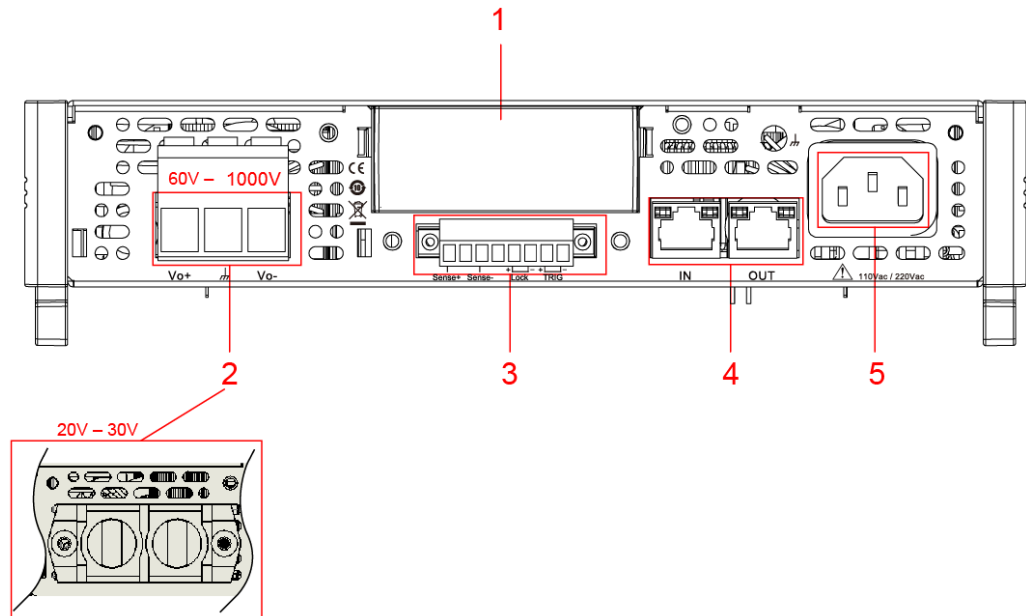

Note

For the IT-M3120S model, the instrument has been shipped with the IT-E1206 (USB and LAN interfaces) inserted into the corresponding position on the rear panel.

No.	Name	Description
1	Optional expansion slot	Optional interfaces: (Plastic plugs are inserted by default when the user does not purchase the interface.) <ul style="list-style-type: none"> IT-E1205: GPIB interface IT-E1206: USB and LAN interfaces (Only IT-M3120S model comes standard with this communication box) IT-E1207: RS-232 and CAN interfaces IT-E1208: Analog interface and RS-485 IT-E1209: USB interface
2	DC output terminals	Used to connect DUT. <ul style="list-style-type: none"> Pluggable terminals for 60V to 1000V models. Electrode terminals for 20V to 30V models.

No.	Name	Description
3	<ul style="list-style-type: none"> Remote sense terminals (Sense \pm) Output lock terminals (Lock\pm) Trigger signal terminals (TRIG\pm) 	The descriptions of each terminals are as follows. <ul style="list-style-type: none"> Remote sense terminals, used for maximizing measurement accuracy. Output lock terminals, short Lock+ and Lock– terminals to disable the output function of the power supply. Trigger signal terminals, when set to In, the terminals can receive high level pulse signal as a trigger source; when set to Out, if the trigger happens, the terminals can generate high level pulse signal.
4	System bus interfaces (IN OUT)	Used for communication between instruments in parallel operation, multichannel operation and synchronized operation features.
5	AC power input socket	Used to connect AC power to start instrument, supports 110 V or 220 V.

1.7 Front Panel Menu Reference

This section lists the maps of all front panel menu, including Config menu, System menu, Protect menu and Function menu. For a brief tutorial, refer to [3.4 Use the Front Panel Menu](#).

1.7.1 Configuration Menu Reference

Press **[Shift]+[V-set]** (Config) to enter into the configuration menu interface.

Config	Configuration menu		
	P-Set	Only supported by IT-M3130/IT-M3131/IT-M3132/IT-M3133/IT-M3134/IT-M3135/IT-M3116/IT-M3126/IT-M3136 models. Set the power value for the CW (constant power) mode.	
	Mode	Set the output priority mode	
		CV priority	Voltage priority mode
		CC priority	Current priority mode
	V-Rise Time	Voltage rising time	When select CV priority, the menu shows the two items
	V-Fall Time	Voltage falling time	
	I-Rise Time	Current rising time	When select CC priority, the menu shows the two items
	I-Fall Time	Current falling time	

	On Delay	Set the output-on delay time		
	Off Delay	Set the output-off delay time		
	Timer	Set the output timer function		
		Off	Turn the output timer off	
		On	Turn the output timer on	
		Time	Set the output time	

1.7.2 System Menu Reference

Press **[Shift]+[Save]** (System) to enter into the configuration menu interface.

System	System Menu			
	Beep	Set the key beeper state.		
		Off	Turn the key beeper off.	
		On	Turn the key beeper on.	
	PowerOn	Select the power-on state.		
		Reset	When the power supply is powered on, the power supply will initialize some settings and output state.	
		Last	When the power supply is powered on, the power supply will remain the same settings and output state as last time you turned off the power supply.	
		Last+Off	When the power supply is powered on, the power supply will remain the same settings as last time you turned off the power supply, but the output state is OFF state.	
	Sense	Set the sense function state.		
		Off	Turn the sense function off.	
		On	Turn the sense function on.	
	Comm	Set the communication information between instrument and PC. (The menu displays different interfaces information automatically based on the inserted communication board.)		
		None	No optional communication interfaces.	
		GPIB	When insert IT-E1205 communication board into expansion slot, the menu displays this information.	
			General purpose interface bus (GPIB) communication interface. Set the communication address within the range from 0 to 30.	
		USB+LAN	When insert IT-E1206 communication board into expansion slot, the menu displays this information.	

			USB	Universal serial bus (USB) communication interface. (When insert IT-E1209 communication board into expansion slot, the menu displays this information.)
			TMC	USB-TMC protocol
			VCP	Virtual serial port
			LAN	LAN communication interface.
			Lan Info	View the LAN information.
				<ul style="list-style-type: none"> • Status • IP Mode Status • IP Addr • Sub Net • Gateway • DNS1 (Primary address) • DNS2 (Secondary address) • MAC Addr • Host Name • Host Desc • Domain • TCPIP INSTR • Socket Port
			Lan Config	Configure LAN information.
			IP Mode	Set IP mode.
				Auto: automatically configure the address of the instrument. Manual: manually configure the address of the instrument by entering values in the following six fields. The following information only appear when Manual is selected. <ul style="list-style-type: none"> • IP Addr • Sub Net • Gateway • DNS1 (Primary address)

					<ul style="list-style-type: none"> • DNS2 (Secondary address) • Socket Port
				Lan Restore	Select whether to reset the LAN to the default settings or not.
					<ul style="list-style-type: none"> • NO • YES
				Lan Save	Select whether to save the LAN setting or not.
					<ul style="list-style-type: none"> • NO • YES
		RS232 +CAN	When insert IT-E1207 communication board into expansion slot, the menu displays this information.		
			RS232	RS232 communication interface.	
				Display as the following format: baud rate_data bit_parity bit_stop bit. <ul style="list-style-type: none"> • Select the baud rate from the following options: 4800, 9600, 19200, 38400, 57600, 115200 • The data bit, parity bit and stop bit are fixed: 8_None_1 	
			CAN	CAN communication interface.	
				Select the baud rate from the following options: 20k, 40k, 50k, 80k, 100k, 125k, 150k, 200k, 250k, 400k, 500k, 1000k.	
				Set the instrument address to a number from 1 to 127.	
		Ext +RS485	When insert IT-E1208 communication board into expansion slot, the menu displays this information.		
			Protocol	Sets the protocol type of the RS485 communication interface: <ul style="list-style-type: none"> • SCPI: Defaults to SCPI-formatted protocol. • Modbus: Uses the Modbus RTU protocol format. Firmware version V1.63 and above are supported.	
			Ext-Program	Set external analog interface state. (External analog interface is optional.)	
				Off	Turn the external analog function off.
				On	Turn the external analog function on.

		RS485	RS485 communication interface parameter setting.
			Display as the following format: baud rate_data bit_parity bit_stop bit. <ul style="list-style-type: none"> Select the baud rate from the following options: 4800, 9600, 19200, 38400, 57600, 115200. The data bit, parity bit and stop bit are fixed: 8_None_1.
		RS485 Addr	RS485 communication address. Setting range: 0~127.
	SCPI	The unit for setting the voltage or current slope: <ul style="list-style-type: none"> Default: The default value, indicating the slope unit is in milliseconds (ms). Extended: The extended option, indicating the slope unit is in volts per millisecond (V/ms) or amperes per millisecond (A/ms). 	
	Parallel	Set the instruments to parallel operation mode.	
		Single	Set the instrument to single mode, i.e., disable the parallel operation mode.
		Slave	Set the instrument to slave mode.
		Slave group	Specify the Master group associated with this slave.
		Master	Set the instrument to master mode.
		Master group	Specify the master group within the range from A to H.
		Master Total	Set the total instrument number of the same group within the range from 1 to 4. When set to 1, the instrument mode is single mode.
	Link	Set the instruments to synchronized operation mode.	
		Status	Set the synchronized state. Same function as the [Link] key.
		Offline	Disable the Link function.
		Online	Enable the Link function.
		Mode	Set the synchronized mode.
		On/Off Only	Set multiple units to output on/off and Save/Recall synchronization.
		Track	Set multiple units to output on/off, Save/Recall synchronization and voltage proportional changing.
		Reference	Set the voltage proportional relationship among multiple units.

		Duplicate	Set multiple units to output on/off synchronization, voltage/current setting value changing synchronization, Save/Recall synchronization, priority mode synchronization, voltage/current rising/falling synchronization and Protect menu function synchronization.
Chan Number	Set the channel number.		
Bleeder	Set the Bleeder circuit state (When using the battery charging test function, the user need to turn the Bleeder circuit off)		
	On	Turn the Bleeder circuit on.	
	Off	Turn the Bleeder circuit off.	
Ext IO	Set the rear panel interface TRIG± receiving and transmitting status, and control the trigger input/output signal of the instrument		
	Trig Out	When the trigger source is set to Keypad or Bus and the trigger happens, the TRIG± interface generates a high pulse trigger signal.	
	Trig In	When the trigger source is set to Ext , inputting a 0V low-level signal (or short-circuiting the TRIG± pins) can generate a trigger.	
	On Sync Out	As the indication signal of the instrument output status. When the output is OFF, the pins output 0V low level; when the output is ON, the pins output 5V high level.	
	On Sync In	Used to control the output state of the instrument. Input 0V low level to the pins, the instrument output is OFF; input 5V high level to the pins, the instrument output is ON.	
Trig Source	Set the trigger source		
	Keypad	Keypad trigger, [Shift]+[Esc] (Trigger)	
	Bus	Remote interface trigger command, like *TRG	
	Ext	External trigger, when the TRIG± interface state is set to IN and receive a high pulse signal, the instrument generates trigger.	
Lock Port	Set the working mode and control level of the output disable port.		
	Mode	Set the operation mode for the output disable (Inhibit) port: <ul style="list-style-type: none"> • Off: Disables the Inhibit function. • Living: Output is controlled by the living follow mode. • Latch: Output is controlled by the latch mode. For detailed instructions, refer to the 4.1.4 Output Lock Control .	
	Polar	Set the control level for the output disable port.	

		<ul style="list-style-type: none"> Normal (Default): When Lock+ and Lock- are short-circuited, the control port input is True; if open-circuited, then it is False. Inverse: When Lock+ and Lock- are short-circuited, the control port input is False; if open-circuited, then it is True. For detailed instructions, refer to the 4.1.4 Output Lock Control .
	System Reset	Select whether to restore the factory default settings or not.
		NO Don't restore the factory default settings.
		YES Restore the factory default settings.
	System Info	View the system information.
		Model Display the instrument model.
		ArmVer Display the control board version.
		CommVer Display the communication board version.
		DSPVer DSP Version Only displayed for models IT-M3130/IT-M3131/IT-M3132/IT-M3133/IT-M3134/IT-M3135/IT-M3116/IT-M3126/IT-M3136.
		SN Display the serial number.
		Last Cal Display last calibration date.
		Run Time Display the instrument running time.

1.7.3 Protect Function Menu Reference

Press **[Shift]+[Recall]** (Protect) to enter into the configuration menu interface.

Protect	Protection function menu	
	U-Max	The maximum output voltage setting value.
	U-Min	The minimum output voltage setting value
	P-Max	The maximum output power value Only supported for IT-M3110/IT-M3111/IT-M3112/IT-M3113/IT-M3114/IT-M3115/IT-M3120/IT-M3121/IT-M3122/IT-M3123/IT-M3124/IT-M3125/IT-M3120S/IT-M3112S models.
	OVP	Over-voltage protection.
		Off Turn the OVP function off.
		On Turn the OVP function on.
		Level Over-voltage limit.

		Delay	Delay time.
OCP	Over-current protection.		
	Off	Turn the OCP function off.	
	On	Turn the OCP function off.	
		Level	Over-current limit.
		Delay	Delay time.
OPP	Over-power protection.		
	Off	Turn the OPP function off.	
	On	Turn the OPP function on.	
		Level	Over-power limit.
		Delay	Delay time.
UVP	Under-voltage protection.		
	Off	Turn the UVP function off.	
	On	Turn the UVP function on.	
		Level	Under-voltage limit.
		Delay	Delay time.
		Warm up	Warm-up time.
UCP	Under-current protection.		
	Off	Turn the UCP function off.	
	On	Turn the UCP function on.	
		Level	Under-current limit.
		Delay	Delay time.
		Warm up	Warm-up time.
FOLDBACK	Set foldback function		
	Off	Turn off the FOLDBACK function	
	CC	Foldback protection is triggered when the power loop is switched to CC.	
		Delay	Delay time.
	CV	Foldback protection is triggered when the power loop is switched to CV.	
		Delay	Delay time.

1.7.4 Advanced Function Menu Reference

Press **[Shift]+[I-set]** (Function) to enter into the function menu interface.

The main functions of function menu are listed in the table below. Please refer to the corresponding sections for the detailed information about each function.

Function	Function menu	
	List	4.5 List Function
	Battery	4.6 Battery Charging Test Function

1.8 Models and Options

IT-M3100 series models

Model	Voltage (V)	Current (A)	Power (W)
IT-M3110	20V	100A	400W
IT-M3120	20V	100A	850W
IT-M3111	30V	70A	400W
IT-M3121	30V	70A	850W
IT-M3112	80V	22A	400W
IT-M3122	80V	22A	850W
IT-M3113	150V	12A	400W
IT-M3123	150V	12A	850W
IT-M3114	300V	6A	400W
IT-M3124	300V	6A	850W
IT-M3115	600V	3A	400W
IT-M3125	600V	3A	850W
IT-M3120S	60V	35A	800W
IT-M3112S	60V	20A	200W
IT-M3130	20V	120A	1500W
IT-M3131	30V	100A	1500W
IT-M3132	80V	40A	1500W

Model	Voltage (V)	Current (A)	Power (W)
IT-M3133	150V	20A	1500W
IT-M3134	300V	10A	1500W
IT-M3135	600V	5A	1500W
IT-M3116	1000V	3A	400W
IT-M3126	1000V	3A	850W
IT-M3136	1000V	3A	1500W

Options

You can purchase accessories for this series of instruments separately, including the following:

- **Scalable interface**

The interface expansion slot provided on the rear panel of the instrument allows users to flexibly expand according to their needs. Different interface cards can be selected to achieve different functions. Includes communication interface or external analog interface.

- **Cabinet installation**

This series instruments can be mounted on a standard 19-inch cabinet. ITECH has prepared a special bracket for the user as a mounting kit.

The detailed descriptions of the options are as follows.



Note

The following optional accessories from ITECH are sold separately. Users need to purchase separately.

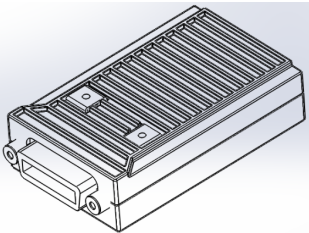
Device Name	Model	Description	Type
GPIB communication interface 	IT-E1205	When the user needs to use GPIB interface to enable remote operation, this option is the right choice.	Optional
USB / LAN communication interface	IT-E1206	When the user needs to use USB or LAN interface to enable	Optional

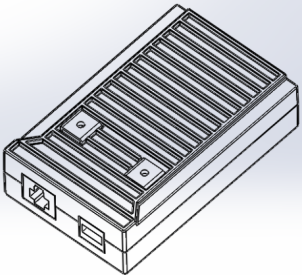
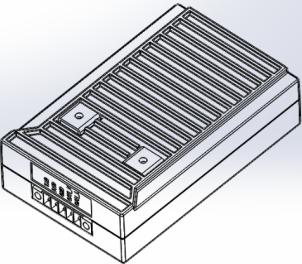
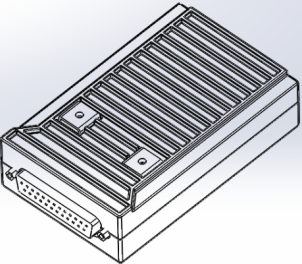
Device Name	Model	Description	Type
		remote operation, this option is the right choice. (Only IT-M3120S model comes standard with this communication box)	
RS-232 / CAN communication interface 	IT-E1207	When the user needs to use RS-232 or CAN interface to enable remote operation, this option is the right choice.	Optional
External analog / RS485 communication interface 	IT-E1208	When the user needs to use RS-485 to enable remote operation or external analog function, this option is the right choice.	Optional

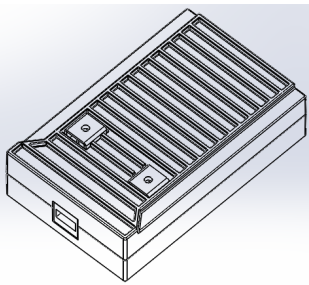
Device Name	Model	Description	Type
USB communication interface 	IT-E1209	When the user needs to use USB interface to enable remote operation, this option is the right choice.	Optional
Cabinet installation kit	IT-E154 Series	When the instrument needs to be installed in cabinet, this kit is needed. Please refer to <i>«IT-E154 User Manual»</i> for detailed description about the installation method.	Optional

WARNING

It is strictly forbidden to directly insert and remove the communication card when the instrument is powered. Power off the instrument before installing the communication card. After the communication card is installed, power on the instrument. At this time, the instrument takes about 30 seconds to update the communication board automatically.

2 Inspection and Installation

- ◆ Verifying the Shipment
- ◆ Instrument Size Introduction
- ◆ Rack Mounting
- ◆ Stacking Instruments
- ◆ Connecting the Power Cord
- ◆ Connecting the Device Under Test (DUT)
- ◆ Connect the Communication Interface

2.1 Verifying the Shipment

Unpack the box and check the contents before operating the instrument. If wrong items have been delivered, if items are missing, or if there is a defect with the appearance of the items, contact the dealer from which you purchased the instrument immediately.

The package contents include:

Item	Qty.	Model	Remarks
Programmable DC Power Supply	X 1	IT-M3100 series	Please refer to 1.8 Models and Options for the detailed models.
Power Cord	X 1	-	User may select an appropriate power cord that matches the specifications of power socket used in the area. See the Section 2.5 Connecting the Power Cord for details.
Multiple instruments connection cables	X 1	IT-E251	When the user needs to connect the System Bus interfaces between Multiple instruments in parallel operation, multichannel operation and synchronized operation features, this cable is the right choice.
Calibration Certificate	X 1	-	It is the calibration certificate of the instrument before delivery.

Note

Upon verification of the shipment, keep the package and relevant contents thereof in a safe place. When returning the instrument for warranty service or repair, the specified packing requirements shall be met.

2.2 Instrument Size Introduction

The instrument should be installed at well-ventilated and rational-sized space. Please select appropriate space for installation based on the power supply size.

The detailed sizes are shown as below.

IT-M3110/IT-M3111/IT-M3120/IT-M3121/IT-M3130/IT-M3131

Without protective cover:

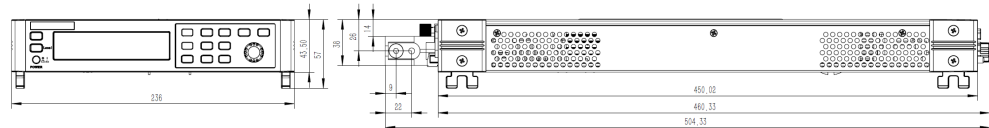

With protective cover:

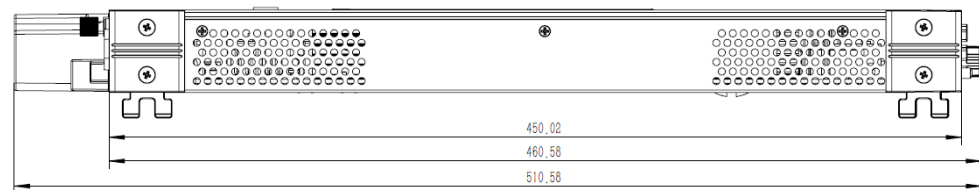

IT-M3112/IT-M3113/ITM3114/ IT-M3115/IT-M3122/ IT-M3123/IT-M3124/IT-M3125/IT-M3120S/IT-M3112S/IT-M3132/IT-M3133/IT-M3134/IT-M3135/IT-M3116/IT-M3126/IT-M3136

Without protective cover:

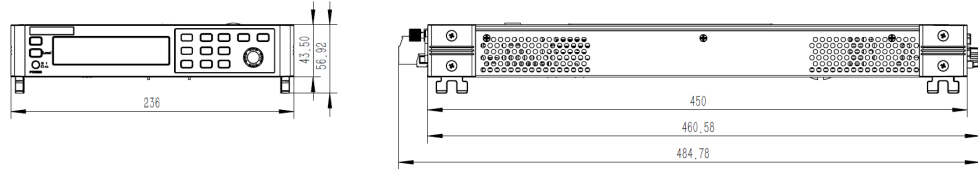

With protective cover:

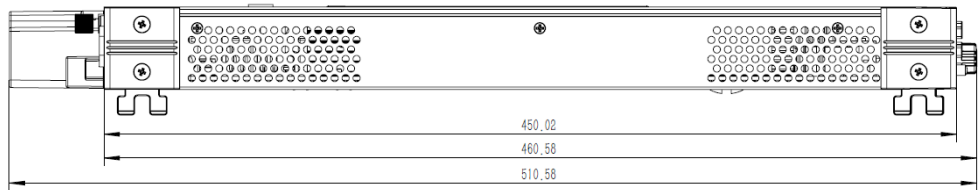

2.3 Rack Mounting

This instrument can be installed on standard 19-inch rack. ITECH provides user with optional mount kit IT-E154. The detailed operation please refer to the **IT-E154 User Manual** of your mount kit.

WARNING

When installing the device in a rack, do not block the ventilation holes of the instrument and reserve appropriate air ducts to maximize heat dissipation.

The ventilation hole locations for this series of instruments are shown in the figure below.



Note

The actual positions of the terminals on the rear panel are subject to the device. The diagram below is used only to demonstrate the function of the ventilation holes.



To ensure the best thermal performance of the instrument, refer to the following precautions before installing it into the cabinet:

1. 400W models (IT-M3112, IT-M3113, IT-M3114, IT-M3115) do not require the addition of a space between two adjacent layers.

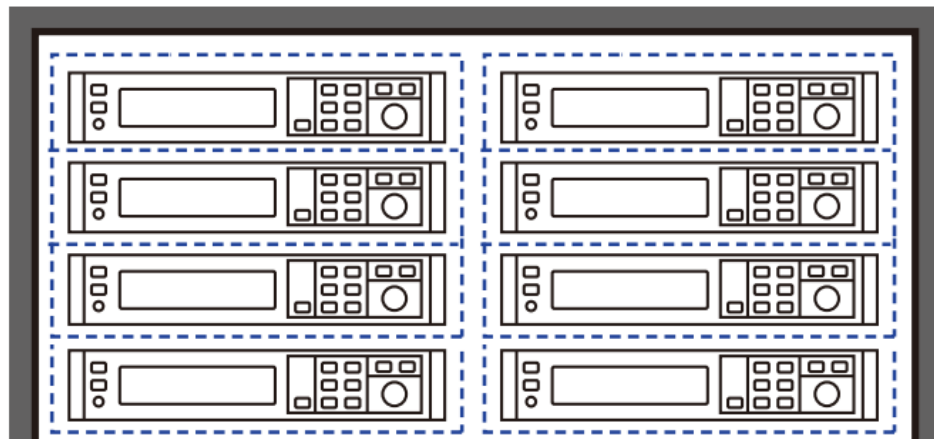

2. The 400W models (IT-M3110, IT-M3111, IT-M3116) need to be fitted 2U height (two layers) and 1U empty (one layer) for installation into the cabinet.

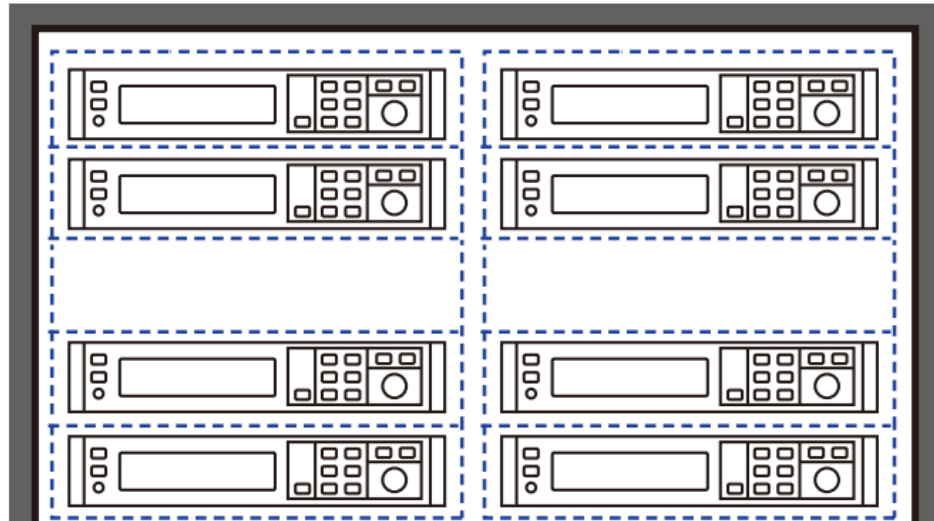

- All 850W and 1500W models need to be fitted with 2U height (two layers) and 1U empty (one layer).

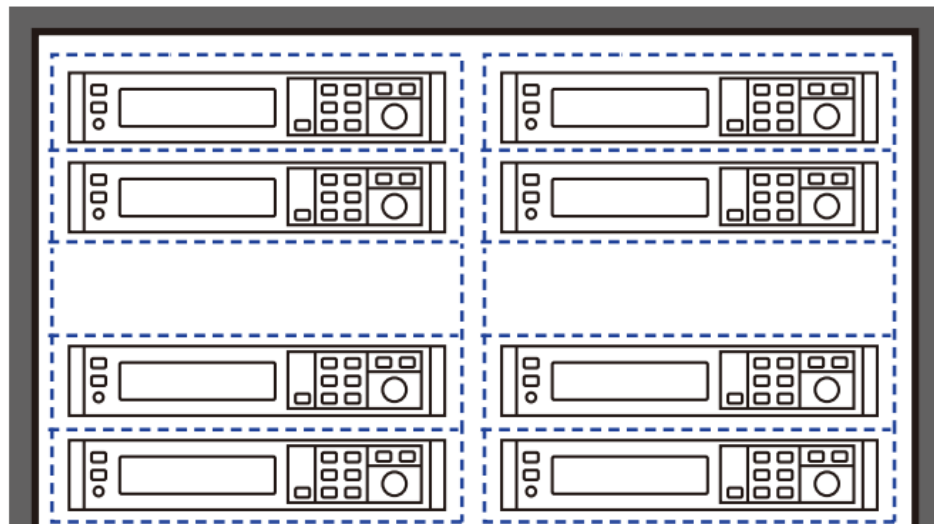

2.4 Stacking Instruments

This series power supply adopts patented appearance design with a side ventilation structure. Thanks to the flexible modular architecture, the instruments can be directly and easily stacked on the desk without purchasing any accessories. A maximum of 10 instruments can be stacked. The stacking schematic diagram is as shown below.

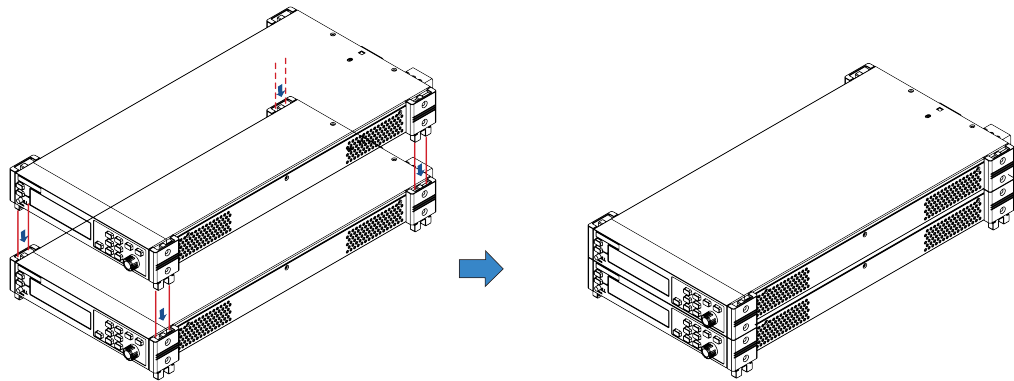

2.5 Connecting the Power Cord

Precautions

To prevent electric shock and damage to the instrument, observe the following precautions.

WARNING

- **The power cords supplied with this product is certified for safety. In case the supplied lines assembly needs to be replaced, or an extension lines must be added, be sure that it can meet the required power ratings of this product. Any misuse voids the warranty of this product.**
- **Before connecting power cord, be sure to confirm that the power voltage matches with the supply voltage.**
- **Before connecting power cord, be sure to switch off the instrument. Power switch is in Off position.**
- **To avoid fire or electric shock, make sure to use the power cord supplied by ITECH.**
- **Do not use an extended power cord without protective grounding, otherwise the protection function will fail.**
- **Be sure to connect the main power socket to the power outlet with protective grounding. Do not use terminal board without protective grounding.**

Categories of Power Cords

The standard power cord types are as follows. Please select appropriate power cords appropriate to local voltage based on the specifications of power cords below. If purchased model fails to meet local voltage requirements, please contact distributor or factory for change.

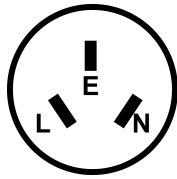

China
IT-E171

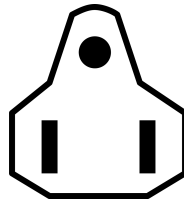

United States &
Canada & Japan
IT-E172

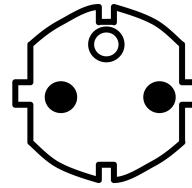

Europe
IT-E173

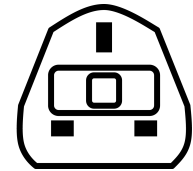

England
IT-E174

AC Power Input Level

IT-M3100 power supplies operate at the following AC power input.

- **Voltage 1:** 176V to 264V, 47 to 63 Hz
- **Voltage 2:** 99V to 121V, 47 to 63 Hz

CAUTION

- When the AC input of the models (IT-M3120/IT-M3121/IT-M3122/IT-M3123/IT-M3124/IT-M3125/IT-M3120S) is Voltage 2, the output power is limited to 600W. If the user wants to use full power output, please use Voltage 1 as the AC input.
- When the AC input of the models (IT-M3130/IT-M3131/IT-M3132/IT-M3133/IT-M3134/IT-M3135/IT-M3126/IT-M3136) is Voltage 2, the output power is limited to 750W. If the user wants to use full power output, please use Voltage 1 as the AC input.

For more information, please refer to the specifications of the corresponding model.

Connecting the Power Cord

To connect the power cord:

1. Make sure that the front-panel power switch is in the OFF position.
2. Connect the female end of the supplied line cord to the AC receptacle on the rear panel.
3. Connect the plug of the power cord to a grounded AC outlet.

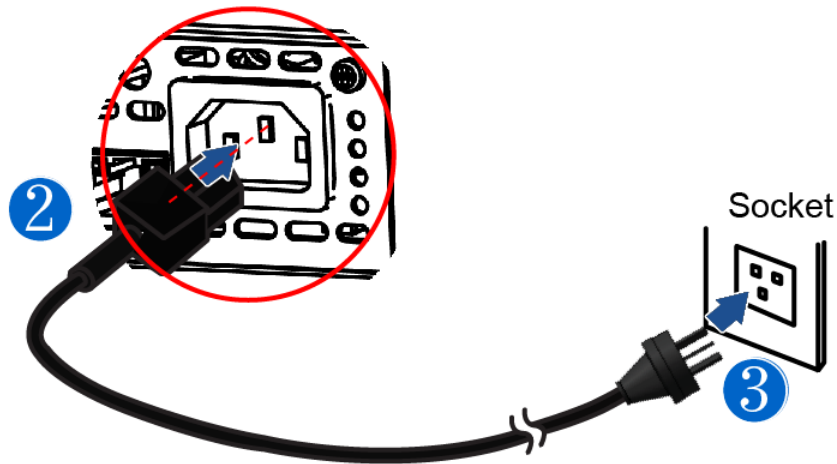

2.6 Connecting the Device Under Test (DUT)

The instrument supports two connection methods between power supply and DUT: Local measurement and Remote sensing. This series power supplies include built-in circuit that connect or disconnect the \pm sense terminals from their corresponding \pm output terminals. As shipped, the sense terminals are internally connected to the output terminals. This is referred to as Local measurement. If you need to use remote sensing, after making the connection, be sure to turn the sense function on. Please refer to [4.2.3 Set the Sense Function State](#) for the detailed operations.

Precautions

To prevent electric shock and damage to the instrument, observe the following precautions.

WARNING

- **Before connecting test cables, be sure to switch off the power supply. Power switch is in Off position, otherwise touching the output terminals on the rear panel may result in personal injury or death due to electric shock.**
- **To avoid electrical shock, before testing, please make sure the rating values of the testing cables, and do not measure the current that higher than the rating value. All test cables shall be capable of withstanding the maximum short circuit output current of the power supply without causing overheat.**
- **If several loads are provided, each pair of load wires shall safely withstand the rated short circuit output current of the power supply under full load.**
- **To avoid battery short circuit, be sure to check that the test line end is not connected when connecting or disassembling the test line. When the test line end is connected with battery, short circuit may cause severe accident.**
- **Please check that the test cables can withstand maximum current.**
- **During wiring, check that the anode and cathode of the test lines are properly and tightly connected; anode ON and cathode OFF are prohibited.**
- **Always ensure the protective covers for the DC output and Sense terminals are correctly installed.**
- **If you need to pull out the green output terminal, please lift it up and pull it out, otherwise it will damage the instrument.**

Specification

Test cables are not standard accessories for the instrument. Please select optional red and black test cables for individual sales based on the maximum current value. For specifications of test cables and maximum current values, refer to [A.1 Appendix→Specifications of Red and Black Test Lines](#) for more information.

Local Measurement

The connection diagram and steps of local sensing are as follows, taking the pluggable output terminals as an example.

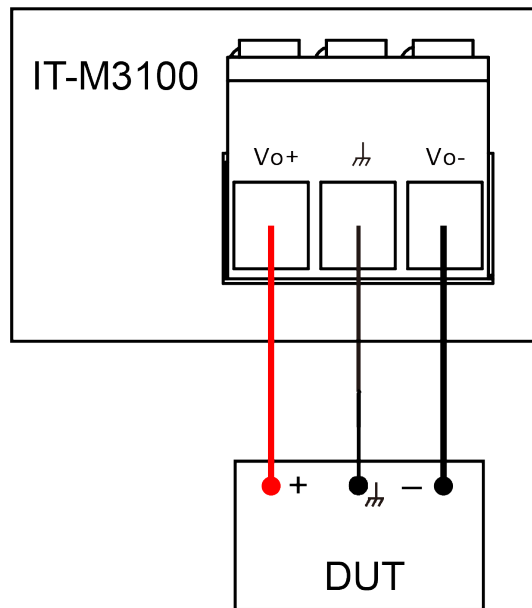

1. Remove the output terminal cover.
2. Loosen the screws of the output terminals and connect the red and black test cables to the output terminals, and connect the ground terminal correctly. Re-tighten the screws.

When maximum current that one test cable can withstand fails to meet the current rated current, use multiple pieces of red and black test cables. For example, the maximum current is 1,200 A, then 4 pieces of 360 A red and black cables are required.

3. Thread the test cables through the output terminals cover and install the cover.
4. Connect the other end of the red and black cables to the DUT. The positive and negative poles must be properly connected and fastened when wiring.

Remote Sensing

When the DUT consumes large current or the wires are too long, there is a voltage drop on the wires between the DUT and output terminal of the power supply. To maximize measurement accuracy, you can use remote sense wire connections to monitor and improve the voltage adjustment on the DUT and compensate for the voltage drop on the wires .

When the power supply is used for measuring battery charge in actual applications, the voltage drop of the wire will lead to voltage inconsistency of both ends and inconsistency of the cutoff voltage of power supply and the actual voltage of battery, resulting in inaccurate measurement.

The connection diagram and steps of remote sensing are as follows, taking the pluggable output terminals as an example.

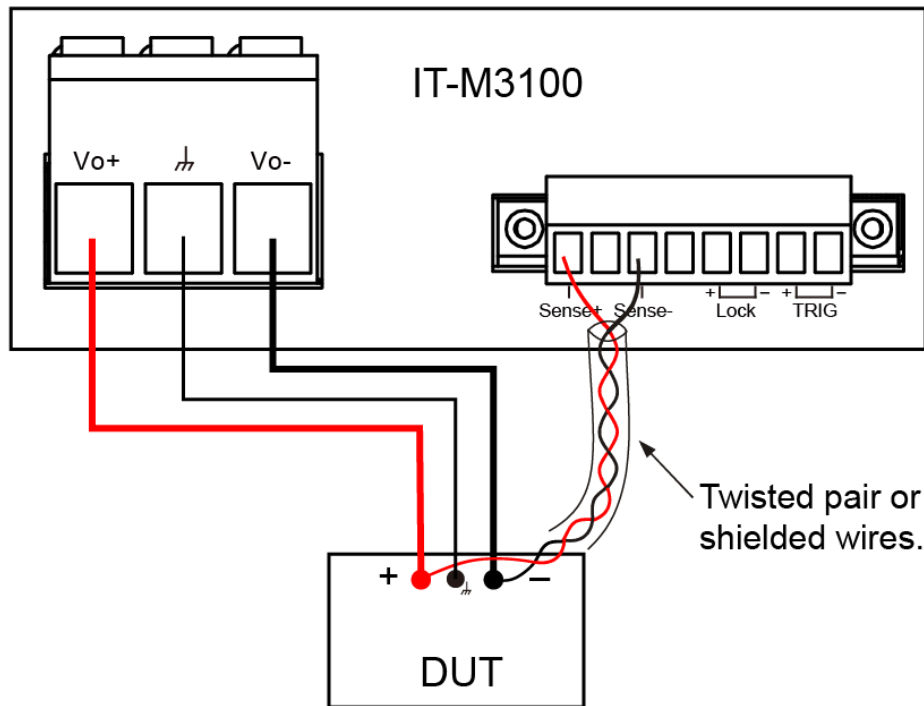
Note

To ensure the stability of the system, use armored twisted-pair cables between the remote sense terminals and the equipment under test.

1. Remove the output terminal cover.
2. Loosen the screws of the output terminals and connect the red and black test cables to the output terminals, and connect the ground terminal correctly. Re-tighten the screws.

When maximum current that one test cable can withstand fails to meet the current rated current, use multiple pieces of red and black test cables. For example, the maximum current is 1,200 A, then 4 pieces of 360 A red and black cables are required.
3. Refer to the wiring diagram, and use armored twisted-pair cables to connect the remote sense terminals and the equipment under test.
4. Thread the red and black test cables and sense cables through the output terminals cover and install the cover.
5. Connect the other end of the remote sense cables and the red and black cables to the DUT. The positive and negative poles must be properly connected and fastened when wiring.
6. Power on the instrument and turn the sense function on. Please refer to [4.2.3 Set the Sense Function State](#) for the detailed operations.

2.7 Connect the Communication Interface

This series power supply has no standard-equipped communication interfaces. Users can purchase communication cards separately. Users can choose one of

RS-232, USB, GPIB, RS-485, LAN, CAN to communicate with the computer. For details, see [1.8 Models and Options](#).

The reserved communication card installation slot is on the rear panel of the instrument. Users can install it after purchasing the communication card.

CAUTION

- **It is strictly forbidden to directly insert and remove the communication card when the instrument is powered. Power off the instrument before installing the communication card. After the communication card is installed, power on the instrument. At this time, the instrument takes about 30 seconds to update the communication board automatically.**
- **Always follow the ESD rules to insert the interface card into the slot.**
- **Except the communication card, do not insert other hardware to this slot.**
- **If no communication card is used, it is recommended to install the plastic plug to prevent the interior from getting dirty, and to avoid the change of air circulation direction.**

The installing steps for the purchased communication card are as follows:

1. Power off the instrument.
2. Remove the plug of the rear panel interface.
 - a. Use a small flat screwdriver to press the clip at the upper cover opening.
 - b. At the same time, use another small flat screwdriver to stir the slots one by one from another opening of the upper cover, and push the plastic plug out.

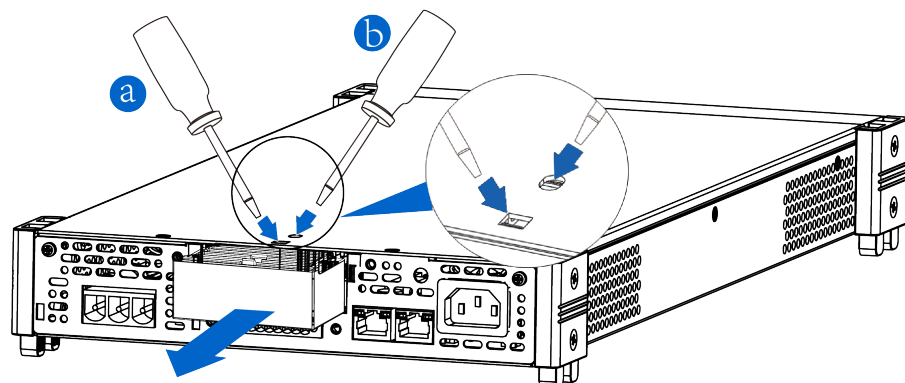

3. Install the purchased communication card.
 - a. Use a screwdriver to unscrew the screws above the communication card.
 - b. Push the communication card into the instrument slot.

- c. Use the screwdriver and screws to lock the instrument and the communication card.
4. After the communication card is installed successfully, power on the instrument.

2.7.1 USB Interface

When the optional interface card is a stand-alone USB interface (IT-E1209) or USB+LAN interface (IT-E1206), the following can help users quickly understand the steps required to connect the USB interface. The figure below shows a typical USB interface system.

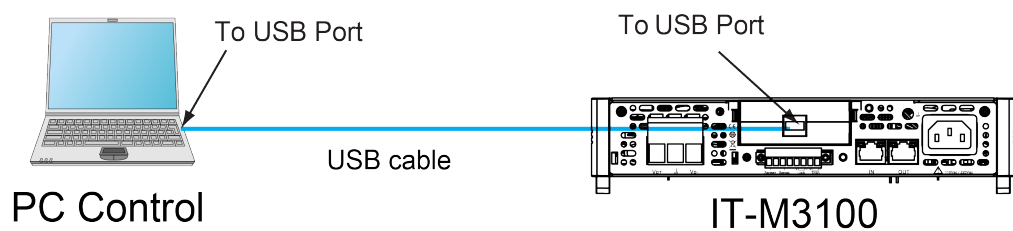

Note

- Take the IT-E1209 communication card box as an example. If you install IT-E1206, please refer to the actual interface position.
- The rear panel shown in the figure is only an example. The actual appearance of the rear panel is subject to the specific instrument.

The operation steps to use the USB interface are as follows.

1. Refer to the USB connection diagram, Connect the power supply and the computer using a cable with two USB interfaces (each end).
2. Select the USB interface type in the system menu.
 - a. Press **[Shift]+[Save]** (System) to enter into the system menu interface.
 - b. Use left and right keys or rotate the knob to select **Comm** and press **[Enter]** key to confirm.
 - c. Use left and right keys or rotate the knob to select **USB** and press **[Enter]** key to confirm.
 - d. Rotate the knob to select the desired interface type and press **[Enter]** key to confirm.
 - **TMC**: USB_TMC interface;
 - **VCP**: virtual serial port. Select this type, you need to install the corresponding driver (download from the ITECH website or contact ITECH

agent). The device manager of PC will display 'Prolific USB-to-Serial COM Port' after installing.

- e. After finishing the setting, press **[Esc]** to exit.

2.7.2 LAN Interface

When the user's optional interface card is a LAN+USB interface (IT-E1206), the following is required to use the LAN interface.

LAN Connection

Use the following steps to quickly connect your instrument to your LAN and configure it. Two typical LAN interface systems are described below: private LAN and site LAN.

- **Connect to the private LAN**

A private LAN is a network in which LAN-enabled instruments and computers are directly connected. They are typically small, with no centrally managed resources. When connected to a computer, a direct attached network cable can be used to connect directly to the computer via the LAN interface.

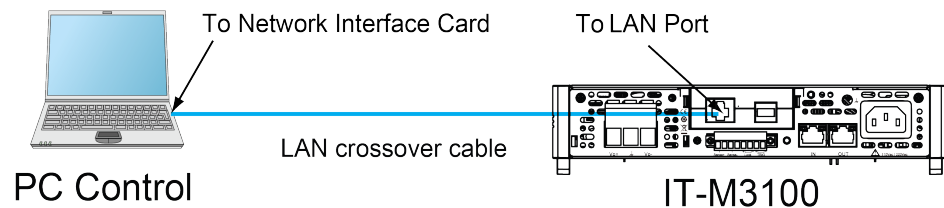

- **Connect to the site LAN**

A site LAN is a local area network in which LAN-enabled instruments and computers are connected to the network through routers, hubs, and/or switches. They are typically large, centrally-managed networks with services such as DHCP and DNS servers. When connected to a computer, a direct attached network cable can be used to connect to the router, and the computer is also connected to the router.

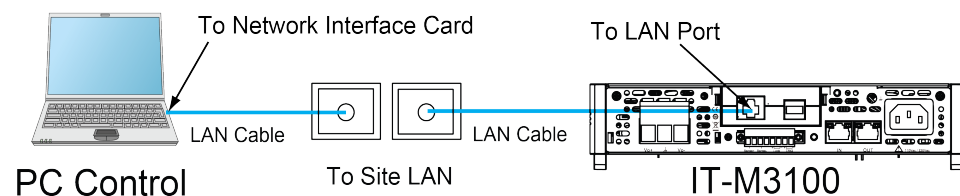



Note

- When using one crossover cable to connect PC directly, the gateway address should be consistent with that of the PC, and the IP address should be at the same network segment with the PC's IP address.
- When the instrument and computer are connected to the router, an independent IP address must be assigned for the instrument.

LAN Status Indicator

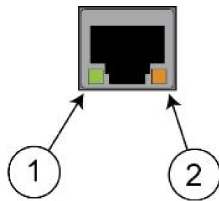
The lower icon notes the two status LEDs located at the bottom of the LAN port.



If neither of the LEDs is lit, the network is not connected.

- Position 1: When lit, it indicates that the LAN port is connected.
- Position 2: When flashing, it indicates that the LAN port is receiving or sending a message.

Configure LAN Interface Information

When shipped, DHCP is on, which may enable communication over LAN. The letters DHCP stands for Dynamic Host Configuration Protocol, a protocol for assigning dynamic IP addresses to devices on a network. With dynamic addressing, a device can have a different IP address every time it connects to the network. The user can view the related information of LAN interface or configure the communication parameters in system menu.

- Automatically configure the address of the instrument.(Auto)

When selected, the instrument will first try to obtain an IP address from a DHCP server. If a DHCP server is found, the DHCP server will assign an IP address, Subnet Mask, and Default Gateway to the instrument. If a DHCP server is unavailable, the instrument will try to obtain an IP address using AutoIP. AutoIP automatically assigns an IP address, Subnet Mask, and Default Gateway addresses on networks that do not have a DHCP server.

- Manually configure the address of the instrument.(Manual)

Set the following parameter. The following information only appear when Manual is selected.

- IP Addr: This value is the Internet Protocol (IP) address of the instrument. An IP address is required for all IP and TCP/IP communications with the instrument. An IP Address consists of 4 decimal numbers separated by

periods. Each decimal number ranges from 0 through 255 with no leading zeros (for example, 169.254.2.20).

- Sub Net: This value is used to enable the instrument to determine if a client IP address is on the same local subnet. The same numbering notation applies as for the IP Address. When a client IP address is on a different subnet, all packets must be sent to the Default Gateway.
- Gateway: This value is the IP Address of the default gateway that allows the instrument to communicate with systems that are not on the local subnet, as determined by the subnet mask setting. The same numbering notation applies as for the IP Address. A value of 0.0.0.0 indicates that no default gateway is defined.
- DNS1: This field enters the primary address of the server. Contact your LAN administrator for server details. The same numbering notation applies as for the IP Address. A value of 0.0.0.0 indicates that no default server is defined.

DNS is an internet service that translates domain names into IP addresses. It is also needed for the instrument to find and display its host-name assigned by the network. Normally, DHCP discovers the DNS address information; you only need to change this if DHCP is unused or not functional.

- DNS2: This field enters the secondary address of the server. Contact your LAN administrator for server details. The same numbering notation applies as for the IP Address. A value of 0.0.0.0 indicates that no default server is defined.
- Socket Port: This field indicates the port number corresponding to the RawSocket service.

The operation steps to configure are as follows.

1. Press **[Shift]+[Save]** (System) to enter into the system menu interface.
2. Use left and right keys or rotate the knob to select **Comm** and press **[Enter]** key to confirm.
3. Use left and right keys or rotate the knob to select **LAN** and press **[Enter]** key to confirm.
4. Use left and right keys or rotate the knob to select **Lan Config** and press **[Enter]** key to confirm.

The first displayed menu item **IP Mode** is to configure the instrument address.

5. Press **[Enter]** key to confirm. This parameter is in modification.
 - Auto: automatically configure the addressing of the instrument;
 - Manual: manually configure the addressing of the instrument.
 If Manual is selected, set the parameters such as IP Addr and Sub Net.

6. After setting, press **[Esc]** to exit.

Confirm the LAN Setting

After configuring the LAN settings, the user need to confirm the settings to make it valid in the instrument. The operation steps to confirm the LAN settings are as follows.

1. Press **[Shift]+[Save]** (System) to enter into the system menu interface.
2. Use left and right keys or rotate the knob to select **Comm** and press **[Enter]** key to confirm.
3. Use left and right keys or rotate the knob to select **LAN** and press **[Enter]** key to confirm.
4. Use left and right keys or rotate the knob to select **Lan Save** and press **[Enter]** key to confirm.
 - NO: indicates refuse to save the LAN setting.
 - YES: indicates save the LAN setting.
5. After setting, press **[Esc]** to exit.

Reset the LAN to the Default Settings

The operation steps to reset the LAN to the default settings are as follows.

1. Press **[Shift]+[Save]** (System) to enter into the system menu interface.
2. Use left and right keys or rotate the knob to select **Comm** and press **[Enter]** key to confirm.
3. Use left and right keys or rotate the knob to select **LAN** and press **[Enter]** key to confirm.
4. Use left and right keys or rotate the knob to select **Lan Restore** and press **[Enter]** key to confirm.
 - NO: indicates refuse to reset the LAN to the default settings.
 - YES: indicates reset the LAN to the default settings.
5. After setting, press **[Esc]** to exit.

View LAN Interface Information

The operation steps to view the LAN interface information are as follows.

1. Press **[Shift]+[Save]** (System) to enter into the system menu interface.
2. Use left and right keys or rotate the knob to select **Comm** and press **[Enter]** key to confirm.
3. Use left and right keys or rotate the knob to select **LAN** and press **[Enter]** key to confirm.

The first displayed menu item **Lan Info** is to view the LAN interface information.

4. Press **[Enter]** key to confirm.

5. Use left and right keys or rotate the knob to view the LAN interface information. Refer to [System Menu](#) for more information.
6. After setting, press **[Esc]** to exit.

2.7.2.1 Web Interface

The instrument has a built-in Web interface for monitoring and controlling the instrument via a Web browser. To use the Web interface, connect the instrument and PC over LAN and enter the instrument's IP address into the address bar at the top of your PC's Web browser, you can access the front panel control functions including the LAN configuration parameters.

The address format to be entered in the browser's address bar is: `http://192.168.200.100`

192.168.200.100 is the default IP address. If it has been changed by the user, replace this IP with the actual configuration found in the instrument's Communication Menu.



Note

The instrument supports simultaneous connection to up to 6 computers. If there are more connections, the instrument performance will be reduced.

As shipped, the login password of the Web interface defaults to 12345678. To change the password, click the Security button in the navigation bar on the left side of the window after login.

Enter the password and then click the LOGIN button, the Web interface will appear in the browser as shown below. The following figure is just as an example and the Web interface of different models are different. The actual shown page shall be subject to the connected instrument.

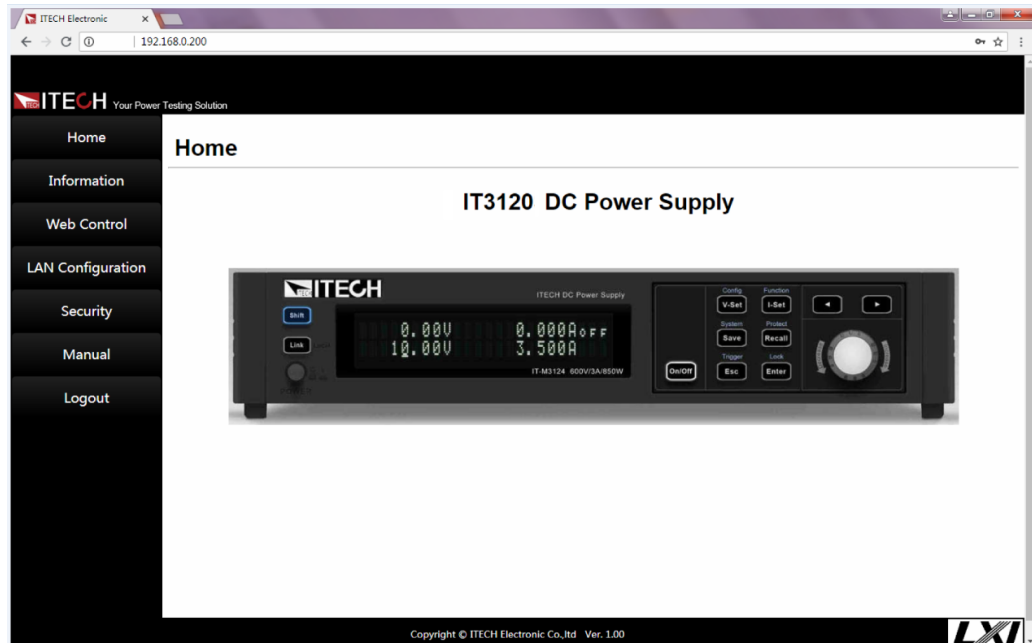

You can select different interfaces by clicking the seven buttons shown in the navigation bar on the left side of the window. The detailed descriptions are as follows.

- Home: Web home interface, displays the model and appearance of the instrument;
- Information: displays the serial number of the instrument and more system information as well as LAN configuration parameters;
- Web Control: enables the Web control to begin controlling the instrument. This page allows you to monitor and control the instrument;
- LAN Configuration: reconfigure the LAN parameters;
- Security: change the password and control access to the Web interface;
- Manual: go to the ITECH official website and view or download the relevant documents;
- Logout: logout the Web interface.

2.7.2.2 Using Sockets

CAUTION

The instruments allow up to six simultaneous socket connections to be made.

ITECH instruments have SCPI socket services, which can be used to send and receive SCPI commands, queries, and query responses. All commands must be terminated with a newline for the message to be parsed. All query responses will also be terminated with a newline.

2.7.3 CAN Interface

When the optional interface card is RS232+CAN interface (IT-E1207), the following can help users quickly understand the steps required to connect to the CAN interface.

The following figure shows the CAN interface system. The user can select the CAN interface converter to connect to your computer according to the actual situation. Take the CAN to USB interface device as an example.

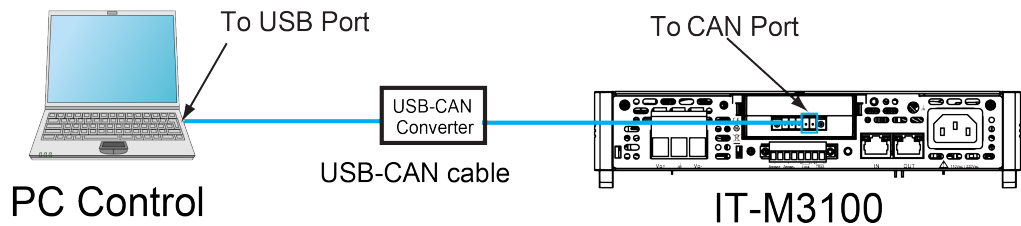

Note

The rear panel shown in the figure is only an example. The actual appearance of the rear panel is subject to the specific instrument.

Definition of CAN Pins

The definition of CAN pins are as follows.

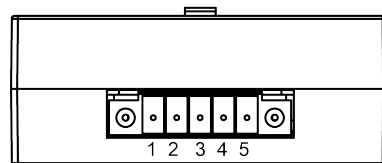

IT-E1207

Pin	Description
1	TXD, transmit data
2	RXD, receive data
3	GND
4	CAN_H
5	CAN_L

CAN Configuration

The user needs to configure the CAN interface parameters in the system menu before using the remote control. The CAN interface parameters are as follows.

Name	Description
Baud rate	Select the baud rate from the following options: 20k, 40k, 50k, 80k, 100k, 125k, 150k, 200k, 250k, 400k, 500k, 1000k.
Instrument Address	Range: 1 to 127

The operation steps are as follows.

1. Press **[Shift]+[Save]** (System) to enter into the system menu interface.
2. Use left and right keys or rotate the knob to select **Comm** and press **[Enter]** key to confirm.
3. Use left and right keys or rotate the knob to select **CAN** and press **[Enter]** key to confirm.
4. Use left and right keys or rotate the knob to select **Baud rate** and press **[Enter]** key to confirm.
5. Rotate the knob to set the baud rate and press **[Enter]** key to confirm.
6. Use left and right keys or rotate the knob to select **Address** and press **[Enter]** key to confirm.
7. Rotate the knob to set the communication address and press **[Enter]** key to confirm.
8. After finishing the setting, press **[Esc]** to exit.

CAN Troubleshooting

If you meet some problems when communicating with PC by CAN interface, please check the following items:

- PC and power supply must have the same baud rate.
- Ensure you have used the correct communication cable (CAN_H, CAN_L). Please pay attention that some cable may not have a correct internal wiring even it is with an appropriate interface.
- The interface cable is correctly connected (CAN_H to CAN_H, CAN_L to CAN_L)
- If the communication signal is poor or unstable, it is recommended to connect a 120 Ω terminating resistance.
 - The connection diagram of a single device is as below.

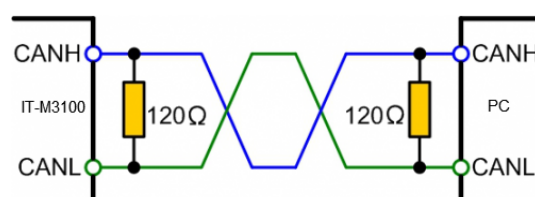

- The connection diagram of multiple devices is as below.

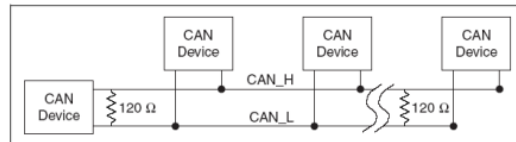

2.7.4 GPIB Interface

When the optional interface card is a GPIB interface (IT-E1205), you need to know the following.

Each device on the GPIB (IEEE-488) interface must have a unique whole number address between 0 and 30. Your computer's GPIB interface card address must not conflict with any instrument on the interface bus. This setting is non-volatile; it will not be changed by power cycling or *RST. The figure below shows a typical GPIB interface system.

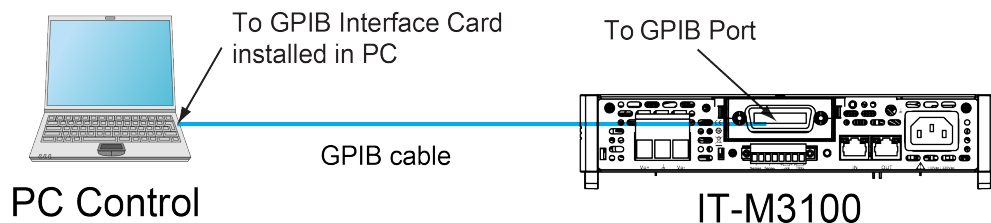

Note

The rear panel shown in the figure is only an example. The actual appearance of the rear panel is subject to the specific instrument.

You can change the GPIB address in the system menu. The operation steps are as follows.

1. Refer to the GPIB connection diagram, Connect the power supply and the computer using a IEEE-488 bus.
2. Set the GPIB address in the system menu.
 - a. Press **[Shift]+[Save]** (System) to enter into the system menu interface.
 - b. Use left and right keys or rotate the knob to select **Comm** and press **[Enter]** key to confirm.
 - c. Use left and right keys or rotate the knob to select **GPIB** and press **[Enter]** key to confirm.
 - d. Rotate the knob to adjust the GPIB address and press **[Enter]** key to confirm.
 - e. After finishing the setting, press **[Esc]** to exit.

2.7.5 RS-232 Interface

When the optional interface card is RS232+CAN interface (IT-E1207), the following can help users quickly understand the steps required to connect the RS-232 interface. The diagram below illustrates a typical RS-232 interface system, where the instrument is connected to a PC using a standard RS-232 cable (with a DB9 connector on one end and a straight terminal block on the other). The standard cable is described as follows:

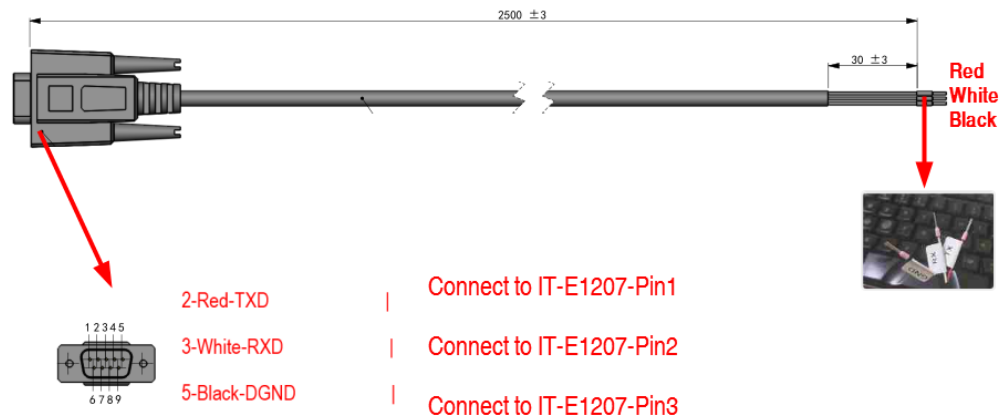

Wiring Method:

- TXD cable (red) connects to Pin 1 of the IT-E1207 board.
- RXD cable (white) connects to Pin 2 of the IT-E1207 board.
- DGND cable (black) connects to Pin 3 of the IT-E1207 board.

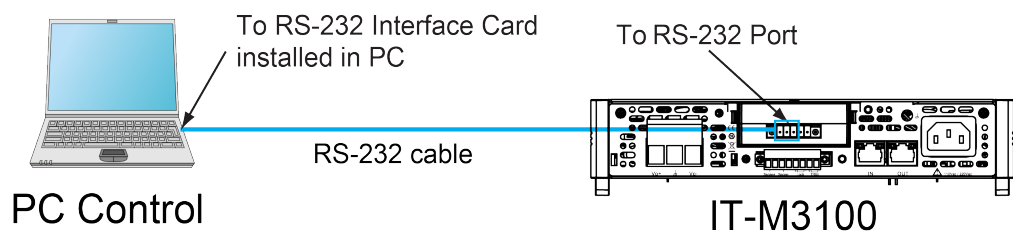

Note

- The rear panel shown in the diagram is for reference only; please refer to the actual instrument for the final appearance.
- If the PC is equipped with a DB9 port, the standard RS-232 cable can be connected directly via the DB9 end. If the PC has only USB ports, an RS-232-to-USB adapter cable must be used to connect to the PC. This type of adapter requires a driver to be properly recognized as a COM port. Please contact the adapter cable manufacturer for the appropriate driver installation.

Definition of RS-232 Pins

The definition of RS-232 pins are as follows.

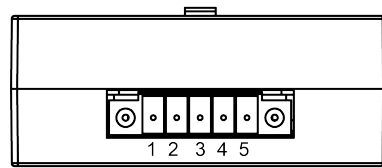

IT-E1207

Pin	Description
1	TXD, transmit data
2	RXD, receive data
3	GND
4	CAN_H
5	CAN_L

RS-232 Connection

The connection principle with the computer is shown in the following diagram:

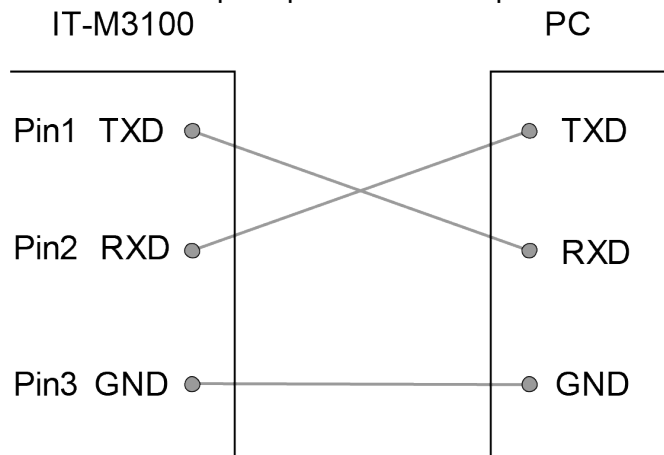

RS-232 Configuration

The user needs to configure the RS-232 interface parameters in the system menu before using the remote control. The RS-232 interface parameters are as follows.

Name	Description
Baud rate	Select the baud rate from the following options: 4800, 9600, 19200, 38400, 57600, 115200
Data Bit	8 (fixed)
parity bit	None (fixed)
stop bit	1 (fixed)

The operation steps are as follows.

1. Press **[Shift]+[Save]** (System) to enter into the system menu interface.

2. Use left and right keys or rotate the knob to select **Comm** and press **[Enter]** key to confirm.
3. Use left and right keys or rotate the knob to select **RS232** and press **[Enter]** key to confirm.

```
RS232
9600_8_None_1
```

4. Rotate the knob to set the baud rate.
5. After finishing the setting, press **[Esc]** to exit.

RS-232 Troubleshooting

If you meet some problems when communicating with PC by RS-232 interface, please check the following items:

- PC and power supply must have the same baud rate.
- Ensure you have used the correct communication cable. Please pay attention that some cable may not have a correct internal wiring even it is with an appropriate interface.
- The cable must be connected to the correct serial ports (COM1, COM2, etc) of PC.

2.7.6 RS-485 Interface

When the optional interface card is a DB25 analog interface (IT-E1208) with RS-485 interface, you can quickly understand the steps required to connect the RS-485 interface.

The following figure shows a typical RS-485 interface system. Users can select the RS-485 interface converter to connect to your computer according to the actual situation, for example: RS-485 to RS-232 interface device or RS-485 to USB interface device Etc., the RS-485 to USB interface device is taken as an example.

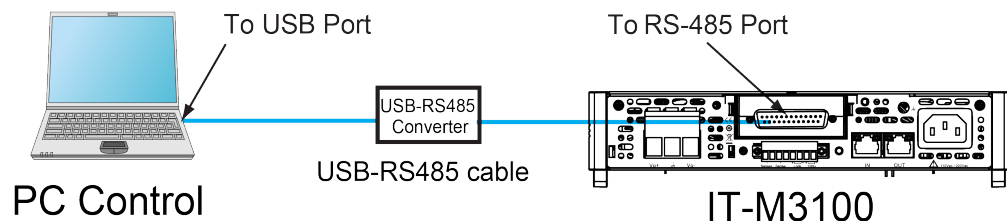

Note

The rear panel shown in the figure is only an example. The actual appearance of the rear panel is subject to the specific instrument.

Definition of RS-485 Pins

RS-485 interface pins are integrated in the DB25 analog interface. Pin25 and Pin13 are the A and B pins for RS-485. Refer to [Analog interface](#) for more information.

RS-485 Configuration

The user needs to configure the RS-485 interface parameters in the system menu before using the remote control. The RS-485 interface parameters are as follows.

Name	Description
Baud rate	Select the baud rate from the following options: 4800, 9600, 19200, 38400, 57600, 115200
Address	Set the communication address, range: 0~127.
Data Bit	8 (fixed)
Parity bit	None (fixed)
Stop bit	1 (fixed)

The operation steps are as follows.

1. Press **[Shift]+[Save]** (System) to enter into the system menu interface.
2. Use left and right keys or rotate the knob to select **Comm** and press **[Enter]** key to confirm.
3. Use left and right keys or rotate the knob to select **RS485** and press **[Enter]** key to confirm.

```
RS485
9600_8_None_1
```

4. Rotate the knob to set the baud rate and press **[Enter]** key to confirm.
5. Use left and right keys or rotate the knob to select **RS485 Addr** and press **[Enter]** key to enter the RS485 address setting interface.
6. Rotate the knob to set the communication address and press **[Enter]** to confirm.
7. After finishing the setting, press **[Esc]** to exit.

3 Getting Started

- ◆ Power-on the Instrument
- ◆ Set the Output Voltage
- ◆ Set the Output Current
- ◆ Use the Front Panel Menu
- ◆ Output On/Off Control

3.1 Power-on the Instrument

When you turn the POWER switch on for the first time after purchase, the instrument starts with its factory default settings. Each time thereafter, the instrument starts according to the setting that you selected as outlined in [4.2.2 Set the Power-on State](#).

Precautions

Before operation, please confirm that you have fully understood the safety instructions.

WARNING

- **Before connecting power cord, be sure to confirm that the power voltage matches with the supply voltage.**
- **Ensure that the input electrodes are either insulated or covered using the safety covers provided, so that no accidental contact with lethal voltages can occur.**
- **If you notice strange sounds, unusual odors, fire, or smoke around or from inside the instrument, flip the POWER switch to the (O) side to turn the instrument off, or remove the power cord plug from the outlet. The detachable power cord may be used as an emergency disconnecting device. Removing the power cord will disconnect AC input power to the unit.**

Power Switch Introduction

The power switch is located in the lower left corner of the front panel. The power switch is a button, and pressing once indicates ON and pressing again indicates OFF.

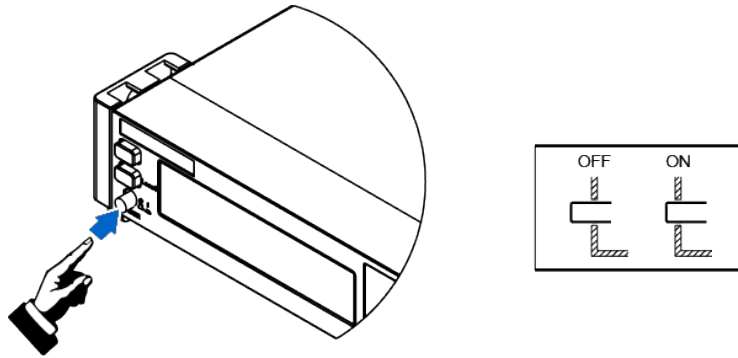

Turning the POWER Switch On

Check that the power cord is connected properly.

Flip the POWER switch to the (|) side to turn the instrument on. The front panel display will light up after a few seconds. It may take about 30 seconds or so for the power supply to initialize before it is ready for use.

If a self-test error occurs, an error message will be displayed in the front panel. Press the **[Esc]** button to try to clear the current fault status. The user can also restart the instrument to try to clear the fault status. Wait until the power is turned off and then start again. If the problem still cannot be solved after restarting, please contact the ITECH engineer. Common error messages are shown in the following table:

Error Messages	Description
Module Init Lost	The module information is lost.
Cal User Data Lose	User calibration information is lost.
Cal Factory Data Lose	Factory calibration information is lost.
Fan 1 Error!	Fan 1 is abnormal.
Fan 2 Error!	Fan 2 is abnormal
Chan Number Conflict	The channel number is conflict.
Ms Group Confcit	The master group is conflict.
Search Slave	The instrument is searching the slave.
Wait For Master	The instrument is waiting the master.
EEProm Failure	EEProm is broken.

**Note**

The instrument takes approximately 30 seconds to initialize before it is ready for use.

Turning the POWER Switch Off

Flip the POWER switch to the (O) side to turn the instrument off. When it is turned off, the instrument interface will prompt “Power Down”, and the instrument will store the setting information before shutdown in the group 1 non-volatile memory.

After you turn the POWER switch off, wait at least 10 seconds after the fan stops before you turn the POWER switch back on. Turning the instrument on too soon after you turn it off can cause damage to the inrush current limiter circuit, as well as reduce the life of components such as the POWER switch and the internal input fuses.

3.2 Set the Output Voltage

The voltage setting range is from 0 V to the maximum rated output voltage. When **[V-set]** key is pressed, the key light is lit and the output voltage value can be set. Press right and left keys to move the cursor and rotate the knob to adjust the voltage value in voltage setting filed.

3.3 Set the Output Current

The current setting range is from 0 A to the maximum rated output current. When **[I-set]** key is pressed, the key light is lit and the output current value can be set. Press right and left keys to move the cursor and rotate the knob to adjust the current value in current setting filed.

3.4 Use the Front Panel Menu

The front panel command menu lets you access most of the instrument’s functions. Briefly:

- Press the corresponding composite button to access the menu of the desired settings.
- Use the left and right arrow keys or knob to move through the menu. Each menu item is preceded by a number.

- Press **[Enter]** to change the current menu item to the state to be edited, or select a command and move to the next level in the menu. In addition, after changing the setting you need to press **[Enter]** to save.
- Press **[Esc]** to return to the previous menu. When performing any function key operation, press **[Esc]** key to exit the function operation state.

Please refer to [1.7 Front Panel Menu Reference](#) for the detailed map of the front panel menus.

3.5 Output On/Off Control

WARNING

- The **[On/Off]** key light is off and turning the output off does not place the instrument in a safe state. Hazardous voltages may be present on all output and guard terminals. Putting the equipment into an output-off state does not guarantee that the outputs are powered off if a hardware or software fault occurs. See the cautions about connecting the test lines before connecting test lines.
 - To prevent electrical shock that could cause injury or death, please ensure that the power supply and DUT have been connected well before you turn the output on.
 - If the power supply has no output after the output is turned on, please check whether the output lock interface Lock± of the power supply is shorted. Remove any jumper or shorting clip between Lock+ and Lock- to output normally. For details, please see [4.1.4 Output Lock Control](#).
 - The **[On/Off]** key is used to turn the output on or off under normal circumstances. Even if the instrument is in control by PC or the keyboard is locked, the **[On/Off]** is still valid.
-

Press the **[On/Off]** key on the front panel to turn the output on and the **[On/Off]** key light is lit. Press the **[On/Off]** key again to turn the output off and the **[On/Off]** key light goes out. When the power supply is in the output-off state, the VFD displays that the power supply state is OFF. When the power supply is in the output-on state, the VFD displays that the power supply state switches to CC or CV.

4 Functions and Features

This chapter describes in detail the functions and features of the instrument, including the following sections:

- ◆ Output Function
- ◆ System-Related Operations
- ◆ Multi-Machine Operation
- ◆ Protection Function
- ◆ List Function
- ◆ Battery Charging Test Function
- ◆ External Analog Function (Option)

IT-M3100 series power supplies have the following three operating modes:

- Fixed mode: This is the default mode when the power supply is powered on. In fixed mode, the output parameters, protection function and such regular operations all can be set.
- List mode: Once enter the list function setting interface, the instrument automatically enters into the list mode. In list mode, the user can create a test program made of multiple steps. The setting parameters in list mode are only valid for list operation.
- Battery mode: IT-M3100 series power supplies provide battery charging test function. When use the battery function, the instrument automatically enters into the battery mode. The setting parameters in battery mode are only valid for battery operation.

4.1 Output Function

WARNING

SHOCK HAZARD, LETHAL VOLTAGES Many models generate voltages greater than 600 VDC! Ensure that all instrument connections are either insulated or covered using the safety covers provided, so that no accidental contact with lethal voltages can occur.

4.1.1 Set the Output Priority Mode

- Voltage priority mode keeps the output voltage constant. In voltage priority mode, the output voltage should be set to the desired value. The output is

controlled by a constant-voltage feedback loop, which maintains the output voltage at its programmed setting.

- Current priority mode keeps the output current constant. In current priority mode, the output current should be set to the desired value. The output is controlled by a constant-current feedback loop, which maintains the output current at its programmed setting.

The procedures to set the output priority mode are as follows.

1. Press **[Shift]+[V-set]**(Config) to enter into the configuration menu interface.
2. Use knob or left and right keys to select **Mode**, press **[Enter]** to confirm.
3. Select **CC Priority** or **CV Priority**, press **[Enter]** to enter into the setting interface.
 - Select **CV Priority**, the menu displays V-Rise Time and V-Fall Time.
 - Select **CC Priority**, the menu displays I-Rise Time and I-Fall Time.
4. Select the desired menu item, press **[Enter]** to confirm.
5. Use knob to adjust the values and press **[Enter]** to confirm.

4.1.2 Set the Output-On/Output-Off Delay Time

You can set the output-on/output-off delay time within the range from 0 seconds to 10 seconds. During the output delay time, the VFD displays  on the top right corner. Once the output-on delay timer expires, the VFD displays "CC" or "CV". Once the output-off delay timer expires, the VFD displays "OFF".

- On Delay is from the time that a command to turn on the output is received until the output actually turns on.
- Off Delay is from the time that a command to turn off the output is received until the output actually turns off.

The procedures to set the output delay time are as follows.

1. Press **[Shift]+[V-set]**(Config) to enter into the configuration menu interface.
2. Use knob or left and right keys to select **On Delay** or **Off Delay** and press **[Enter]** to confirm.
3. Use knob to adjust the output-on/output-off delay time and press **[Enter]** to confirm.

4.1.3 Set the Output Timer Function

You can set the output timer within the range from 1 seconds to 86400 seconds. Once the timer expires, the output is turned off.

During the timing output, if the front panel has no operation for more than 5 seconds, the display will show the current output time of the timer: 00:00:05 (hour:

minute:second). Press any button (except **[Shift]** key, **[Link]** key) to exit the timing display page.

The procedures to set the output timer are as follows.

1. Press **[Shift]+[V-set]**(Config) to enter into the configuration menu interface.
2. Use knob or left and right keys to select **Timer** and press **[Enter]** to confirm.
3. Use knob or left and right keys to select **On** to turn the timer function on and press **[Enter]** to confirm.
4. Use knob to adjust the output **Time** and press **[Enter]** to confirm.

4.1.4 Output Lock Control

The IT-M3100 series power supply's rear panel provides an output lock interface, Lock±, which can disable the power output to prevent accidental operation of the power supply during testing, leading to damage to the DUT (Device Under Test). Before using this feature, it is necessary to configure the working mode and pin control logic of the Lock Port, as detailed below.

It is generally recommended to first verify the settings of **System**→**Lock Port**→**Polar**, that is, the logic level of the Lock± pins.

- Normal (Default): When the Lock+ and Lock- are **short-circuited**, the input to the Lock± pins is **True**; if **open-circuited**, then it is **False**.
- Inverse: When the Lock+ and Lock- are **short-circuited**, the input to the Lock± pins is **False**; if **open-circuited**, then it is **True**.

The image below shows the short-circuiting between the Lock± pins.

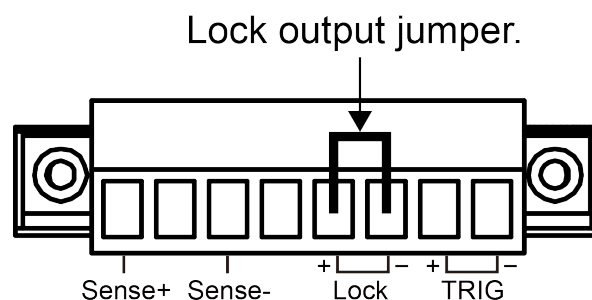

Next, configure the working mode for output disable (Inhibit) and DC emergency stop, that is, the settings of **System**→**Lock Port**→**Mode**.

- Off (Default): Disables the Inhibit function.
- Living: When the input to the Lock± pins is **True**, output is disabled, but the state of the output **[On/Off]** is not changed, and the output voltage becomes 0V. The output is restored when the input to the Lock± pins becomes **False**.

- Latch: When the input to the Lock± pins is **True**, output is disabled, and the output **[On/Off]** changes from ON to OFF, with a screen prompt indicating protection. The output is restored only after the input to the Lock± pins becomes **False** and the protection is cleared by pressing **[Esc]**, followed by turning on the **[On/Off]**.

4.2 System-Related Operations

Though not directly related to output programming, the following functions also control instrument operation.

4.2.1 Set the Key Beeper

The user can turn the instrument beeper sound on or off base on personal requirement. The beeper sound works in the following scenarios:

- A beeper sound produced when the front panel key is pressed.
- When an error is generated inside the instrument, such as when the instrument receives an unprocessed command in the remote state.

The procedures to set the key beeper are as follows.

1. Press **[Shift]+[Save]** (System) to enter into the system menu interface.

The first displayed menu item **Beep** is to set the key beeper.

2. Press **[Enter]** key and the parameter is in modification.
3. Rotate the knob to adjust the value.
 - On: default value, indicates the beeper is on.
 - Off: indicates the beeper is off.
4. Press **[Enter]** key to confirm.

At this point, the beeper sound operation immediately becomes valid.

4.2.2 Set the Power-on State

This menu item is used to control the settings and output state when the power supply is powered on.

The detailed power-on parameters and output state are as follows.

- The voltage and current setting values displayed on the main screen.
- The output state of the power supply, i.e., the **[On/Off]** key state.

The procedures to set the menu item are as follows.

1. Press **[Shift]+[Save]** (System) to enter into the system menu interface.
2. Use left and right keys or rotate the knob to select **PowerOn** and press **[Enter]** key to make the parameter in modification.
3. Rotate the knob to select the value from the following options.
 - **Reset**: default value, indicates when the power supply is powered on, the power supply will initialize some settings and output state.
 - **Last**: indicates when powered on, the power supply will remain the same settings and output state as last time you turned off the power supply.
 - **Last+Off**: indicates when powered on, the power supply will remain the same settings as last time you turned off the power supply, but the output state is OFF state.
4. After finishing the setting, press **[Enter]** key to confirm.

4.2.3 Set the Sense Function State

This menu item is used to switch the power supply to local sensing or remote sensing.

IT-M3100 series power supplies support two connection methods between power supply and device under test (DUT): Local sensing and Remote sensing. The remote sensing is used for maximizing measurement accuracy. (Refer to [2.6 Connecting the Device Under Test \(DUT\)](#) for more information.)

The procedures to set the menu item are as follows.

1. Press **[Shift]+[Save]** (System) to enter into the system menu interface.
2. Use left and right keys or rotate the knob to select **Sense** and press **[Enter]** key to make the parameter in modification.
3. Rotate the knob to select the value from the following options.
 - **Off**: default value, indicates turn the sense function off.
 - **On**: indicates turn the sense function on.
4. After finishing the setting, press **[Enter]** key to confirm.

4.2.4 Set the Communication Information

This menu item is used to set the communication information between instrument and PC. There is no standard communication interfaces for this series

power supplies. You can select GPIB, USB, RS-485, RS-232, CAN or LAN interface based on personal requirement.

The procedures to set the menu item are as follows.

1. Press **[Shift]+[Save]** (System) to enter into the system menu interface.
2. Use left and right keys or rotate the knob to select **Comm** and press **[Enter]** key to make the parameter in modification.

The menu displays the corresponding interface information automatically based on the inserted communication board.

3. Use left and right keys or rotate the knob to adjust the values.
4. After finishing the setting, press **[Enter]** key to confirm.



Note

Please refer to [2.7 Connect the Communication Interface](#) for the detailed description of each communication interface.

4.2.5 Set the Bleeder State (Bleeder)

This menu item is used to set the status of the bleeder circuit (**Bleeder**). **On** and **Off** apply to the following test scenarios:

- **On** (default): For test scenarios other than battery charging tests. After the **Bleeder** is turned on, when the test is finished and the output is turned off, the voltage can be dropped quickly.
- **Off**: For battery charging test scenarios. Since some devices inside the instrument can absorb power, when the test is finished and the battery is still connected to the test circuit, these devices will still discharge the battery even if the output is turned off or the instrument is powered off. Therefore, before connecting the battery to the test circuit, set **Bleeder** to **Off** to disconnect the bleeder circuit to avoid this problem.



Note

Turning off the **Bleeder** can omit the diode which is used to prevent reverse current during battery testing.

The procedures to set the menu item are as follows.

1. Press **[Shift]+[Save]** (System) to enter into the system menu interface.
2. Use left and right keys or rotate the knob to select **Bleeder** and press **[Enter]** key to make the parameter in modification.
3. Rotate the knob to select **Off** or **On** and press **[Enter]** key to confirm.

4.2.6 Set the TRIG± Interface Status (Ext IO)

The TRIG± interface is located on the rear panel of the instrument. For details, see [1.6 Rear-Panel Overview](#). The TRIG± interface allows a trigger signal to be applied to the instrument or a trigger signal from the instrument.

- Trig In: When the trigger source is set to **Ext**, inputting a 0V low-level signal (or short-circuiting the TRIG± pins) can generate a trigger.
- Trig Out: When the trigger source is set to **Keypad** or **Bus** and the trigger happens, the TRIG± interface generates a high pulse trigger signal.
- On Sync Out: As the indication signal of the instrument output status. When the output is OFF, the pins output 0V low level; when the output is ON, the pins output 5V high level.
- On Sync In: Used to control the output state of the instrument. Input 0V low level to the pins, the instrument output is OFF; input 5V high level to the pins, the instrument output is ON.

The procedures to set the menu item are as follows.

1. Press **[Shift]+[Save]** (System) to enter into the system menu interface.
2. Use left and right keys or rotate the knob to select **Ext IO** and press **[Enter]** key to make the parameter in modification.
3. Rotate the knob to set and press **[Enter]** key to confirm.

4.2.7 Select Trigger Source(Trig Source)

This menu item is used to select the trigger source.

IT-M3100 series power supply supports the following trigger sources:

- Keypad: Select the front panel **[Shift]+[Esc]** (Trigger) button as the trigger source;
- Bus: Select the remote interface command as the trigger source, such as the ***TRG** command;
- Ext: Select the rear panel trigger signal interface TRIG± (IN status) as the trigger source. Please refer to [4.2.6 Set the TRIG± Interface Status \(Ext IO\)](#) for detailed information about TRIG± interface status settings.

The procedures to set the menu item are as follows.

1. Press **[Shift]+[Save]** (System) to enter into the system menu interface.
2. Use left and right keys or rotate the knob to select **Trig Source** and press **[Enter]** key to make the parameter in modification.
3. Rotate the knob to adjust the parameter.
4. After setting, press **[Enter]** key to confirm.

4.2.8 Restore the Factory Default Settings

This menu item is used to restore the factory default settings.

The procedures to set the menu item are as follows.

1. Press **[Shift]+[Save]** (System) to enter into the system menu interface.
2. Use left and right keys or rotate the knob to select **System Reset** and press **[Enter]** key to make the parameter in modification.
3. Use left and right keys or rotate the knob to select the value from the following options.
 - No: default value, indicates the power supply cancels this menu setting.
 - Yes: indicates the power supply restores the factory default settings.
4. After finishing the setting, press **[Enter]** key to confirm.

The detailed default parameters are listed in the following table.

Parameter	Default Value
Voltage	0
Current	MAX
P-Set	MAX (Only supported for IT-M3130/IT-M3131/IT-M3132/IT-M3133/IT-M3134/IT-M3135/IT-M3116/IT-M3126/IT-M3136 models.)
Mode	CV Priority
V-Rise Time	0.025 S
V-Fall Time	0.100 S
I-Rise Time	0.025 S
I-Fall Time	0.100 S
On Delay	0.000 S
Off Delay	0.000 S
Timer	Off
Time	1.0 S

Parameter	Default Value
Beep	On
Power On	Reset
Sense	Off
USB mode	TMC
IP Addr	192.168.200.100
Sub Net	255.255.255.0
Gateway	192.168.200.1
DNS1	192.168.200.1
DNS2	192.168.200.2
Socket Port	30000
RS232	9600_8_None_1
CAN Baud rate	250k
CAN Address	1
EXT-Program	Off
RS-485	9600_8_None_1
GPIB	15
SCPI	Default
Parallel Mode	Single
Link Status	Offline
Link Mode	On/Off Only
Chan Number	1
Bleeder	On
Ext IO	Trig Out
Trig Source	Keypad
Lock Port Mode	Off
U Max Level	MAX
U Min Level	0.00 V
P Max Level	MAX (Only supported for IT-M3110/ IT-M3111/IT-M3112/IT-M3113/IT-

Parameter	Default Value
	M3114/IT-M3115/IT-M3120/IT-M3121/ IT-M3122/IT-M3123/IT-M3124/IT- M3125/IT-M3120S/IT-M3112S models.)
OVP Mode	Off
OVP Level	MAX
OVP Delay	10.00 S
OCP Mode	Off
OCP Level	MAX
OCP Dealy	10.00 S
OPP Mode	Off
OPP Level	MAX
OPP Delay	10.00 S
UVP Mode	Off
UVP Level	0.00 V
UVP Delay	10.00 S
UVP Warm	30.00 S
UCP Mode	Off
UCP Level	0.000 A
UCP Delay	10.00 S
UCP Warm	30.00 S
Foldback	Off

4.2.9 View the System Information

This menu item is used to view the system information of the instrument.

The procedures to view the system information are as follows.

1. Press **[Shift]+[Save]** (System) to enter into the system menu interface.
2. Use left and right keys or rotate the knob to select **System Info** and press **[Enter]** key to make the parameter in modification.

The user can use left and right keys or knob to view the following system information.

Name	Description
Model	The instrument model
ArmVer	The control board version
CommVer	The communication board version
DSPVer	DSP version Only displayed for models IT-M3130/IT-M3131/IT-M3132/IT-M3133/IT-M3134/IT-M3135/IT-M3116/IT-M3126/IT-M3136.
SN	The serial number
Last Cal	Last calibration date
Run Time	Instrument running time

4.2.10 Switch Local/Remote Mode

This series power supplies provide local operation and remote operation. The default mode is local operation mode.

- Local operation mode: use front panel keys to control the power supply.
- Remote operation mode: the power supply is connected to PC, the user uses the software in PC to control the power supply remotely.

During remote control operation, the remote symbol  is displayed at the top right corner of the front panel display. All panel keys, except the **[On/Off]** and **[Shift]+[Link]** (Local) keys, are locked.

You can press **[Shift]+[Link]** (Local) to switch the remote control to local control. The mode modification will not affect the output parameters.

4.2.11 Key Lock Function

The front panel controls can be locked to protect from accidental power supply parameter change. Press **[Shift]+[Enter]** (Lock) to lock front panel keys and the lock symbol  is shown on the front panel display. All panel keys, except the **[On/Off]** and **[Shift]+[Enter]** (Lock) keys, are locked. You can repress **[Shift]+[Enter]** (Lock) to unlock the front panel.

4.2.12 Save and Recall Operations

This series power supplies can save up to 10 common parameters in non-volatile memory (No. 1 to No. 10) for user to recall conveniently.



Note

The instrument provides a power-down save function. When the power is turned off, the setting information before shutdown is automatically stored in the first group of non-volatile memory.

The saved settings include the following parameters.

- The voltage setting value;
- The current setting value.

You can do the save and recall operations by the following two methods.

- Front panel keys: **[Save]** and **[Recall]** ;
- SCPI command: *SAV and *RCL.

Save Operations

1. Press **[Save]** to enter into the saving interface.
2. Set the storage location.

Use knob to adjust a value from 1 to 10 on the prompt interface "Save File = 1" to set the storage location in non-volatile memory.

3. Press **[Enter]** key to confirm.

Recall Operations

You can recall the parameters you saved in the specified memory location as the setting values.

1. Press **[Recall]** to enter into the saving interface.
2. Set the recall location.

Use knob to adjust a value from 1 to 10 on the prompt interface "Recall File = 1" to set the recall location in non-volatile memory.

The second lines displays the stored voltage and current values in the specified memory location

3. Press **[Enter]** key to confirm the recall operation.

4.3 Multi-Machine Operation

WARNING

SHOCK HAZARD All paralleled units must be connected to ground through a grounded power cord at all times. Any interruption of the protective (grounding) conductor or disconnection of the protective earth terminal on any unit will cause a potential shock hazard that could result in injury or death.

Function Introduction

The multi-machine operation refers to connecting multiple instruments according to a fixed wiring mode through the System Bus interface to realize multi-channel, parallel, and synchronous control functions. The following is a general introduction to these three functions:

Type	Introduction	Maximum Quantity	Model Restriction	Communication Object
Multi-channel	Only can be used in the PC software (IT9000). By communicating one unit in the System Bus link with the PC, it is possible to independently control any other unit in the PC software.	A maximum of 16 units can be connected in each System Bus link.	Multi-channel systems can be composed of single units of the same series and different models.	Any unit in each System Bus link
Synchronization	By operating one unit in the System Bus link locally or remotely, it is possible to synchronously control the On/Off and equal-scale output of the other units.	A maximum of 16 units can be connected in each System Bus link.	Synchronization systems can be composed of single units of the same series and different models.	Any unit in each System Bus link
Parallel	The single units in the System Bus link are connected in parallel to form a parallel system (group) to achieve higher power and current output. At the same time, multiple parallel systems (groups) can form a multi-channel or synchronous system.	Each parallel system (group) supports up to four single units (1 master and 3 slaves) for parallel connection. Each system bus link can connect up to 16 single units.	The units models in each parallel system (group) must be the same. Multi-channel or synchronization systems can be composed of multiple parallel systems (groups) on a System Bus link, and the units in Group A and Group B can be the same series but different models.	Master unit in any parallel system (group)

The schematic diagram of multi-channel and synchronous links is as follows:

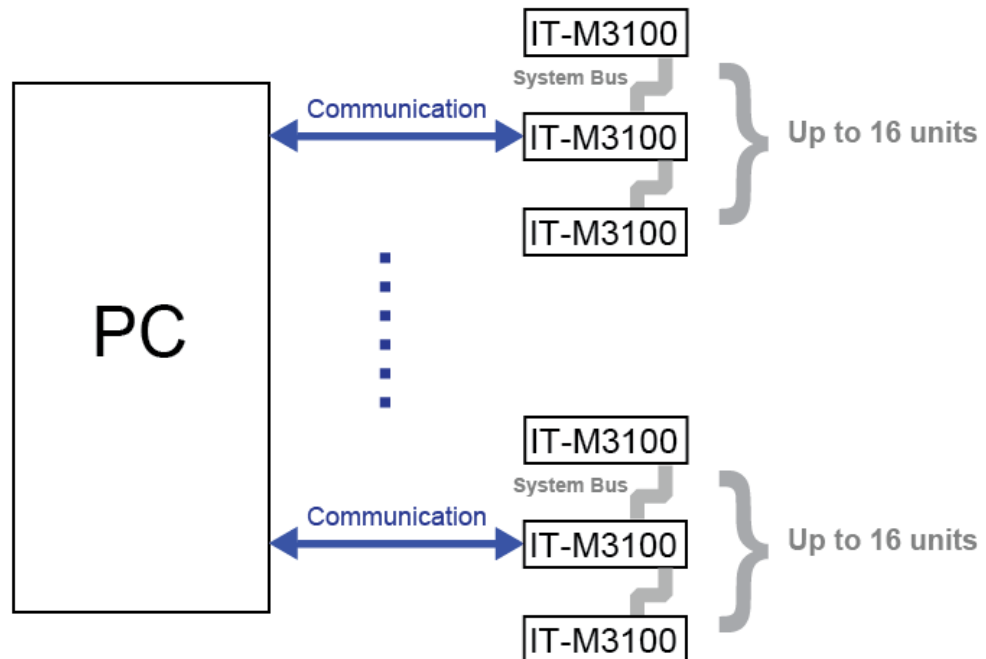

The schematic diagram of parallel links is as follows:

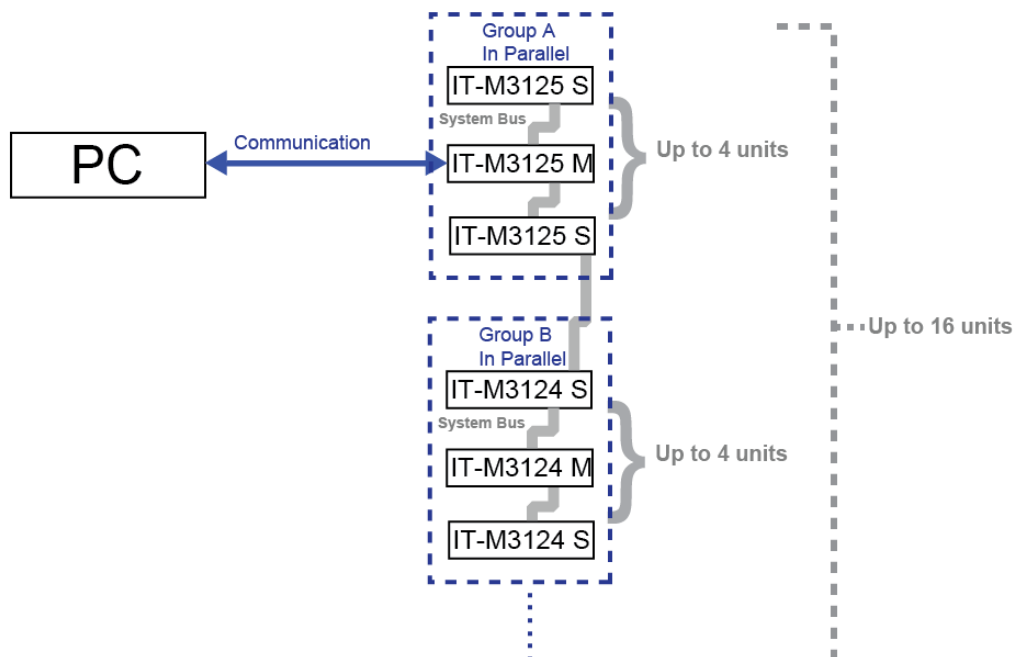

4.3.1 Multi-Channel Function

When multiple power supplies are connected through the System Bus interface, each power supply must be set to a separate channel number ranging from 1 to 16. The power supply connected to the same system bus, the channel number

can not be repeated, otherwise it will cause conflicts. All power interfaces will prompt “Chan Number Conflict”. In this case, rotate the knob to change the channel number directly, press **[Enter]** to confirm.

After forming a multi-channel power system, the channel number is displayed on each instrument interface. Connect the communication interface of one of the power supplies to the PC, then the user can independently control each power supply of the system in the PC software. The following three power supplies are taken as an example to describe the connection and operation steps of multiple channels.

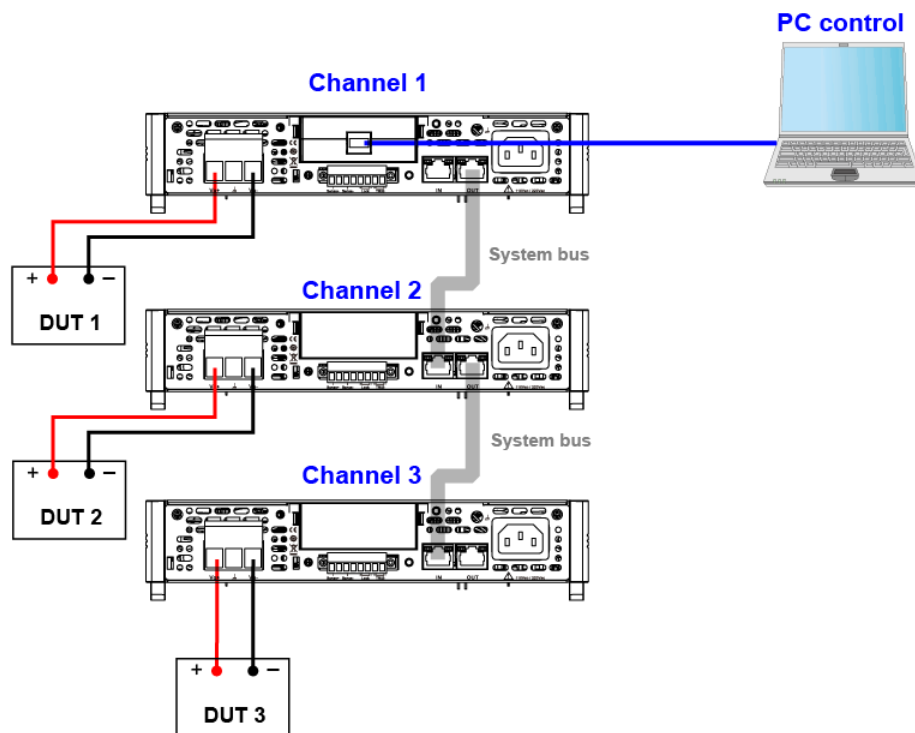

Note

The rear panel shown in the figure is only an example. The actual appearance of the rear panel is subject to the specific instrument.

The procedures to set the channel number are as follows.

1. Set the channel number for each instrument.
 - a. Press **[Shift]+[Save]** (System) to enter into the system menu interface.
 - b. Use left and right keys or rotate the knob to select **Chan Number** and press **[Enter]** key to make the parameter in modification.
 - c. Rotate the knob to adjust the value and set the channel number. Press **[Enter]**.
 - d. Repeat steps a through c to set the channel number for other power supplies.

2. Connect the instruments according to the above diagram. Please disconnect the power before wiring.
 - a. Connect system bus interfaces.
 - b. Connect the DUTs. Refer to [2.6 Connecting the Device Under Test \(DUT\)](#) for more information about connection methods.
 - c. Connect the power supply to PC.
3. After power-on, if the interface prompts “Chan Number Conflict”, rotate the knob to change the channel number directly.

4.3.2 Parallel Function (Parallel)

Parallel operation allows the user to connect multiple power supplies simultaneously to create a system with higher total current and power. Multiple parallel systems can be connected to the same system bus according to different groups, which is convenient for unified control on the PC.

Up to sixteen power supplies can be connected to the same system bus. Up to four power supplies of the same model can be connected in parallel in the same group. The power supply models can be different between different groups. In each group, one power supply must be the master unit and all other power supplies connected in parallel are slave units. All features are set up from the master unit.



Note

Before configuring the parallel parameters, the user must firstly configure the channel number of each instrument. Please refer to [4.3.1 Multi-Channel Function](#) for detailed introduction.

Take one group and three groups configuration for instance, the following content show the connection methods respectively.

Configure One Group

Take three power supplies for instance, set them to one master unit and two slave units. The detailed connection method and procedures are as follows.

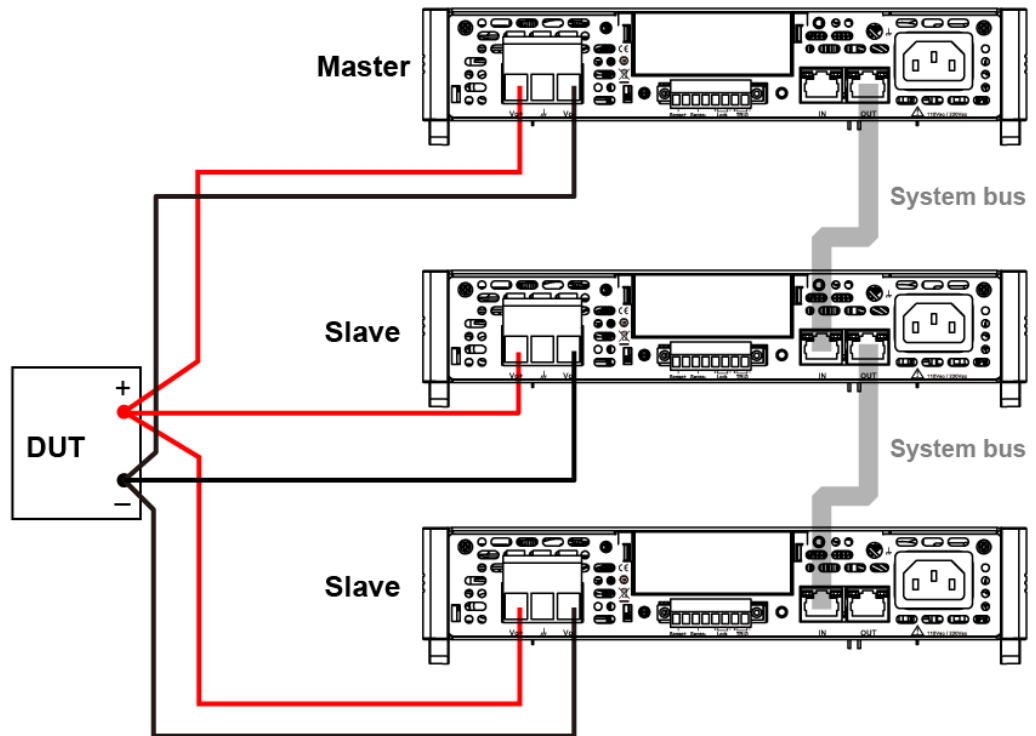
Note

The rear panel shown in the figure is only an example. The actual appearance of the rear panel is subject to the specific instrument.

1. Configure the channel number of each instrument. Please refer to [4.3.1 Multi-Channel Function](#) for detailed introduction.
2. Connect the instruments according to the above diagram.
 - a. Connect system bus interfaces. Before connecting the system bus, be sure that the instrument is single mode.
 - b. Connect the DUTs. Refer to [2.6 Connecting the Device Under Test \(DUT\)](#) for more information about connection methods.
3. After finishing connection, configure one power supply as a master unit.
 - a. Press **[Shift]+[Save]** (System) to enter into the system menu interface.
 - b. Use left and right keys or rotate the knob to select **Parallel** and press **[Enter]** key to make the parameter in modification.
 - c. Rotate the knob to select **Master** and press **[Enter]** key to confirm.
 - d. Set **Master group** to A and press **[Enter]** key to confirm.
 - e. Set **Master Total** to 3 and press **[Enter]** key to confirm.
4. Configure the remaining two power supplies as slave units.
 - a. Press **[Shift]+[Save]** (System) to enter into the system menu interface.
 - b. Use left and right keys or rotate the knob to select **Parallel** and press **[Enter]** key to make the parameter in modification.
 - c. Rotate the knob to select **Slave** and press **[Enter]** key to confirm.
 - d. Set **Slave group** to A and press **[Enter]** key to confirm.

- After making the master-slave setting, the instrument will automatically restart to ensure normal operation.

Configure Three Groups

Take seven power supplies for instance, set them to three groups. Group A: one master unit and two slave units. Group B / C: one master unit and one slave unit. The detailed connection method and procedures are as follows.

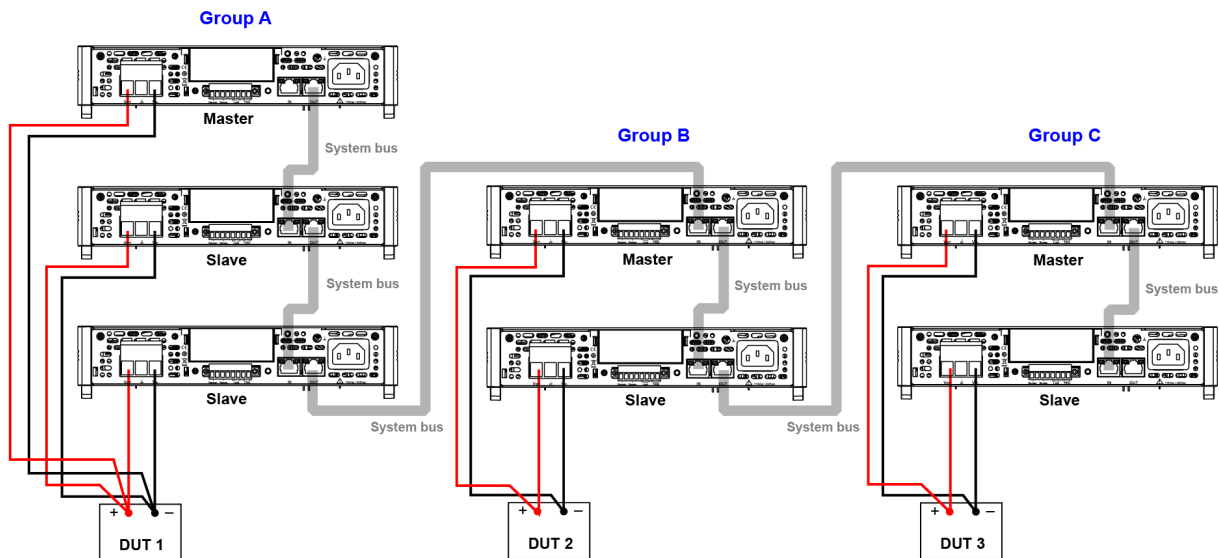

Note

The rear panel shown in the figure is only an example. The actual appearance of the rear panel is subject to the specific instrument.

- Configure the channel number of each instrument. Please refer to [4.3.1 Multi-Channel Function](#) for detailed introduction.
- Connect the instruments according to the above diagram.
 - Connect system bus interfaces. Before connecting the system bus, be sure that the instrument is single mode.
 - Connect the DUTs. Refer to [2.6 Connecting the Device Under Test \(DUT\)](#) for more information about connection methods.
- After finishing connection, configure one power supply as a master unit.
 - Press **[Shift]+[Save]** (System) to enter into the system menu interface.
 - Use left and right keys or rotate the knob to select **Parallel** and press **[Enter]** key to make the parameter in modification.
 - Rotate the knob to select **Master** and press **[Enter]** key to confirm.
 - Set **Master group** to A and press **[Enter]** key to confirm.
 - Set **Master Total** to 3 and press **[Enter]** key to confirm.
 - Repeat steps a through e for the other two master units. Set **Master group** to B and C. Set **Master Total** to 2 and 2.

4. Configure other power supplies as slave units.
 - a. Press **[Shift]+[Save]** (System) to enter into the system menu interface.
 - b. Use left and right keys or rotate the knob to select **Parallel** and press **[Enter]** key to make the parameter in modification.
 - c. Rotate the knob to select **Slave** and press **[Enter]** key to confirm.
 - d. Set **Slave group** to A and press **[Enter]** key to confirm.
 - e. Repeat steps a through d for the other slave units. Set **Slave group** to B and C.
5. After making the master-slave setting, the instrument will automatically re-start to ensure normal operation.

To change Parallel Mode to Single Mode, follow the steps below:

1. Power off the power supplies.
2. Remove System Bus among the power supplies.
3. Power on the power supplies.
4. Switch the power supplies into single mode respectively.
 - a. Press **[Shift]+[Save]** (System) to enter into the system menu interface.
 - b. Use left and right keys or rotate the knob to select **Parallel** and press **[Enter]** key to make the parameter in modification.
 - c. Rotate the knob to select **Single** and press **[Enter]** key to confirm.

4.3.3 Synchronized Function (Link)

The user can set synchronized operation mode among multiple power supplies connected via the system bus. There are the following two synchronized status.

- **Online:** indicates the instrument is in the synchronized relationship. At this time, the front panel **[Link]** key light is lit.
- **Offline:** indicates the instrument is not in the synchronized relationship and the front panel **[Link]** key light is off.

The user can select the following three synchronized modes.

- **On/Off Only:** set multiple units to output on/off and Save/Recall synchronization.
- **Track:** besides output on/off and Save/Recall synchronization, you can set the voltage proportional relation **Reference** among multiple power supplies to make the voltage change proportionally. For example, set the voltage proportional relation for three power supplies to 3, 4 and 5. If the voltage of the first power supply is set to 30 V, the voltage of the other two power supplies will change to 40 V and 50 V automatically.

Note

In the **Track** mode, the Save/Recall synchronization is only effective for the current setting value, and the voltage setting value is controlled by the **Reference**.

- **Duplicate**: in this mode, the synchronized operations includes: output on/off synchronization, voltage/current setting value changing synchronization, Save/Recall synchronization, priority mode synchronization, voltage/current rising/falling synchronization and Protect menu function synchronization.

CAUTION

Unlike the On/Off Only and Track modes, synchronization in the Duplicate mode must involve the same model.

Note

For multiple devices that have formed a synchronization relationship, after the mode is set to **Duplicate**, long press (about 3 s) the **Link** button of any device to quickly synchronize the voltage/current setting value, priority mode, voltage/current rise/fall value, and Protect settings to other devices.

Setting method:

You can enter into the system menu to set the status(Online/Offline) of the instrument, or you can short press (1 s or so) the front panel **[Link]** key to switch the synchronization status of the instrument. Long pressing (about 3 s) **[Link]** key can display the current synchronization status of the instrument. At this time, pressing **[Enter]** key can enter into the synchronization menu setting interface. You can set parameters such as synchronized mode or On/Off delay time.

Note

In the synchronized status, you can set the On/Off delay time of each instrument to customize your test timing.

Take the synchronized relationship among single power supply and multiple parallel groups for instance, the detailed connection method and procedures are as follows.

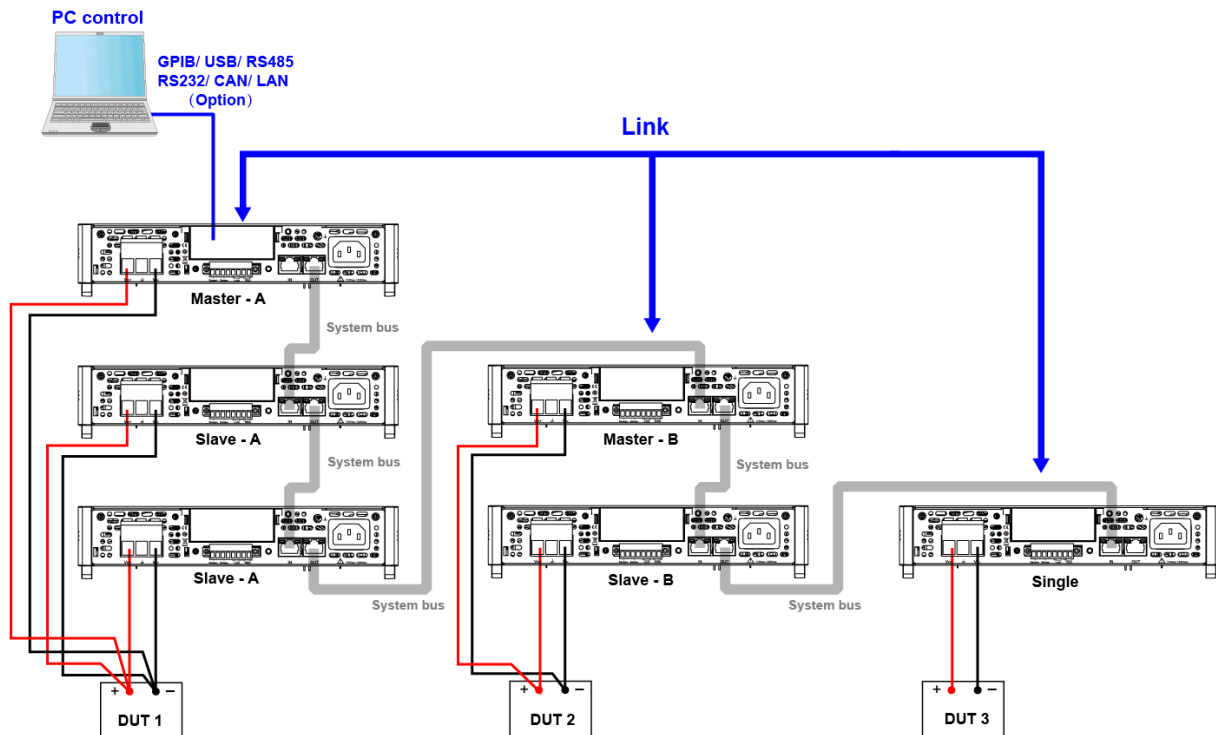

Note

The rear panel shown in the figure is only an example. The actual appearance of the rear panel is subject to the specific instrument.

1. Configure the channel number of each instrument. Please refer to [4.3.1 Multi-Channel Function](#) for detailed introduction.
2. Connect the instruments according to the above diagram.
 - a. Connect system bus interfaces.
 - b. Connect the DUTs. Refer to [2.6 Connecting the Device Under Test \(DUT\)](#) for more information about connection methods.
3. Turn on the **Link** switch of each instrument in turns.



Note

In a parallel group, you only need to turn on the master's Link switch.

- a. Press **[Shift]+[Save]** (System) to enter into the system menu interface.
- b. Use left and right keys or rotate the knob to select **Link** and press **[Enter]** key to make the parameter in modification.
- c. Rotate the knob to set **Status** and press **[Enter]** key to confirm.
 - **Online**: indicates the instrument is in the synchronized relationship.

- **Offline:** indicates the instrument is not in the synchronized relationship.
4. Operate the front panel of one unit in the System Bus link and set the synchronization mode (other units modes will be modified simultaneously).
 - a. Press **[Shift]+[Save]** (System) to enter into the system menu interface.
 - b. Use left and right keys or rotate the knob to select **Link** and press **[Enter]** key to make the parameter in modification.
 - c. Rotate the knob to set **Mode** and press **[Enter]** key to confirm.
 - **OnOff Only**
 - **Track→Reference**



Note

If you select **Track** mode, you need to set the **Reference** value of each unit in the System Bus link.

- **Duplicate**

4.4 Protection Function

This series power supplies provide the following protection functions. You can set these functions in the Protect menu.

- The maximum output voltage setting value (U-Max), the minimum output voltage setting value (U-Min) and the maximum output power value (P-Max), these functions limit the setting value of the output voltage and current from front panel.
- Over-voltage protection, over-current protection, over-power protection, under-voltage protection, under-current protection, foldback protection and over-temperature protection, these functions disable the output to protect the device under test (DUT), as well as the power supply.

4.4.1 Set the Setting Value Limit Protection

To avoid causing damage to the DUT, after you set the U-Max, U-Min and P-Max, the setting value from the **[V-set]** or **[I-set]** key on the front panel can't exceed the setting limit.

The operation steps are as follows.

1. Press **[Shift]+[Recall]** (Protect) to enter Protect menu interface.

2. Use left and right keys or rotate the knob to select **U-Max**, **U-Min** or **P-Max** and press **[Enter]** key to confirm.
3. Rotate the knob to adjust the value and press **[Enter]** key to confirm.
4. Press **[Esc]** to exit the protection menu setting.

4.4.2 Set Over-Voltage Protection

Over-voltage protection function allows the user to enable the protection and set a over-voltage limit (**Level**) and delay time (**Delay**). This function prevents the output voltage from being higher than the limited output voltage and protects the connected DUT so it this is not over-voltage and possibly damaged due to an excessive voltage.

An over-voltage protection will occur if:

- Enable OVP;
- The output voltage value is greater than the set voltage protection point **Level** and the period is greater than the set protection delay time **Delay**.

Delay time Delay — You can specify an OVP delay to prevent momentary output settings, DUT and status changes from tripping the over-voltage protection. In most cases these momentary conditions would not be considered an over-voltage protection fault, and having an OVP condition disable the output when they occur would be a nuisance. Specifying an OVP delay lets the OVP circuit ignore these momentary changes during the specified delay period. Once the OVP delay time has expired and the over-voltage condition persists, the output will shut down.

When over-voltage protection occurs, the instrument responds as follows:

- Instrument output is off;
- The buzzer sounds;
- The interface displays “Over Voltage Protect” and flashes;
- Status register, the OV status bit is set to 1.

Enable OVP

1. Press **[Shift]+[Recall]** (Protect) to enter Protect menu interface.
2. Use left and right keys or rotate the knob to select **OVP** and press **[Enter]** key to confirm.
3. Use left and right keys or rotate the knob to select **On** and press **[Enter]** key to confirm.
4. Rotate the knob to adjust the over-voltage limit **Level** and press **[Enter]** key to confirm.
5. Rotate the knob to adjust the delay time **Delay** and press **[Enter]** key to confirm.

6. Press **[Esc]** to exit the protection menu setting.

Clear Over-Voltage Protection

To clear the over-voltage and return to normal operation, firstly remove the conditions that caused the protection fault. Press **[Esc]** key (or send the command **PROtection:CLEar**) to clear the protection status. The “Over Voltage Protect” displayed in front panel is cleared and the instrument exits OVP status.

4.4.3 Set Over-Current Protection

Over-current protection function allows the user to enable the protection and set a over-current limit (**Level**) and delay time (**Delay**). This function prevents the output current from being higher than the limited output current and protects the connected DUT so it this is not over-current and possibly damaged due to an excessive current.

An over-current protection will occur if:

- Enable OCP;
- The output current value is greater than the set current protection point **Level** and the period is greater than the set protection delay time **Delay**.

Delay time **Delay** — You can specify an OCP delay to prevent momentary output settings, DUT and status changes from tripping the over-current protection. In most cases these momentary conditions would not be considered an over-current protection fault, and having an OCP condition disable the output when they occur would be a nuisance. Specifying an OCP delay lets the OCP circuit ignore these momentary changes during the specified delay period. Once the OCP delay time has expired and the over-current condition persists, the output will shut down.

When over-current protection occurs, the instrument responds as follows:

- Instrument output is off;
- The buzzer sounds intermittently;
- The interface displays “Over Current Protect” and flashes;
- Status register, the OC status bit is set to 1.

Enable OCP

1. Press **[Shift]+[Recall]** (Protect) to enter Protect menu interface.
2. Use left and right keys or rotate the knob to select **OCP** and press **[Enter]** key to confirm.
3. Use left and right keys or rotate the knob to select **On** and press **[Enter]** key to confirm.

4. Rotate the knob to adjust the over-current limit **Level** and press **[Enter]** key to confirm.
5. Rotate the knob to adjust the delay time **Delay** and press **[Enter]** key to confirm.
6. Press **[Esc]** to exit the protection menu setting.

Clear Over-Current Protection

To clear the over-current and return to normal operation, firstly remove the conditions that caused the protection fault. Press **[Esc]** key (or send the command **PROtection:CLEar**) to clear the protection status. The “Over Current Protect” displayed in front panel is cleared and the instrument exits OCP status.

4.4.4 Set Over-Power Protection

Over-power protection function allows the user to enable the protection and set a over-power limit (**Level**) and delay time (**Delay**). This function prevents the output power from being higher than the limited output power and protects the connected DUT so it this is not over-power and possibly damaged due to an excessive power.

An over-power protection will occur if:

- Enable OPP;
- The output power value is greater than the set power protection point **Level** and the period is greater than the set protection delay time **Delay**.

Delay time **Delay** — You can specify an OPP delay to prevent momentary output settings, DUT and status changes from tripping the over-power protection. In most cases these momentary conditions would not be considered an over-power protection fault, and having an OPP condition disable the output when they occur would be a nuisance. Specifying an OPP delay lets the OPP circuit ignore these momentary changes during the specified delay period. Once the OPP delay time has expired and the over-power condition persists, the output will shut down.

When over-power protection occurs, the instrument responds as follows:

- Instrument output is off;
- The buzzer sounds intermittently;
- The interface displays “Over Power Protect” and flashes;
- Status register, the OP status bit is set to 1.

Enable OPP

1. Press **[Shift]+[Recall]** (Protect) to enter Protect menu interface.
2. Use left and right keys or rotate the knob to select **OPP** and press **[Enter]** key to confirm.
3. Use left and right keys or rotate the knob to select **On** and press **[Enter]** key to confirm.
4. Rotate the knob to adjust the over-power limit **Level** and press **[Enter]** key to confirm.
5. Rotate the knob to adjust the delay time **Delay** and press **[Enter]** key to confirm.
6. Press **[Esc]** to exit the protection menu setting.

Clear Over-Power Protection

To clear the over-power and return to normal operation, firstly remove the conditions that caused the protection fault. Press **[Esc]** key (or send the command **PROtection:CLEar**) to clear the protection status. The “Over Power Protect” displayed in front panel is cleared and the instrument exits OPP status.

4.4.5 Set Under-Voltage Protection

Under-voltage protection function allows the user to enable the protection and set a under-voltage limit (**Level**), delay time (**Delay**) and warm-up time (**Warm Up**).

An under-voltage protection will occur if:

- Enable UVP;
- The output time exceeds the warm-up time;

Warm-up time **Warm Up** — You can specify the warm-up time for UVP protection to make the instrument not judge the under-voltage protection fault within the specified warm-up time.

- The output voltage value is less than the set voltage protection point **Level** and the period is greater than the set protection delay time **Delay**.

Delay time **Delay** — You can specify an UVP delay to prevent momentary output settings, DUT and status changes from tripping the under-voltage protection. In most cases these momentary conditions would not be considered an under-voltage protection fault, and having an UVP condition disable the output when they occur would be a nuisance. Specifying an UVP delay lets the UVP circuit ignore these momentary changes during the specified delay period. Once the UVP delay time has expired and the under-voltage condition persists, the output will shut down.

When under-voltage protection occurs, the instrument responds as follows:

- Instrument output is off;
- The buzzer sounds intermittently;
- The interface displays “Under Voltage Protect” and flashes;
- Status register, the UV status bit is set to 1.

Enable UVP

1. Press **[Shift]+[Recall]** (Protect) to enter Protect menu interface.
2. Use left and right keys or rotate the knob to select **UVP** and press **[Enter]** key to confirm.
3. Use left and right keys or rotate the knob to select **On** and press **[Enter]** key to confirm.
4. Rotate the knob to adjust the under-voltage limit **Level** and press **[Enter]** key to confirm.
5. Rotate the knob to adjust the delay time **Delay** and press **[Enter]** key to confirm.
6. Rotate the knob to adjust the warm-up time **Warm Up** and press **[Enter]** key to confirm.
7. Press **[Esc]** to exit the protection menu setting.

Clear Under-Voltage Protection

To clear the under-voltage and return to normal operation, firstly remove the conditions that caused the protection fault. Press **[Esc]** key (or send the command **PROtection:CLEar**) to clear the protection status. The “Under Voltage Protect” displayed in front panel is cleared and the instrument exits UVP status.

4.4.6 Set Under-Current Protection

Under-current protection function allows the user to enable the protection and set a under-current limit (**Level**), delay time (**Delay**) and warm-up time (**Warm Up**).

An under-current protection will occur if:

- Enable UCP;
- The output time exceeds the warm-up time;

Warm-up time **Warm Up** — You can specify the warm-up time for UCP protection to make the instrument not judge the under-current protection fault within the specified warm-up time.

- The output current value is less than the set current protection point **Level** and the period is greater than the set protection delay time **Delay**.

Delay time **Delay** — You can specify an UCP delay to prevent momentary output settings, DUT and status changes from tripping the under-current protection. In most cases these momentary conditions would not be considered an under-current protection fault, and having an UCP condition disable the output when they occur would be a nuisance. Specifying an UCP delay lets the UCP circuit ignore these momentary changes during the specified delay period. Once the UCP delay time has expired and the under-current condition persists, the output will shut down.

When under-current protection occurs, the instrument responds as follows:

- Instrument output is off;
- The buzzer sounds intermittently;
- The interface displays “Under Current Protect” and flashes;
- Status register, the UC status bit is set to 1.

Enable UCP

1. Press **[Shift]+[Recall]** (Protect) to enter Protect menu interface.
2. Use left and right keys or rotate the knob to select **UCP** and press **[Enter]** key to confirm.
3. Use left and right keys or rotate the knob to select **On** and press **[Enter]** key to confirm.
4. Rotate the knob to adjust the under-current limit **Level** and press **[Enter]** key to confirm.
5. Rotate the knob to adjust the delay time **Delay** and press **[Enter]** key to confirm.
6. Rotate the knob to adjust the warm-up time **Warm Up** and press **[Enter]** key to confirm.
7. Press **[Esc]** to exit the protection menu setting.

Clear Under-Current Protection

To clear the under-current and return to normal operation, firstly remove the conditions that caused the protection fault. Press **[Esc]** key (or send the command **PROtection:CLEar**) to clear the protection status. The “Under Current Protect” displayed in front panel is cleared and the instrument exits UCP status.

4.4.7 Over-Temperature Protection

To prevent damaging heat build-up and ensure specified performance, make sure there is adequate ventilation and air flow around the instrument to ensure proper cooling. Do not cover the ventilation holes on the top, sides, or bottom of the instrument.

Even with proper ventilation, the instrument can overheat in the following situations

- If the ambient temperature is too high;
- If you use the instrument to test for long periods.

Over-temperature protection is a protective measure implemented when the internal temperature of the instrument exceeds 85 degrees. Once the over-temperature protection has been triggered, the output will shut down and VFD shows “Over Temp Prot”.

If an over-temperature condition occurs, turn off the instrument and allow it to cool for 30 minutes. You cannot turn the output on until the instrument cools down. Press **[On/Off]** key to turn the output on.

CAUTION

When you return power to the instrument, verify that the cooling fan is running. If not, please contact ITECH. Leaving the instrument turned on with the failure message displayed or with an inoperative cooling fan may result in damage to the instrument.

4.4.8 Set foldback protection

This series of instruments has a Foldback protection function, which is used to turn off the output when the power supply CV / CC is switched, so as to protect certain DUTs that are sensitive to voltage overshoot and current overshoot. Foldback protection allows the user to specify a working mode and set the protection delay time. If the current working mode is switched, the protection will be triggered from the working loop switch. When the delay time is exhausted, the protection will be triggered and the output will be turned off.

- Enable FOLDBACK function;
- The loop is switched to the set working mode and the duration is greater than the set protection delay time;

Enable FOLDBACK function

1. Press **[Shift]+[Recall]** (Protect) to enter Protect menu interface.
2. Use left and right keys or rotate the knob to select **FOLDBACK** and press **[Enter]** key to confirm.
3. Select **CC** or **CV** and press **[Enter]** key to confirm.
 - Selecting CC means that the instrument triggers protection when the operating mode of the instrument switches to CC mode.

- Selecting CV means that the instrument triggers protection when the operating mode of the instrument is switched to CV mode.
 - Select OFF to turn off the foldback function.
4. Rotate the knob to adjust the **Delay** and press **[Enter]** key to confirm.
 5. Press **[Esc]** to exit the protection menu setting.

Delay FOLDBACK

You can specify a time for the FOLDBACK delay, which can make the instrument ignore the instantaneous change of the operating mode in the specified delay interval. In most cases, this instantaneous situation is not considered as a switching state, and there is no need to trigger the foldback function and disable Output. Once the FOLDBACK delay time is exceeded, the output is turned off.

4.5 List Function

The user can use list function to create a test program made of multiple steps. Up to 10 programs (List1 to List10) can be created in the list mode for this series power supplies. Each list program can be made of up to 100 steps. The user need to set voltage or current, slope and dwell time for each step. The user also can set repeat times, end state and so on for each list program. The descriptions of list function menu are listed in the table below.

List Mode	List mode			
	Run List	Turn the list mode on/off.		
		On	Turn the list mode on.	
		Off	Turn the list mode off.	
	Recall List	Select a list program to view.		
		List Setup	View the setting parameters of the selected list program.	
		View Step	Select the desired step to view.	
	Edit List	Edit list program.		
		List Setup	Set the list program.	
			Mode	Set the operation mode for list program. <ul style="list-style-type: none"> • CC: current mode; • CV: voltage mode.
			End State	Set the running state after the list program is running over.

				<ul style="list-style-type: none"> • Normal: keep outputting the voltage and current setting in main interface when the dwell time is over. • Last: keep outputting the last step when the dwell time is over.
			Repeat	Set the number of list repetitions within the range from 1 to 65535. Set to 65535 to run in an infinite loop.
		Edit Step	Edit parameters for each step.	
			Current/ Voltage	Current value or voltage value. (The voltage appears when CV mode is selected; the current appears when CC mode is selected.)
			Slope	Slope value.
			Time	Duration (0.001~3600), unit: second.
			Next	Select whether to edit the next step: <ul style="list-style-type: none"> • Yes • No
		Insert Step	Insert steps before each specified step.	
		Add Step	Add steps after each specified step.	
		Delete Step	Delete the selected step.	
		Delete all	Delete all steps.	
		Copy File X to X	Copy list program.	

4.5.1 Edit List Program

You can use the list program to perform a variety of output waveform simulations. The execution flowchart of list program is as follows.

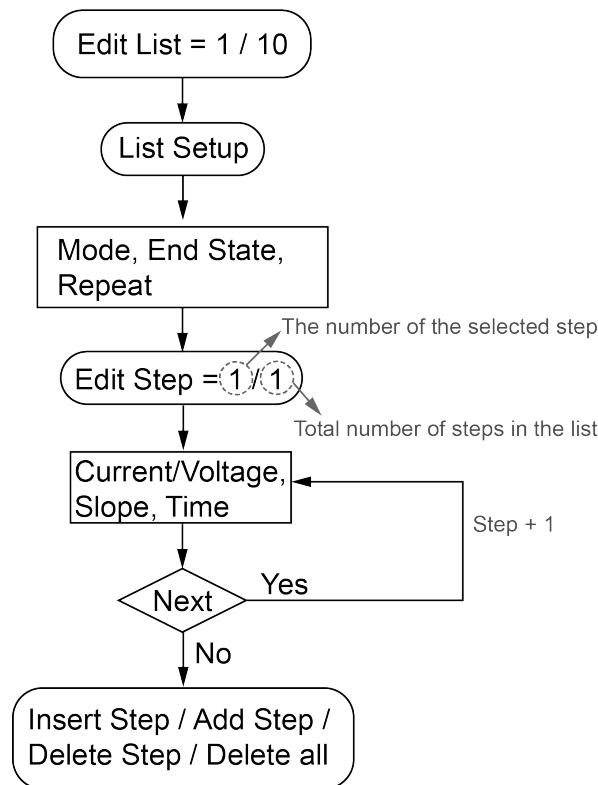

The detailed operation steps are as follows.

1. Press **[Shift]+[I-set]** (Function) to enter function menu interface.
2. Use left and right keys or rotate the knob to select **List** and press **[Enter]** key to confirm.
3. Use left and right keys or rotate the knob to select **Edit List** and press **[Enter]** key to confirm.
4. Use knob to set the list name and press **[Enter]** key to confirm.
5. Use left and right keys or rotate the knob to select **List Setup** and press **[Enter]** key to confirm.
 - a. Select **Mode** to set list mode: CC/ CV.
 - b. Select **End State** to set running state after the list program is running over.
 - Normal: keep outputting the voltage and current setting in main interface when the dwell time is over.
 - Last: keep outputting the last step when the dwell time is over.
 - c. Select **Repeat** to set the number of list repetitions.
6. Select **Edit Step** and press **[Enter]** key to confirm.
7. Use knob to set the desired list step number and press **[Enter]** key to confirm.

To the left of the slash is the desired step number to be edited and to the right of the slash is the total steps number of the list program. The total number of steps changes by the addition of the number of steps in the editing process.

- a. Select **Current** or **Voltage** to set the current or voltage value.
 - b. Select **Slope** to set the slope of the step.
 - c. Select **Time** to set the dwell time of the step.
 - d. Select **Next** to set whether to edit the next step. If set to **Yes**, repeat steps a through c to set the parameters for next step. If set to **No**, the list step parameters setting is over.
8. If you need to continue to adjust the list step, you can use the following settings to insert, add or delete steps.
- If you need to insert steps, select **Insert Step** and press **[Enter]** key to confirm. Use knob to set the insert location and press **[Enter]** key. Repeat steps 7a through 7d to set the parameters for the inserted step. The inserted step is before each specified step and you can insert multiple steps continuously.
 - If you need to add steps, select **Add Step** and press **[Enter]** key to confirm. Use knob to set the add location and press **[Enter]** key. Repeat steps 7a through 7d to set the parameters for the added step. The added step is after each specified step and you can add multiple steps continuously.
 - If you need to delete steps, select **Delete Step** and press **[Enter]** key to confirm. Use knob to set the delete location and press **[Enter]** key.
 - If you need to delete all steps, select **Delete all** and press **[Enter]** key to confirm. Use knob to select **Yes** and press **[Enter]** key.

4.5.2 Copy List Program

For an existed list program, you can copy and name it a new list program. Then you can edit the new list program, insert steps or delete steps. This function simplifies the edit operation for similar list program. The operation steps are as follows.

1. Press **[Shift]+[I-set]** (Function) to enter function menu interface.
2. Use left and right keys or rotate the knob to select **List** and press **[Enter]** key to confirm.
3. Use left and right keys or rotate the knob to select **Edit List** and press **[Enter]** key to confirm.
4. Use knob to set the list program name and press **[Enter]** key to confirm.
5. Select **Copy File X to X** and press **[Enter]** key to confirm.
6. Use knob to select setting source List program name and target List program name and press **[Enter]** key to confirm.

4.5.3 View List Program

Before selecting and running the list program, you can view the related parameters and each step of the existed list program. The operation steps to view the list program are as follows.

1. Press **[Shift]+[I-set]** (Function) to enter function menu interface.
2. Use left and right keys or rotate the knob to select **List** and press **[Enter]** key to confirm.
3. Use left and right keys or rotate the knob to select **Recall List** and press **[Enter]** key to confirm.
4. Use knob to select the list program to view and press **[Enter]** key to confirm.
5. Select **List Setup** and press **[Enter]** key to enter the view page of list file. Use left and right keys or rotate the knob to view the following parameters.
 - Mode: the operation mode for list program.
 - End State: the running state after the list program is running over.
 - Repeat: the number of list repetitions.
6. Select **View Step** and press **[Enter]** key to confirm.
7. Use knob to select the list step to view and press **[Enter]** key to confirm.

To the left of the slash is the desired step number to view and to the right of the slash is the total steps number of the list program. At this point, the interface displays all steps and automatically locates at the selected step.
8. Use knob or left and right keys to view all steps.

4.5.4 Run List Program

The user can run the existed list program as needed to enable outputting of corresponding waveform sequence by the power supply. Detailed operation steps are as below:

1. Press **[Shift]+[I-set]** (Function) to enter function menu interface.
2. Use left and right keys or rotate the knob to select **List** and press **[Enter]** key to enter the set interface of list mode.
3. Select the desired list program.
 - Method 1: Select **Recall List** and press **[Enter]** key. Use knob to select the desired list program and press **[Enter]** key to confirm.
 - Method 2: To simplify the operation, you can directly run the list program after editing it in the **Edit List** menu item. Skip the step in the **Recall List** menu item.
4. Select **Run List** and press **[Enter]** key to confirm.
5. Use the knob to set **Run List** to **On** and press **[Enter]** key to confirm.
6. Press **[On/Off]** key to turn the output on.
7. Based on the trigger method, perform the trigger operation. When the trigger signal is received, the power supply outputs the waveform sequences.

Stop running: During the running of List, you can press **[Shift]+[I-set]** (Function) to enter the Function menu and set the **Run List** as **Off** to stop running. Otherwise, the List waveform cannot be edited while the List is running.

4.6 Battery Charging Test Function

This series provide battery function used to test the battery charging. The user can set four cut off conditions: cut off voltage, cut off current, current off capacity and the charging time. If anyone of the four conditions are satisfied, the test will be interrupted automatically. During test, the user can observe voltage, charging time and charged capacity of battery.

Press **[Shift]+[I-set]** (Function) to enter function menu interface. Use left and right keys or rotate the knob to select **Battery** and press **[Enter]** key to enter into the battery charging test setting interface.

Battery	Battery charging test function	
	Run Battery	Turn the battery charging test function on
	Charge V	Set the charging voltage.
	Charge I	Set the charging current.
	Charge Time	Set the charging time.
	Cut Off V	Set the cut off voltage.
	Cut Off I	Set the cut off current.
	Cut Off Q	Set the cut off capacity.
	Circle	Set the cycle charging mode. <ul style="list-style-type: none"> • Off: Turn off cycle charging. • On: Turn on cycle charging. After turning on the cycle charging mode, you also need to set the Voltage parameter to indicate that charging restarts when the battery voltage is lower than the cycle voltage set here.

The operation steps to set the battery charging test function are as follows.

1. Before using the battery charging test function, the user need to turn the bleeder function off.
 - a. Press **[Shift]+[Save]** (System) to enter into the system menu interface.
 - b. Use knob or left and right keys to select **Bleeder**, press **[Enter]** to confirm.

- c. Use knob or left and right keys to select **Off** to turn the Pw mode off. Press **[Enter]** to confirm.
- d. Press **[Esc]** to exit the system menu interface.
2. Set the power supply output voltage value and current value according to the battery specifications to be tested.
3. Press **[Shift]+[I-set]** (Function) to enter function menu interface.
4. Use left and right keys or rotate the knob to select **Battery** and press **[Enter]** key to confirm.
5. Use knob to adjust the following battery test parameters and press **[Enter]** key to confirm.
 - 2 : Charge V
 - 3 : Charge I
 - 4 : Charge Time
 - 5 : Cut off V
 - 6 : Cut off I
 - 7 : Cut Off Q
 - 8 : Circle
6. Use left and right keys or rotate the knob to select **Run Battery** and press **[Enter]** key to confirm.
7. Rotate the knob to change **Off** to **On** and press **[Enter]** key to confirm.
8. Press **[On/Off]** key to turn the output on and the power supply outputs the battery charging test.

4.7 External Analog Function (Option)

This menu item is used to control the external analog function to enable or disable. The external analog interface is not the standard-equipped interface for the power supply.

This series power supply provides a optional DB-25 analog interface(IT-E1208). The analog interface provides the following capability:

- Remote control of output voltage and current
- Remote control of output On/Off state
- Remote monitoring of output voltage/current measurement and CC/CV mode
- Remote monitoring of output On/Off state, load status and fault status
- Clear the instrument malfunction
- RS-485 communication interface, please refer to [2.7.6 RS-485 Interface](#) for detailed description about the interface

Analog signal bandwidth is less than 100 Hz, supports any waveform within signal bandwidth. When the program signal frequency or amplitude exceeds output capacity, the output amplitude will be automatically limited.

The definitions and descriptions for analog interface are as follows.

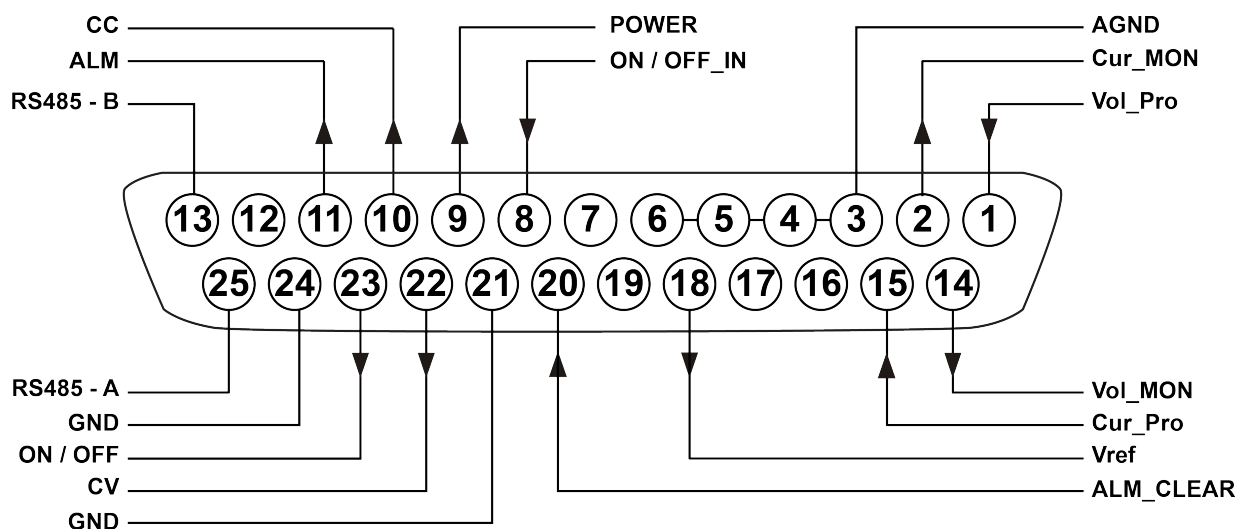

Pin	Name	Type	Description
1	Vol_Pro	Analog in	Programs output voltage. Use an input voltage in the range of 0 V to 10 V to control the output voltage in the range of 0 % to 100 %.
2	Cur_MON	Analog out	Current monitor signal. This pin generates a voltage of 0 V to 10 V to monitor an output current of 0 V to the maximum rated value. For example, if the maximum rated value is 60 A, and if the pin generates 2 V, the output voltage should be approximately 12 A
3/4/5/6	AGND	Ground	Ground for analog inputs and outputs.
7	-	-	Not used
8	ON / OFF_IN	Digital in	Receives the signal that is used to turn the output on or off. If a 0 V signal is applied, the output is turned off. If a 5 V signal is applied, the output is turned on.
9	Power	Digital out	Sends the signal that is used to indicate whether the output status is normal or not. If the power supply outputs normally, the pin generates 5 V. If the power supply malfunctions, the pin generates 0 V.
10	CC	Digital out	Sends the signal that is used to indicate the operation mode of the power supply. When the power supply is in CC mode, the pin generates 5 V. When the power supply is in CV mode, the pin generates 0 V.
11	ALM	Digital out	Sends the signal that is used to indicate whether the power supply malfunctions or not. When the power supply operates well, the pin generates 5 V. When the power supply has a malfunction, the pin generates 0 V.
12	-	-	Not used

Pin	Name	Type	Description
13, 25	RS485-B RS485-A	Communi- cation interfaces	RS485 communication interfaces.
14	Vol_MON	Analog out	Voltage monitor signal. This pin generates a voltage of 0 V to 10 V to monitor an output voltage of 0 V to the maximum rated value. For example, if the maximum rated value is 80 V, and if the pin generates 2.5 V, the output voltage should be approximately 20 V
15	Cur_Pro	Analog in	Programs output current. Use an input voltage in the range of 0 V to 10 V to control the output current in the range of 0 % to 100 %.
16/17/ 19	–	–	Not used
18	Vref	Analog out	Signal output for external resistance control of the DC signal (produced by the internal signal source). Approximately 10 V. Connected to the external resistor.
20	ALM_ CLEAR	Digital in	Signal input for clearing the instrument malfunction. If a 0 V signal is applied, the malfunction will not be cleared. If a 5 V signal is applied, the malfunction will be cleared.
21	GND	Ground	Ground for digital inputs and outputs.
22	CV	Digital out	Signal output for indicating the operation mode of the power supply. When the power supply is in CV mode, the pin generates 5 V; If the power supply is in CC mode, the pin generates 0 V.
23	ON / OFF	Digital out	Signal output for indicating the output On/Off status of the power supply. When the output is turned on, the pin generates 5 V; If the output is turned off, the pin generates 0 V.
24	GND	Ground	Ground for digital inputs and outputs.

CAUTION

- **Before connecting the hardware device that controls the analog interface, make sure that the hardware device does not output a voltage higher than 20% of the specified value to the pin, otherwise the instrument will be damaged. For example, when setting the voltage or current, the input voltage can't exceed 12V, otherwise the instrument will be damaged.**
- **In analog remote control mode, the analog signal input pin cannot be left floating. Before enabling the external analog function, verify that pin 1 (Vol_Pro) and pin 15 (Cur_Pro) are connected correctly. If the set value does not need to be adjusted, it can be fixed to a defined level, or directly connected to pin 18 (Vref), and the set value is directly set to the maximum rated value.**
- **Safe electrical isolation is set between this analog interface and output electrode. Do not connect any ground wire of the analog interface to the positive and negative terminals of the output interface.**

Enable/Disable Analog Control

To run this function, the power supply must be in the control of external analog control mode. The operation steps to set this menu item are as follows.

1. Press **[Shift]+[Save]** (System) keys to enter into the system menu.
2. Use left and right keys or rotate the knob to select **Comm** and press **[Enter]**.
3. Use left and right keys or rotate the knob to select **Ext-program** and press **[Enter]**.

Note

This menu is only displayed if the user has installed the analog interface. If there is no analog interface, this menu item is not displayed.

4. Rotate the knob to adjust the value.
 - Off: default value, indicates disable this function.
 - On: indicates enable this function. Before enabling the external analog function, verify that pin 1 (Vol_Pro) and pin 15 (Cur_Pro) are connected correctly.
5. After finishing the setting, press **[Enter]** key to confirm.

Remote Control Using the Analog Interface

Different functions can be realized by different pins. The following examples of common voltage and current settings and voltage and current monitoring are used to explain how to wire and how to use them.

When controlling voltage and current settings via the analog interface, the rated output voltage or current can be controlled in the range of 0 % to 100 % using an input voltage in the range of 0 V to 10 V; Or the output voltage or current can be monitored in the range of 0 % to 100 % by the output voltage in the range of 0 V to 10 V. In parallel operation, you can program or monitor output through the master analog interface. The programing and monitoring range is changed to 0 % to 100 % range of parallel machine.

- Voltage Setting and Current Setting

This function can remotely change the voltage and current settings by sending an external analog signal.

- Voltage setting: Analog control of the output voltage can be accomplished by connecting external DC voltage sources in the range of 0 V to 10 V to the 1(Vol_Pro) and 3(AGND) pins.
- Current setting: Analog control of the output current can be accomplished by connecting external DC voltage sources in the range of 0 V to 10 V to the 15(Cur_Pro) and 4(AGND) pins.



Note

Before enabling the external analog function, verify that pin 1 (Vol_Pro) and pin 15 (Cur_Pro) are connected correctly.

The connection diagram is as follows:

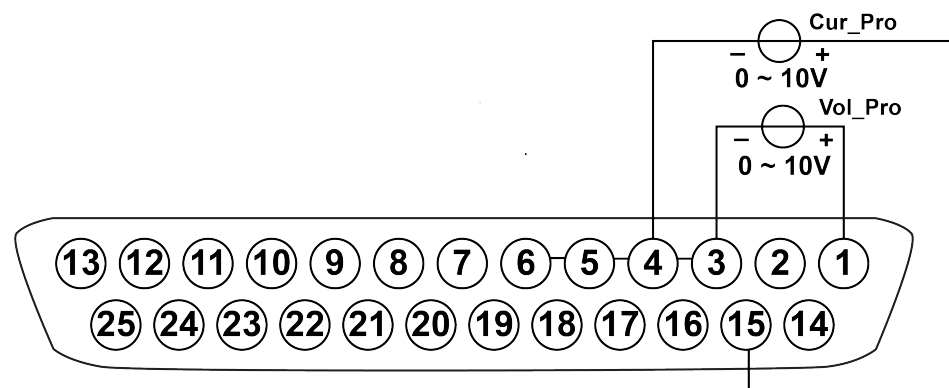

By connecting a voltage source to the Vol_Pro or Cur_Pro pins, a voltage setting from 0 to + 10 V corresponds to the zero to full-scale voltage or current setting of the power supply. For example, if the maximum rated value is 120 V, and if the voltage source is set to 5 V, the setting voltage should be approximately 60 V. If the maximum rated value is 30 A, and if the voltage source is set to 5 V, the setting current should be approximately 15 A.

- Voltage Monitoring and Current Monitoring

This function can monitor and read the output voltage and current values.

- Voltage monitoring: Output voltage values can be monitored and read by connecting a digital voltmeter to the 14(Vol_MON) and 5(AGND) pins.
- Current monitoring: Output current values can be monitored and read by connecting a digital voltmeter to the 2(Cur_MON) and 6(AGND) pins.

The connection diagram is as follows:

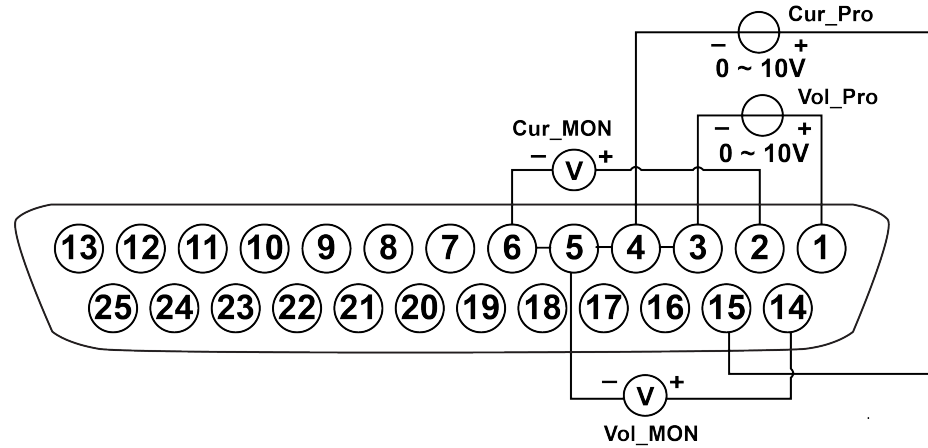

By connecting a digital voltmeter to the Vol_MON or Cur_MON pins, a voltage reading from 0 to + 10 V corresponds to the zero to full-scale voltage or current output of the power supply. For example, if the maximum rated value is 120 V, and if the pin 14 generates 2.5 V, the output voltage should be approximately 30 V. If the maximum rated value is 30 A, and if the pin 2 generates 2 V, the output current should be approximately 6 A.

5 Specification

This chapter will introduce the rated voltage, current, power and many other main parameters of IT-M3100 series power supplies.

- ◆ Main Specification
- ◆ Supplemental Characteristics

5.1 Main Specification

5.1.1 IT-M3110

Parameter		IT-M3110
Rated value (0 °C-40 °C)	Voltage	0~20V
	Current	0~100A
	Power	400W
Load Regulation	Voltage	≤0.01%+30mV
±(% of Output+Offset)	Current	≤0.1%+100mA
Line Regulation	Voltage	≤0.01%+20mV
±(% of Output+Offset)	Current	≤0.1%+100mA
Setup Resolution	Voltage	1mV
	Current	10mA
Read Back Resolution	Voltage	1mV
	Current	10mA
Setup Accuracy (within 12 months, 25°C±5° C)	Voltage	≤0.03%+20mV
	Current	≤0.1%+100mA
Read Back Accuracy (within 12 months, 25°C±5° C)	Voltage	≤0.03%+20mV
	Current	≤0.1%+100mA
Ripple	Voltage	≤80mVp-p
(20Hz -20MHz)	Current	≤100mArms

Parameter		IT-M3110
Setup Temperature Coefficient	Voltage	100 PPM/°C+20mV
±(PPM/°C+Offset)	Current	200 PPM/°C+30mA
Read Back Temperature Coefficient	Voltage	100 PPM/°C+20mV
±(PPM/°C+Offset)	Current	200 PPM/°C+30mA
Rise Time (no load)	Voltage	≤60mS
Rise Time (CR full load)	Voltage	≤150mS
Fall Time (no load)	Voltage	≤1S
Fall Time (CR full load)	Voltage	≤300mS
Transient Response Time	The output voltage is restored to within 0.5% of the rated output (10%-90%load)≤1mS	
Working Temperature	0-40°C	
Dimension (mm)	505*234*58	
Weight (net)	5Kg	
Parameter		
AC Input	Voltage	99V ~ 264V (rated power output)
	Frequency	47Hz~63Hz
Setup Stability-30min	Voltage	100 PPM/°C+10mV
(PPM+Offset)	Current	200 PPM/°C+50mA
Setup Stability-8h	Voltage	100 PPM/°C+10mV
(PPM+Offset)	Current	200 PPM/°C+50mA
Readback Stability-30min	Voltage	100 PPM/°C+10mV
(PPM+Offset)	Current	200 PPM/°C+70mA
Readback Stability-8h	Voltage	100 PPM/°C+10mV
(PPM+Offset)	Current	200 PPM/°C+70mA
Efficiency	76%	
Remote Sense Compensation Voltage	3V	
Command Response Time	10~600mS	
Power Factor	0.9	
Maximum Input Current	6A	
Maximum Input Apparent Power	600VA	

Parameter	IT-M3110
Storage Temperature	-10°C~70°C
Protective Function	OVP/OCP/OTP
Isolation (output to ground)	500V

5.1.2 IT-M3111

Parameter		IT-M3111
Rated value (0 °C-40 °C)	Voltage	0~30V
	Current	0~70A
	Power	400W
Load Regulation	Voltage	≤0.01%+30mV
±(% of Output+Offset)	Current	≤0.1%+100mA
Line Regulation	Voltage	≤0.01%+20mV
±(% of Output+Offset)	Current	≤0.1%+100mA
Setup Resolution	Voltage	1mV
	Current	10mA
Read Back Resolution	Voltage	1mV
	Current	10mA
Setup Accuracy (within 12 months, 25°C±5° C)	Voltage	≤0.03%+20mV
	Current	≤0.1%+70mA
Read Back Accuracy (within 12 months, 25°C±5° C)	Voltage	≤0.03%+20mV
	Current	≤0.1%+70mA
Ripple	Voltage	≤80mVp-p
(20Hz -20MHz)	Current	≤70mArms
Setup Temperature Coefficient	Voltage	100 PPM/°C+20mV
±(PPM/°C+Offset)	Current	200 PPM/°C+30mA
Read Back Temperature Coefficient	Voltage	100 PPM/°C+20mV
±(PPM/°C+Offset)	Current	200 PPM/°C+30mA

Parameter		IT-M3111
Rise Time (no load)	Voltage	≤60mS
Rise Time (CR full load)	Voltage	≤200mS
Fall Time (no load)	Voltage	≤3S
Fall Time (CR full load)	Voltage	≤300mS
Transient Response Time	The output voltage is restored to within 0.5% of the rated output (10%-90%load)≤1mS	
Working Temperature	0-40°C	
Dimension (mm)	505*234*58	
Weight (net)	5Kg	
Parameter		
AC Input	Voltage	99V ~ 264V (rated power output)
	Frequency	47Hz~63Hz
Setup Stability-30min	Voltage	100 PPM/°C+10mV
(PPM+Offset)	Current	200 PPM/°C+50mA
Setup Stability-8h	Voltage	100 PPM/°C+10mV
(PPM+Offset)	Current	200 PPM/°C+50mA
Readback Stability-30min	Voltage	100 PPM/°C+10mV
(PPM+Offset)	Current	200 PPM/°C+70mA
Readback Stability-8h	Voltage	100 PPM/°C+10mV
(PPM+Offset)	Current	200 PPM/°C+70mA
Efficiency	76%	
Remote Sense Compensation Voltage	3V	
Command Response Time	10~600mS	
Power Factor	0.9	
Maximum Input Current	6A	
Maximum Input Apparent Power	600VA	
Storage Temperature	-10°C~70°C	
Protective Function	OVP/OCP/OTP	
Isolation (output to ground)	500V	

5.1.3 IT-M3112

Parameter		IT-M3112
Rated value (0 °C-40 °C)	Voltage	0~80V
	Current	0~22A
	Power	400W
Load Regulation	Voltage	≤0.01%+40mV
±(% of Output+Offset)	Current	≤0.1%+20mA
Line Regulation	Voltage	≤0.01%+40mV
±(% of Output+Offset)	Current	≤0.1%+20mA
Setup Resolution	Voltage	1mV
	Current	1mA
Read Back Resolution	Voltage	1mV
	Current	1mA
Setup Accuracy (within 12 months, 25°C ±5°C)	Voltage	≤0.03%+40mV
	Current	≤0.1%+30mA
Read Back Accuracy (within 12 months, 25°C ±5°C)	Voltage	≤0.03%+40mV
	Current	≤0.1%+30mA
Ripple (20Hz -20MHz)	Voltage	≤100mVp-p
	Current	≤40mArms
Setup Temperature Coefficient	Voltage	100 PPM/°C+20mV
	Current	200 PPM/°C+30mA
Read Back Temperature Coefficient	Voltage	100 PPM/°C+20mV
	Current	200 PPM/°C+30mA
Rise Time (no load)	Voltage	≤60mS
Rise Time (CR full load)	Voltage	≤200mS
Fall Time (no load)	Voltage	≤4S
Fall Time (CR full load)	Voltage	≤300mS
Transient Response Time	The output voltage is restored to within 0.5% of the rated output (10%-90%load)≤1mS	

Parameter		IT-M3112
Working Temperature	0-40°C	
Dimension (mm)	505*234*58	
Weight (net)	5Kg	
Parameter		
AC Input	Voltage	99V ~ 264V (rated power output)
	Frequency	47Hz~63Hz
Setup Stability-30min	Voltage	100 PPM/°C+10mV
(PPM+Offset)	Current	200 PPM/°C+50mA
Setup Stability-8h	Voltage	100 PPM/°C+10mV
(PPM+Offset)	Current	200 PPM/°C+50mA
Readback Stability-30min	Voltage	100 PPM/°C+10mV
(PPM+Offset)	Current	200 PPM/°C+70mA
Readback Stability-8h	Voltage	100 PPM/°C+10mV
(PPM+Offset)	Current	200 PPM/°C+70mA
Efficiency	76%	
Remote Sense Compensation Voltage	3V	
Command Response Time	10~600mS	
Power Factor	0.9	
Maximum Input Current	6A	
Maximum Input Apparent Power	600VA	
Storage Temperature	-10°C~70°C	
Protective Function	OVP/OCP/OTP	
Isolation (output to ground)	500V	

5.1.4 IT-M3113

Parameter		IT-M3113
Rated value (0 °C-40 °C)	Voltage	0~150V
	Current	0~12A
	Power	400W
Load Regulation	Voltage	≤0.01%+100mV

Parameter		IT-M3113
±(% of Output+Offset)	Current	≤0.1%+20mA
Line Regulation	Voltage	≤0.01%+40mV
±(% of Output+Offset)	Current	≤0.1%+20mA
Setup Resolution	Voltage	10mV
	Current	1mA
Read Back Resolution	Voltage	10mV
	Current	1mA
Setup Accuracy (within 12 months, 25°C ±5°C)	Voltage	≤0.03%+75mV
	Current	≤0.1%+20mA
Read Back Accuracy (within 12 months, 25°C ±5°C)	Voltage	≤0.03%+75mV
	Current	≤0.1%+20mA
Ripple	Voltage	≤200mVp-p
(20Hz -20MHz)	Current	≤20mArms
Setup Temperature Coefficient	Voltage	100 PPM/°C+20mV
±(PPM/°C+Offset)	Current	200 PPM/°C+30mA
Read Back Temperature Coefficient	Voltage	100 PPM/°C+20mV
±(PPM/°C+Offset)	Current	200 PPM/°C+30mA
Rise Time (no load)	Voltage	≤60mS
Rise Time (CR full load)	Voltage	≤200mS
Fall Time (no load)	Voltage	≤4S
Fall Time (CR full load)	Voltage	≤300mS
Transient Response Time	The output voltage is restored to within 0.5% of the rated output (10%-90%load)≤1mS	
Working Temperature	0-40°C	
Dimension (mm)	505*234*58	
Weight (net)	5Kg	
Parameter		
AC Input	Voltage	99V ~ 264V (rated power output)

Parameter		IT-M3113
	Frequency	47Hz~63Hz
Setup Stability-30min	Voltage	100 PPM/°C+10mV
(PPM+Offset)	Current	200 PPM/°C+50mA
Setup Stability-8h	Voltage	100 PPM/°C+10mV
(PPM+Offset)	Current	200 PPM/°C+50mA
Readback Stability-30min	Voltage	100 PPM/°C+10mV
(PPM+Offset)	Current	200 PPM/°C+70mA
Readback Stability-8h	Voltage	100 PPM/°C+10mV
(PPM+Offset)	Current	200 PPM/°C+70mA
Efficiency		76%
Remote Sense Compensation Voltage		3V
Command Response Time		10~600mS
Power Factor		0.9
Maximum Input Current		6A
Maximum Input Apparent Power		600VA
Storage Temperature		-10°C~70°C
Protective Function		OVP/OCP/OTP
Isolation (output to ground)		500V

5.1.5 IT-M3114

Parameter		IT-M3114
Rated value (0 °C-40 °C)	Voltage	0~300V
	Current	0~6A
	Power	400W
Load Regulation	Voltage	≤0.01%+100mV
±(% of Output+Offset)	Current	≤0.1%+20mA
Line Regulation	Voltage	≤0.01%+150mV
±(% of Output+Offset)	Current	≤0.1%+20mA
Setup Resolution	Voltage	10mV
	Current	1mA

Parameter		IT-M3114
Read Back Resolution	Voltage	10mV
	Current	1mA
Setup Accuracy (within 12 months, 25°C ±5°C) ±(% of Output+Offset)	Voltage	≤0.03%+200mV
	Current	≤0.1%+20mA
Read Back Accuracy (within 12 months, 25°C ±5°C) ±(% of Output+Offset)	Voltage	≤0.03%+200mV
	Current	≤0.1%+20mA
Ripple (20Hz -20MHz)	Voltage	≤300mVp-p
	Current	≤50mA _{rms}
Setup Temperature Coefficient ±(PPM/°C+Offset)	Voltage	100 PPM/°C+100mV
	Current	200 PPM/°C+10mA
Read Back Temperature Coefficient ±(PPM/°C+Offset)	Voltage	100 PPM/°C+100mV
	Current	200 PPM/°C+10mA
Rise Time (no load)	Voltage	≤60mS
Rise Time (CR full load)	Voltage	≤200mS
Fall Time (no load)	Voltage	≤6S
Fall Time (CR full load)	Voltage	≤300mS
Transient Response Time	The output voltage is restored to within 0.5% of the rated output (10%-90%load)≤1mS	
Working Temperature	0-40°C	
Dimension (mm)	505*234*52.8	
Weight (net)	5Kg	
Parameter		
AC Input	Voltage	99V ~ 264V (rated power output)
	Frequency	47Hz~63Hz
Setup Stability-30min (PPM+Offset)	Voltage	100 PPM/°C+30mV
	Current	200 PPM/°C+60mA
Setup Stability-8h (PPM+Offset)	Voltage	100 PPM/°C+30mV
	Current	200 PPM/°C+60mA

Parameter		IT-M3114
Readback Stability-30min (PPM+Offset)	Voltage	100 PPM/°C+30mV
	Current	200 PPM/°C+60mA
Readback Stability-8h (PPM+Offset)	Voltage	100 PPM/°C+30mV
	Current	200 PPM/°C+60mA
Efficiency (Full voltage and full power)		76%
Remote Sense Compensation Voltage		3V
Command Response Time		10~600mS
Power Factor		0.9
Maximum Input Current		6A
Maximum Input Apparent Power		600VA
Storage Temperature		-10°C~70°C
Protective Function		OVP/OCP/OTP
Isolation (output to ground)		600V

5.1.6 IT-M3115

Parameter		IT-M3115
Rated value (0 °C-40 °C)	Voltage	0~600V
	Current	0~3A
	Power	400W
Load Regulation ±(% of Output+Offset)	Voltage	≤0.01%+150mV
	Current	≤0.1%+20mA
Line Regulation ±(% of Output+Offset)	Voltage	≤0.01%+150mV
	Current	≤0.1%+20mA
Setup Resolution	Voltage	10mV
	Current	1mA
Read Back Resolution	Voltage	10mV
	Current	1mA
Setup Accuracy (within 12 months, 25°C ±5°C)	Voltage	≤0.03%+200mV

Parameter		IT-M3115
±(% of Output+Offset)	Current	≤0.1%+10mA
Read Back Accuracy (within 12 months, 25°C ±5°C)	Voltage	≤0.03%+200mV
±(% of Output+Offset)	Current	≤0.1%+10mA
Ripple	Voltage	≤600mVp-p
(20Hz -20MHz)	Current	≤30mA _{rms}
Setup Temperature Coefficient	Voltage	100 PPM/°C+100mV
±(PPM/°C+Offset)	Current	200 PPM/°C+10mA
Read Back Temperature Coefficient	Voltage	100 PPM/°C+100mV
±(PPM/°C+Offset)	Current	200 PPM/°C+10mA
Rise Time (no load)	Voltage	≤100mS
Rise Time (CR full load)	Voltage	≤200mS
Fall Time (no load)	Voltage	≤6S
Fall Time (CR full load)	Voltage	≤300mS
Transient Response Time	The output voltage is restored to within 0.5% of the rated output (10%-90%load)≤1mS	
Working Temperature	0-40°C	
Dimension (mm)	505*234*58	
Weight (net)	5Kg	
Parameter		
AC Input	Voltage	99V ~ 264V (rated power output)
	Frequency	47Hz~63Hz
Setup Stability-30min	Voltage	100 PPM/°C+30mV
(PPM+Offset)	Current	200 PPM/°C+60mA
Setup Stability-8h	Voltage	100 PPM/°C+30mV
(PPM+Offset)	Current	200 PPM/°C+60mA
Readback Stability-30min	Voltage	100 PPM/°C+30mV
(PPM+Offset)	Current	200 PPM/°C+60mA
Readback Stability-8h	Voltage	100 PPM/°C+30mV
(PPM+Offset)	Current	200 PPM/°C+60mA

Parameter	IT-M3115
Efficiency (Full voltage and full power)	76%
Remote Sense Compensation Voltage	3V
Command Response Time	10~600mS
Power Factor	0.9
Maximum Input Current	6A
Maximum Input Apparent Power	600VA
Storage Temperature	-10°C~70°C
Protective Function	OVP/OCP/OTP
Isolation (output to ground)	600V

5.1.7 IT-M3120

Parameter		IT-M3120
Rated value (0 °C-40 °C)	Voltage	0~20V
	Current	0~100A
	Power	850W
Load Regulation	Voltage	≤0.01%+30mV
±(% of Output+Offset)	Current	≤0.1%+100mA
Line Regulation	Voltage	≤0.01%+20mV
±(% of Output+Offset)	Current	≤0.1%+100mA
Setup Resolution	Voltage	1mV
	Current	10mA
Read Back Resolution	Voltage	1mV
	Current	10mA
Setup Accuracy (within 12 months, 25°C ±5°C)	Voltage	≤0.03%+20mV
	Current	≤0.1%+100mA
Read Back Accuracy (within 12 months, 25°C ±5°C)	Voltage	≤0.03%+20mV

Parameter		IT-M3120
±(% of Output+Offset)	Current	≤0.1%+100mA
Ripple	Voltage	≤80mVp-p
(20Hz -20MHz)	Current	≤100mArms
Setup Temperature Coefficient	Voltage	100 PPM/°C+20mV
±(PPM/°C+Offset)	Current	200 PPM/°C+30mA
Read Back Temperature Coefficient	Voltage	100 PPM/°C+20mV
±(PPM/°C+Offset)	Current	200 PPM/°C+30mA
Rise Time (no load)	Voltage	≤60mS
Rise Time (CR full load)	Voltage	≤150mS
Fall Time (no load)	Voltage	≤1S
Fall Time (CR full load)	Voltage	≤300mS
Transient Response Time	The output voltage is restored to within 0.5% of the rated output (10%-90%load)≤1mS	
Working Temperature	0-40°C	
Dimension (mm)	505*234*58	
Weight (net)	5Kg	
Parameter		
AC Input	Voltage1	176V~ 264V (rated power output)
	Voltage2	99V~ 121V (power derating to 600W)
	Frequency	47Hz~63Hz
Setup Stability-30min	Voltage	100 PPM/°C+10mV
(PPM+Offset)	Current	200 PPM/°C+50mA
Setup Stability-8h	Voltage	100 PPM/°C+10mV
(PPM+Offset)	Current	200 PPM/°C+50mA
Readback Stability-30min	Voltage	100 PPM/°C+10mV
(PPM+Offset)	Current	200 PPM/°C+70mA
Readback Stability-8h	Voltage	100 PPM/°C+10mV
(PPM+Offset)	Current	200 PPM/°C+70mA
Efficiency	82%	
Remote Sense Compensation Voltage	3V	

Parameter	IT-M3120
Command Response Time	10~600mS
Power Factor	0.98
Maximum Input Current	11A
Maximum Input Apparent Power	1000VA
Storage Temperature	-10°C~70°C
Protective Function	OVP/OCP/OTP
Isolation (output to ground)	500V

5.1.8 IT-M3121

Parameter		IT-M3121
Rated value (0 °C-40 °C)	Voltage	0~30V
	Current	0~70A
	Power	850W
Load Regulation	Voltage	≤0.01%+30mV
±(% of Output+Offset)	Current	≤0.1%+100mA
Line Regulation	Voltage	≤0.01%+20mV
±(% of Output+Offset)	Current	≤0.1%+100mA
Setup Resolution	Voltage	1mV
	Current	10mA
Read Back Resolution	Voltage	1mV
	Current	10mA
Setup Accuracy (within 12 months, 25°C ±5°C)	Voltage	≤0.03%+20mV
	Current	≤0.1%+70mA
Read Back Accuracy (within 12 months, 25°C ±5°C)	Voltage	≤0.03%+20mV
	Current	≤0.1%+70mA
Ripple	Voltage	≤80mVp-p
(20Hz -20MHz)	Current	≤70mArms

Parameter		IT-M3121
Setup Temperature Coefficient	Voltage	100 PPM/°C+20mV
±(PPM/°C+Offset)	Current	200 PPM/°C+30mA
Read Back Temperature Coefficient	Voltage	100 PPM/°C+20mV
±(PPM/°C+Offset)	Current	200 PPM/°C+30mA
Rise Time (no load)	Voltage	≤60mS
Rise Time (CR full load)	Voltage	≤200mS
Fall Time (no load)	Voltage	≤3S
Fall Time (CR full load)	Voltage	≤300mS
Transient Response Time	The output voltage is restored to within 0.5% of the rated output (10%-90%load)≤1mS	
Working Temperature	0-40°C	
Dimension (mm)	505*234*58	
Weight (net)	5Kg	
Parameter		
AC Input	Voltage1	176V~ 264V (rated power output)
	Voltage2	99V~ 121V (power derating to 600W)
	Frequency	47Hz~63Hz
Setup Stability-30min	Voltage	100 PPM/°C+10mV
(PPM+Offset)	Current	200 PPM/°C+50mA
Setup Stability-8h	Voltage	100 PPM/°C+10mV
(PPM+Offset)	Current	200 PPM/°C+50mA
Readback Stability-30min	Voltage	100 PPM/°C+10mV
(PPM+Offset)	Current	200 PPM/°C+70mA
Readback Stability-8h	Voltage	100 PPM/°C+10mV
(PPM+Offset)	Current	200 PPM/°C+70mA
Efficiency	82%	
Remote Sense Compensation Voltage	3V	
Command Response Time	10~600mS	
Power Factor	0.98	
Maximum Input Current	11A	

Parameter	IT-M3121
Maximum Input Apparent Power	1100VA
Storage Temperature	-10°C~70°C
Protective Function	OVP/OCP/OTP
Isolation (output to ground)	500V

5.1.9 IT-M3122

Parameter	IT-M3122	
Rated value (0 °C-40 °C)	Voltage	0~80V
	Current	0~22A
	Power	850W
Load Regulation	Voltage	≤0.01%+40mV
±(% of Output+Offset)	Current	≤0.1%+20mA
Line Regulation	Voltage	≤0.01%+40mV
±(% of Output+Offset)	Current	≤0.1%+20mA
Setup Resolution	Voltage	1mV
	Current	1mA
Read Back Resolution	Voltage	1mV
	Current	1mA
Setup Accuracy (within 12 months, 25°C ±5°C)	Voltage	≤0.03%+40mV
	Current	≤0.1%+30mA
Read Back Accuracy (within 12 months, 25°C ±5°C)	Voltage	≤0.03%+40mV
	Current	≤0.1%+30mA
Ripple	Voltage	≤100mVp-p
(20Hz -20MHz)	Current	≤40mArms
Setup Temperature Coefficient	Voltage	100 PPM/°C+20mV
±(PPM/°C+Offset)	Current	200 PPM/°C+30mA

Parameter		IT-M3122
Read Back Temperature Coefficient	Voltage	100 PPM/°C+20mV
±(PPM/°C+Offset)	Current	200 PPM/°C+30mA
Rise Time (no load)	Voltage	≤60mS
Rise Time (CR full load)	Voltage	≤200mS
Fall Time (no load)	Voltage	≤4S
Fall Time (CR full load)	Voltage	≤300mS
Transient Response Time	The output voltage is restored to within 0.5% of the rated output (10%-90%load)≤1mS	
Working Temperature	0-40°C	
Dimension (mm)	505*234*58	
Weight (net)	5Kg	
Parameter		
AC Input	Voltage1	176V~ 264V (rated power output)
	Voltage2	99V~ 121V (power derating to 600W)
	Frequency	47Hz~63Hz
Setup Stability-30min	Voltage	100 PPM/°C+10mV
(PPM+Offset)	Current	200 PPM/°C+50mA
Setup Stability-8h	Voltage	100 PPM/°C+10mV
(PPM+Offset)	Current	200 PPM/°C+50mA
Readback Stability-30min	Voltage	100 PPM/°C+10mV
(PPM+Offset)	Current	200 PPM/°C+70mA
Readback Stability-8h	Voltage	100 PPM/°C+10mV
(PPM+Offset)	Current	200 PPM/°C+70mA
Efficiency	82%	
Remote Sense Compensation Voltage	3V	
Command Response Time	10~600mS	
Power Factor	0.98	
Maximum Input Current	11A	
Maximum Input Apparent Power	1100VA	
Storage Temperature	-10°C~70°C	

Parameter	IT-M3122
Protective Function	OVP/OC/OTP
Isolation (output to ground)	500V

5.1.10 IT-M3123

Parameter		IT-M3123
Rated value (0 °C-40 °C)	Voltage	0~150V
	Current	0~12A
	Power	850W
Load Regulation	Voltage	$\leq 0.01\% + 100\text{mV}$
\pm (% of Output+Offset)	Current	$\leq 0.1\% + 20\text{mA}$
Line Regulation	Voltage	$\leq 0.01\% + 40\text{mV}$
\pm (% of Output+Offset)	Current	$\leq 0.1\% + 20\text{mA}$
Setup Resolution	Voltage	10mV
	Current	1mA
Read Back Resolution	Voltage	10mV
	Current	1mA
Setup Accuracy (within 12 months, 25°C ±5°C)	Voltage	$\leq 0.03\% + 75\text{mV}$
	Current	$\leq 0.1\% + 20\text{mA}$
Read Back Accuracy (within 12 months, 25°C ±5°C)	Voltage	$\leq 0.03\% + 75\text{mV}$
	Current	$\leq 0.1\% + 20\text{mA}$
Ripple	Voltage	$\leq 200\text{mVp-p}$
(20Hz -20MHz)	Current	$\leq 20\text{mA}_{\text{rms}}$
Setup Temperature Coefficient	Voltage	100 PPM/°C+20mV
\pm (PPM/°C+Offset)	Current	200 PPM/°C+30mA
Read Back Temperature Coefficient	Voltage	100 PPM/°C+20mV
\pm (PPM/°C+Offset)	Current	200 PPM/°C+30mA
Rise Time (no load)	Voltage	$\leq 60\text{ms}$

Parameter		IT-M3123
Rise Time (CR full load)	Voltage	≤200mS
Fall Time (no load)	Voltage	≤4S
Fall Time (CR full load)	Voltage	≤300mS
Transient Response Time	The output voltage is restored to within 0.5% of the rated output (10%-90%load)≤1mS	
Working Temperature	0-40°C	
Dimension (mm)	505*234*58	
Weight (net)	5Kg	
Parameter		
AC Input	Voltage1	176V~ 264V (rated power output)
	Voltage2	99V~ 121V (power derating to 600W)
	Frequency	47Hz~63Hz
Setup Stability-30min	Voltage	100 PPM/°C+10mV
(PPM+Offset)	Current	200 PPM/°C+50mA
Setup Stability-8h	Voltage	100 PPM/°C+10mV
(PPM+Offset)	Current	200 PPM/°C+50mA
Readback Stability-30min	Voltage	100 PPM/°C+10mV
(PPM+Offset)	Current	200 PPM/°C+70mA
Readback Stability-8h	Voltage	100 PPM/°C+10mV
(PPM+Offset)	Current	200 PPM/°C+70mA
Efficiency	82%	
Remote Sense Compensation Voltage	3V	
Command Response Time	10~600mS	
Power Factor	0.98	
Maximum Input Current	11A	
Maximum Input Apparent Power	1100VA	
Storage Temperature	-10°C~70°C	
Protective Function	OVP/OCP/OTP	
Isolation (output to ground)	500V	

5.1.11 IT-M3124

Parameter		IT-M3124
Rated value (0 °C-40 °C)	Voltage	0~300V
	Current	0~6A
	Power	850W
Load Regulation	Voltage	≤0.01%+100mV
±(% of Output+Offset)	Current	≤0.1%+20mA
Line Regulation	Voltage	≤0.01%+150mV
±(% of Output+Offset)	Current	≤0.1%+20mA
Setup Resolution	Voltage	10mV
	Current	1mA
Read Back Resolution	Voltage	10mV
	Current	1mA
Setup Accuracy (within 12 months, 25°C ±5°C)	Voltage	≤0.03%+200mV
	Current	≤0.1%+20mA
Read Back Accuracy (within 12 months, 25°C ±5°C)	Voltage	≤0.03%+200mV
	Current	≤0.1%+20mA
Ripple	Voltage	≤300mVp-p
(20Hz -20MHz)	Current	≤50mArms
Setup Temperature Coefficient	Voltage	100 PPM/°C+100mV
±(PPM/°C+Offset)	Current	200 PPM/°C+10mA
Read Back Temperature Coefficient	Voltage	100 PPM/°C+100mV
±(PPM/°C+Offset)	Current	200 PPM/°C+10mA
Rise Time (no load)	Voltage	≤60mS
Rise Time (CR full load)	Voltage	≤200mS
Fall Time (no load)	Voltage	≤6S
Fall Time (CR full load)	Voltage	≤300mS
Transient Response Time	The output voltage is restored to within 0.5% of the rated output (10%-90%load)≤1mS	

Parameter		IT-M3124
Working Temperature	0-40°C	
Dimension (mm)	505*234*58	
Weight (net)	5Kg	
Parameter		
AC Input	Voltage1	176V~ 264V (rated power output)
	Voltage2	99V~ 121V (power derating to 600W)
	Frequency	47Hz~63Hz
Setup Stability-30min (PPM+Offset)	Voltage	100 PPM/°C+30mV
	Current	200 PPM/°C+60mA
Setup Stability-8h (PPM+Offset)	Voltage	100 PPM/°C+30mV
	Current	200 PPM/°C+60mA
Readback Stability-30min (PPM+Offset)	Voltage	100 PPM/°C+30mV
	Current	200 PPM/°C+60mA
Readback Stability-8h (PPM+Offset)	Voltage	100 PPM/°C+30mV
	Current	200 PPM/°C+60mA
Efficiency (Full voltage and full power)	82%	
Remote Sense Compensation Voltage	3V	
Command Response Time	10~600mS	
Power Factor	0.98	
Maximum Input Current	11A	
Maximum Input Apparent Power	1100VA	
Storage Temperature	-10°C~70°C	
Protective Function	OVP/OCP/OTP	
Isolation (output to ground)	600V	

5.1.12 IT-M3125

Parameter		IT-M3125
Rated value (0 °C-40 °C)	Voltage	0~600V
	Current	0~3A

Parameter		IT-M3125
	Power	850W
Load Regulation	Voltage	$\leq 0.01\% + 150\text{mV}$
\pm (% of Output+Offset)	Current	$\leq 0.1\% + 20\text{mA}$
Line Regulation	Voltage	$\leq 0.01\% + 150\text{mV}$
\pm (% of Output+Offset)	Current	$\leq 0.1\% + 20\text{mA}$
Setup Resolution	Voltage	10mV
	Current	1mA
Read Back Resolution	Voltage	10mV
	Current	1mA
Setup Accuracy (within 12 months, 25°C ±5°C)	Voltage	$\leq 0.03\% + 200\text{mV}$
	Current	$\leq 0.1\% + 10\text{mA}$
Read Back Accuracy (within 12 months, 25°C ±5°C)	Voltage	$\leq 0.03\% + 200\text{mV}$
	Current	$\leq 0.1\% + 10\text{mA}$
Ripple (20Hz -20MHz)	Voltage	$\leq 600\text{mVp-p}$
	Current	$\leq 30\text{mA}_{\text{rms}}$
Setup Temperature Coefficient	Voltage	100 PPM/°C+100mV
	Current	200 PPM/°C+10mA
Read Back Temperature Coefficient	Voltage	100 PPM/°C+100mV
	Current	200 PPM/°C+10mA
Rise Time (no load)	Voltage	$\leq 60\text{mS}$
Rise Time (CR full load)	Voltage	$\leq 200\text{mS}$
Fall Time (no load)	Voltage	$\leq 6\text{S}$
Fall Time (CR full load)	Voltage	$\leq 300\text{mS}$
Transient Response Time	The output voltage is restored to within 0.5% of the rated output (10%-90%load) $\leq 1\text{mS}$	
Working Temperature	0-40°C	
Dimension (mm)	505*234*58	
Weight (net)	5Kg	

Parameter		IT-M3125
Parameter		
AC Input	Voltage1	176V~ 264V (rated power output)
	Voltage2	99V~ 121V (power derating to 600W)
	Frequency	47Hz~63Hz
Setup Stability-30min	Voltage	100 PPM/°C+30mV
(PPM+Offset)	Current	200 PPM/°C+60mA
Setup Stability-8h	Voltage	100 PPM/°C+30mV
(PPM+Offset)	Current	200 PPM/°C+60mA
Readback Stability-30min	Voltage	100 PPM/°C+30mV
(PPM+Offset)	Current	200 PPM/°C+60mA
Readback Stability-8h	Voltage	100 PPM/°C+30mV
(PPM+Offset)	Current	200 PPM/°C+60mA
Efficiency (Full voltage and full power)	82%	
Remote Sense Compensation Voltage	3V	
Command Response Time	10~600mS	
Power Factor	0.98	
Maximum Input Current	11A	
Maximum Input Apparent Power	1100VA	
Storage Temperature	-10°C~70°C	
Protective Function	OVP/OCP/OTP	
Isolation (output to ground)	600V	

5.1.13 IT-M3120S

Parameter		IT-M3120S
Rated value (0 °C-40 °C)	Voltage	0~60V
	Current	0~35A
	Power	800W
Load Regulation	Voltage	≤0.01%+30mV
±(%of Output+Offset)	Current	≤0.1%+20mA

Parameter		IT-M3120S
Line Regulation	Voltage	$\leq 0.01\% + 30\text{mV}$
$\pm(\% \text{ of Output} + \text{Offset})$	Current	$\leq 0.1\% + 20\text{mA}$
Setup Resolution	Voltage	1mV
	Current	1mA
Read Back Resolution	Voltage	1mV
	Current	1mA
Setup Accuracy	Voltage	$\leq 0.03\% + 30\text{mV}$
(within 12 months, 25°C ±5°C)		
$\pm(\% \text{ of Output} + \text{Offset})$	Current	$\leq 0.1\% + 30\text{mA}$
Read Back Accuracy	Voltage	$\leq 0.03\% + 30\text{mV}$
(within 12 months, 25°C ±5°C)		
$\pm(\% \text{ of Output} + \text{Offset})$	Current	$\leq 0.1\% + 30\text{mA}$
Ripple	Voltage	$\leq 80\text{mVp-p}$
(20Hz -20MHz)	Current	$\leq 35\text{mA}_{\text{rms}}$
Setup Temperature Coefficient	Voltage	100 PPM/°C+20mV
\pm (PPM/°C+Offset)	Current	200 PPM/°C+30mA
Read Back Temperature Coefficient	Voltage	100 PPM/°C+20mV
\pm (PPM/°C+Offset)	Current	200 PPM/°C+30mA
Rise Time(no load)	Voltage	$\leq 40\text{mS}$
Rise time (CR full load)	Voltage	$\leq 80\text{mS}$
Fall Time(no load)	Voltage	$\leq 4\text{S}$
Fall time (CR full load)	Voltage	$\leq 300\text{mS}$
Transient Response Time	The output voltage returns to within 0.5% of the rated value (10%-90%load) $\leq 1\text{mS}$	
Working Temperature	0-40°C	
Dimension (mm)	505*234*58	
Weight(net)	5Kg	
Parameter		
AC Input	Voltage 1	176V~ 264V (rated power output)
	Voltage 2	99V~ 121V (power derating to 600W)

Parameter		IT-M3120S
	Frequency	47Hz~63Hz
Setup Stability-30min	Voltage	100 PPM/°C+10mV
(PPM+Offset)	Current	200 PPM/°C+50mA
Setup stability-8h	Voltage	100 PPM/°C+10mV
(PPM+Offset)	Current	200 PPM/°C+50mA
Readback Stability-30min	Voltage	100 PPM/°C+10mV
(PPM+Offset)	Current	200 PPM/°C+70mA
Readback stability-8h	Voltage	100 PPM/°C+10mV
(PPM+Offset)	Current	200 PPM/°C+70mA
Efficiency		82%
Remote Sense Compensation Voltage		3V
Command Response Time		10~600mS
Power Factor		0.98
Maximum Input Current		10A
Maximum Input Apparent Power		1000VA
Storage Temperature		-10°C~70°C
Protective Function		OVP/OCP/OTP
Isolation (output to ground)		500V

5.1.14 IT-M3112S

Parameter		IT-M3112S
Rated value (0 °C-40 °C)	Voltage	0~60V
	Current	0~20A
	Power	200W
Load Regulation	Voltage	≤0.01%+30mV
±(% of Output+Offset)	Current	≤0.1%+20mA
Line Regulation	Voltage	≤0.01%+30mV
±(% of Output+Offset)	Current	≤0.1%+20mA
Setup Resolution	Voltage	1mV
	Current	1mA

Parameter		IT-M3112S
Read Back Resolution	Voltage	1mV
	Current	1mA
Setup Accuracy	Voltage	$\leq 0.03\% + 30\text{mV}$
(within 12 months, 25°C ±5°C)		
±(% of Output+Offset)	Current	$\leq 0.1\% + 30\text{mA}$
Read Back Accuracy	Voltage	$\leq 0.03\% + 30\text{mV}$
(within 12 months, 25°C ±5°C)		
±(% of Output+Offset)	Current	$\leq 0.1\% + 30\text{mA}$
Ripple	Voltage	$\leq 80\text{mVp-p}$
(20Hz -20MHz)	Current	$\leq 35\text{mA}_{\text{rms}}$
Setup Temperature Coefficient	Voltage	100 PPM/°C+20mV
± (PPM/°C+Offset)	Current	200 PPM/°C+30mA
Read Back Temperature Coefficient	Voltage	100 PPM/°C+20mV
± (PPM/°C+Offset)	Current	200 PPM/°C+30mA
Rise Time(no load)	Voltage	$\leq 40\text{mS}$
Rise time (CR full load)	Voltage	$\leq 60\text{mS}$
Fall Time(no load)	Voltage	$\leq 4\text{S}$
Fall time (CR full load)	Voltage	$\leq 300\text{mS}$
Transient Response Time	The output voltage returns to within 0.5% of the rated value (10%-90%load) $\leq 1\text{mS}$	
Working Temperature	0-40°C	
Dimension (mm)	505*234*58	
Weight(net)	5Kg	
Parameter		
AC Input	Voltage	99V ~ 264V (rated power output)
	Frequency	47Hz~63Hz
Setup Stability-30min	Voltage	100 PPM/°C+10mV
(PPM+Offset)	Current	200 PPM/°C+50mA
Setup stability-8h	Voltage	100 PPM/°C+10mV
(PPM+Offset)	Current	200 PPM/°C+50mA

Parameter		IT-M3112S
Readback Stability-30min	Voltage	100 PPM/°C+10mV
(PPM+Offset)	Current	200 PPM/°C+70mA
Readback stability-8h	Voltage	100 PPM/°C+10mV
(PPM+Offset)	Current	200 PPM/°C+70mA
Efficiency		74%
Remote Sense Compensation Voltage		3V
Command Response Time		10~600mS
Power Factor		0.98
Maximum Input Current		5A
Maximum Input Apparent Power		500VA
Storage Temperature		-10°C~70°C
Protective Function		OVP/OCP/OTP
Isolation (output to ground)		500V

5.1.15 IT-M3130

Parameter		Model: IT-M3130
Rated value	Voltage	0 ~ 20V
	Current	0 ~ 120A
	Power	0 ~ 1500W
Line Regulation ±(% of Output+Offset)	Voltage	0.001%+2mV
	Current	≤30mA
Load Regulation ±(% of Output+Offset)	Voltage	0.005%+3mV
	Current	≤30mA
Setup Resolution	Voltage	1mV
	Current	1mA
	Power	0.1W
Read Back Resolution	Voltage	1mV
	Current	1mA
Setup Accuracy	Voltage	≤0.03% + 0.02%F.S.
	Current	≤0.05% + 0.05%F.S.

Parameter		Model: IT-M3130
	Power	$\leq 0.1\% + 0.15\% \text{F.S.}$
Read Back Accuracy	Voltage	$\leq 0.03\% + 0.02\% \text{F.S.}$
	Current	$\leq 0.05\% + 0.05\% \text{F.S.}$
	Power	$\leq 0.1\% + 0.15\% \text{F.S.}$
Ripple (20hz-20Mhz)	Vpp	$\leq 50\text{mV}$
	Irms	$\leq 120\text{mA}$
Setup Temperature Coefficient (% of Output + Offset) / °C	Voltage	$\leq 20\text{PPM}/^\circ\text{C}$
	Current	$\leq 50\text{PPM}/^\circ\text{C}$
Read Back Temperature Coefficient (% of Output + Offset) / °C	Voltage	$\leq 20\text{PPM}/^\circ\text{C}$
	Current	$\leq 50\text{PPM}/^\circ\text{C}$
Rise Time(no load)	Voltage	$\leq 60\text{ms}$
Rise Time(full load)	Voltage	$\leq 150\text{ms}$
Fall Time(no load)	Voltage	$\leq 2\text{s}$
Fall Time(full load)	Voltage	$\leq 200\text{ms}$
Transient Response Time	Voltage	$\leq 1\text{ms}$
AC Input	Voltage	176VAC-264VAC (rated power output)
		99VAC-121VAC (power derating to 750W)
	Frequency	47-63Hz
Setup stability-30min (% of Output + Offset)	Voltage	0.01%+2mV
	Current	0.01%+35mA
Setup stability-8h (% of Output + Offset)	Voltage	0.01%+2mV
	Current	0.01%+35mA
Readback stability-30min (% of Output + Offset)	Voltage	0.01%+2mV
	Current	0.01%+35mA
Readback stability-8h (% of Output + Offset)	Voltage	0.01%+2mV
	Current	0.01%+35mA
Efficiency		89%
Remote Sense Compensation Voltage		$\leq 3\text{V}$
Command Response Time		5ms
Power Factor		0.99
Maximum Input Current		12A
Maximum Input Apparent Power		1800VA

Parameter	Model: IT-M3130
Storage Temperature	-10°C ~ 70°C
Protective Function	OVP / OCP / OTP / OPP / UVP / UCP / Sense reverse protection
Standard Interface	Optional: RS485 LAN USB CAN external analog GPIB
Isolation (output to ground)	500VDC
Isolation (input to ground)	2200VDC
Working Temperature	0 ~ 40°C
Ingress Protection	IP20
Production Compliance	IEC 61010
Cooling	Air cooling
Dimensions without legs and terminals (mm)	207W*450D*34H
Overall dimension (mm)	234W*505D*58H
Weight(net)	(6±0.5)kg

5.1.16 IT-M3131

Parameter		Model: IT-M3131
Rated value	Voltage	0 ~ 30V
	Current	0 ~ 100A
	Power	0 ~ 1500W
Line Regulation ±(% of Output+Offset)	Voltage	0.001%+2mV
	Current	≤20mA
Load Regulation ±(% of Output+Offset)	Voltage	0.005%+3mV
	Current	≤25mA
Setup Resolution	Voltage	1mV
	Current	1mA
	Power	0.1W
Read Back Resolution	Voltage	1mV
	Current	1mA
Setup Accuracy	Voltage	≤0.03% + 0.02%F.S.
	Current	≤0.05% + 0.05%F.S.
	Power	≤0.1% +0.15%F.S.

Parameter		Model: IT-M3131
Read Back Accuracy	Voltage	$\leq 0.03\% + 0.02\% \text{F.S.}$
	Current	$\leq 0.1\% + 0.1\% \text{F.S.}$
	Power	$\leq 0.1\% + 0.15\% \text{F.S.}$
Ripple (20hz-20Mhz)	V _{pp}	$\leq 50 \text{ mV}$
	I _{rms}	$\leq 100 \text{ mA}$
Setup Temperature Coefficient (% of Output + Offset) / °C	Voltage	$\leq 20 \text{ PPM}/^\circ\text{C}$
	Current	$\leq 50 \text{ PPM}/^\circ\text{C}$
Read Back Temperature Coefficient (% of Output + Offset) / °C	Voltage	$\leq 20 \text{ PPM}/^\circ\text{C}$
	Current	$\leq 50 \text{ PPM}/^\circ\text{C}$
Rise Time(no load)	Voltage	$\leq 60 \text{ ms}$
Rise Time(full load)	Voltage	$\leq 150 \text{ ms}$
Fall Time(no load)	Voltage	$\leq 2 \text{ s}$
Fall Time(full load)	Voltage	$\leq 200 \text{ ms}$
Transient Response Time	Voltage	$\leq 1 \text{ ms}$
AC Input	Voltage	176VAC-264VAC (rated power output)
		99VAC-121VAC (power derating to 750W)
	Frequency	47-63Hz
Setup stability-30min (% of Output + Offset)	Voltage	0.01%+2mV
	Current	0.01%+25mA
Setup stability-8h (% of Output + Offset)	Voltage	0.01%+2mV
	Current	0.01%+25mA
Readback stability-30min (% of Output + Offset)	Voltage	0.01%+2mV
	Current	0.01%+25mA
Readback stability-8h (% of Output + Offset)	Voltage	0.01%+2mV
	Current	0.01%+25mA
Efficiency		89%
Remote Sense Compensation Voltage		$\leq 3 \text{ V}$
Command Response Time		5ms
Power Factor		0.99
Maximum Input Current		12A
Maximum Input Apparent Power		1800VA
Storage Temperature		-10°C ~ 70°C

Parameter	Model: IT-M3131
Protective Function	OVP / OCP / OTP / OPP / UVP / UCP / Sense reverse protection
Standard Interface	Optional: RS485 LAN USB CAN external analog GPIB
Isolation (output to ground)	500VDC
Isolation (input to ground)	2200VDC
Working Temperature	0 ~ 40°C
Ingress Protection	IP20
Production Compliance	IEC 61010
Cooling	Air cooling
Dimensions without legs and terminals (mm)	207W*450D*34H
Overall dimension (mm)	234W*505D*58H
Weight(net)	(6±0.5)kg

5.1.17 IT-M3132

Parameter	Model: IT-M3132	
Rated value	Voltage	0 ~ 80V
	Current	0 ~ 40A
	Power	0 ~ 1500W
Line Regulation ±(% of Output+Offset)	Voltage	0.001%+5mV
	Current	≤10mA
Load Regulation ±(% of Output+Offset)	Voltage	0.004%+5mV
	Current	≤10mA
Setup Resolution	Voltage	1mV
	Current	1mA
	Power	0.1W
Read Back Resolution	Voltage	1mV
	Current	1mA
Setup Accuracy	Voltage	≤0.03% + 0.02%F.S.
	Current	≤0.05% + 0.05%F.S.
	Power	≤0.1%+0.15%F.S.
Read Back Accuracy	Voltage	≤0.03% + 0.02%F.S.

Parameter		Model: IT-M3132
	Current	$\leq 0.05\% + 0.05\% \text{F.S.}$
	Power	$\leq 0.1\% + 0.15\% \text{F.S.}$
Ripple (20hz-20Mhz)	Vpp	$\leq 140\text{mV}$
	Irms	$\leq 40\text{mA}$
Setup Temperature Coefficient (% of Output+Offset)/°C	Voltage	$\leq 20\text{PPM}/^\circ\text{C}$
	Current	$\leq 50\text{PPM}/^\circ\text{C}$
Read Back Temperature Coefficient (% of Output +Offset)/°C	Voltage	$\leq 20\text{PPM}/^\circ\text{C}$
	Current	$\leq 50\text{PPM}/^\circ\text{C}$
Rise Time(no load)	Voltage	$\leq 60\text{ms}$
Rise Time(full load)	Voltage	$\leq 150\text{ms}$
Fall Time(no load)	Voltage	$\leq 2\text{s}$
Fall Time(full load)	Voltage	$\leq 200\text{ms}$
Transient Response Time	Voltage	$\leq 1\text{ms}$
AC Input	Voltage	176VAC-264VAC (rated power output)
		99VAC-121VAC (power derating to 750W)
	Frequency	47-63Hz
Setup stability-30min (% of Output +Offset)	Voltage	0.01%+8mV
	Current	0.01%+10mA
Setup stability-8h (% of Output +Offset)	Voltage	0.01%+10mV
	Current	0.01%+10mA
Readback stability-30min (% of Output +Offset)	Voltage	0.01%+8mV
	Current	0.01%+10mA
Readback stability-8h (% of Output +Offset)	Voltage	0.01%+10mV
	Current	0.01%+10mA
Efficiency		89%
Remote Sense Compensation Voltage		$\leq 3\text{V}$
Command Response Time		5ms
Power Factor		0.99
Maximum Input Current		12A
Maximum Input Apparent Power		1800VA
Storage Temperature		$-10^\circ\text{C} \sim 70^\circ\text{C}$
Protective Function		OVP / OCP / OTP / OPP / UVP / UCP / Sense reverse protection

Parameter	Model: IT-M3132
Standard Interface	Optional: RS485 LAN USB CAN external analog GPIB
Isolation (output to ground)	500VDC
Isolation (input to ground)	2200VDC
Working Temperature	0 ~ 40°C
Ingress Protection	IP20
Production Compliance	IEC 61010
Cooling	Air cooling
Dimensions without legs and terminals (mm)	207W*450D*34H
Overall dimension (mm)	234W*505D*58H
Weight(net)	(6±0.5)kg

5.1.18 IT-M3133

Parameter	Model: IT-M3133	
Rated value	Voltage	0 ~ 150V
	Current	0 ~ 20A
	Power	0 ~ 1500W
Line Regulation ±(% of Output+Offset)	Voltage	0.001%+10mV
	Current	≤5mA
Load Regulation ±(% of Output+Offset)	Voltage	0.004%+12mV
	Current	≤5mA
Setup Resolution	Voltage	10mV
	Current	1mA
	Power	0.1W
Read Back Resolution	Voltage	10mV
	Current	1mA
Setup Accuracy	Voltage	≤0.03% + 0.02%F.S.
	Current	≤0.05% + 0.05%F.S.
	Power	≤0.1%+0.15%F.S.
Read Back Accuracy	Voltage	≤0.03% + 0.02%F.S.
	Current	≤0.05% + 0.05%F.S.
	Power	≤0.1%+0.15%F.S.

Parameter		Model: IT-M3133
Ripple (20hz-20Mhz)	Vpp	≤150mV
	Irms	≤20mA
Setup Temperature Coefficient (% of Output+Offset)/°C	Voltage	≤20PPM/°C
	Current	≤50PPM/°C
Read Back Temperature Coefficient (% of Output +Offset)/°C	Voltage	≤20PPM/°C
	Current	≤50PPM/°C
Rise Time(no load)	Voltage	≤60ms
Rise Time(full load)	Voltage	≤150ms
Fall Time(no load)	Voltage	≤2s
Fall Time(full load)	Voltage	≤200ms
Transient Response Time	Voltage	≤1ms
AC Input	Voltage	176VAC-264VAC (rated power output)
		99VAC-121VAC (power derating to 750W)
	Frequency	47-63Hz
Setup stability-30min (% of Output +Offset)	Voltage	0.01%+10mV
	Current	0.01%+4mA
Setup stability-8h (% of Output +Offset)	Voltage	0.01%+12mV
	Current	0.01%+4mA
Readback stability-30min (% of Output +Offset)	Voltage	0.01%+10mV
	Current	0.01%+4mA
Readback stability-8h (% of Output +Offset)	Voltage	0.01%+12mV
	Current	0.01%+4mA
Efficiency		89%
Remote Sense Compensation Voltage		≤3V
Command Response Time		5ms
Power Factor		0.99
Maximum Input Current		12A
Maximum Input Apparent Power		1800VA
Storage Temperature		-10°C ~ 70°C
Protective Function		OVP / OCP / OTP / OPP / UVP / UCP / Sense reverse protection

Parameter	Model: IT-M3133
Standard Interface	Optional: RS485 LAN USB CAN external analog GPIB
Isolation (output to ground)	500VDC
Isolation (input to ground)	2200VDC
Working Temperature	0 ~ 40°C
Ingress Protection	IP20
Production Compliance	IEC 61010
Cooling	Air cooling
Dimensions without legs and terminals (mm)	207W*450D*34H
Overall dimension (mm)	234W*505D*58H
Weight(net)	(6±0.5)kg

5.1.19 IT-M3134

Parameter	Model: IT-M3134	
Rated value	Voltage	0 ~ 300V
	Current	0 ~ 10A
	Power	0 ~ 1500W
Line Regulation ±(% of Output+Offset)	Voltage	0.004%+20mV
	Current	≤3mA
Load Regulation ±(% of Output+Offset)	Voltage	0.004%+20mV
	Current	≤3mA
Setup Resolution	Voltage	10mV
	Current	1mA
	Power	0.1W
Read Back Resolution	Voltage	10mV
	Current	1mA
Setup Accuracy	Voltage	≤0.03% + 0.02%F.S.
	Current	≤0.05% + 0.05%F.S.
	Power	≤0.1%+0.15%F.S.
Read Back Accuracy	Voltage	≤0.03% + 0.02%F.S.
	Current	≤0.05% + 0.05%F.S.
	Power	≤0.1%+0.15%F.S.

Parameter		Model: IT-M3134
Ripple (20hz-20Mhz)	Vpp	≤300mV
	Irms	≤10mA
Setup Temperature Coefficient (%of Output +Offset)/°C	Voltage	≤20PPM/°C
	Current	≤50PPM/°C
Read Back Temperature Coefficient (%of Output+Offset)/°C	Voltage	≤20PPM/°C
	Current	≤50PPM/°C
Rise Time(no load)	Voltage	≤60ms
Rise Time(full load)	Voltage	≤150ms
Fall Time(no load)	Voltage	≤2s
Fall Time(full load)	Voltage	≤200ms
Transient Response Time	Voltage	≤1ms
AC Input	Voltage	176VAC-264VAC (rated power output)
		99VAC-121VAC (power derating to 750W)
	Frequency	47-63Hz
Setup stability-30min (%of Output +Offset)	Voltage	0.005%+25mV
	Current	0.01%+2.5mA
Setup stability-8h (%of Output +Offset)	Voltage	0.005%+25mV
	Current	0.01%+2.5mA
Readback stability-30min (%of Output +Offset)	Voltage	0.005%+25mV
	Current	0.01%+2.5mA
Readback stability-8h (%of Output +Offset)	Voltage	0.005%+25mV
	Current	0.01%+2.5mA
Efficiency		89%
Remote Sense Compensation Voltage		≤3V
Command Response Time		5ms
Power Factor		0.99
Maximum Input Current		12A
Maximum Input Apparent Power		1800VA
Storage Temperature		-10°C ~ 70°C
Protective Function		OVP / OCP / OTP / OPP / UVP / UCP / Sense reverse protection

Parameter	Model: IT-M3134
Standard Interface	Optional: RS485 LAN USB CAN external analog GPIB
Isolation (output to ground)	500VDC
Isolation (input to ground)	2200VDC
Working Temperature	0 ~ 40°C
Ingress Protection	IP20
Production Compliance	IEC 61010
Cooling	Air cooling
Dimensions without legs and terminals (mm)	207W*450D*34H
Overall dimension (mm)	234W*505D*58H
Weight(net)	(6±0.5)kg

5.1.20 IT-M3135

Parameter		Model: IT-M3135
Rated value	Voltage	0 ~ 600V
	Current	0 ~ 5A
	Power	0 ~ 1500W
Line Regulation ±(% of Output+Offset)	Voltage	0.004%+30mV
	Current	≤1.5mA
Load Regulation ±(% of Output+Offset)	Voltage	0.004%+30mV
	Current	≤1.5mA
Setup Resolution	Voltage	10mV
	Current	1mA
	Power	0.1W
Read Back Resolution	Voltage	10mV
	Current	1mA
Setup Accuracy	Voltage	≤0.03% + 0.02%F.S.
	Current	≤0.05% + 0.05%F.S.
	Power	≤0.1%+0.15%F.S.
Read Back Accuracy	Voltage	≤0.03% + 0.02%F.S.
	Current	≤0.05% + 0.05%F.S.
	Power	≤0.1%+0.15%F.S.

Parameter		Model: IT-M3135
Ripple (20hz-20Mhz)	Vpp	≤600mV
	Irms	≤10mA
Setup Temperature Coefficient (%of Output+Offset)/°C	Voltage	≤20PPM/°C
	Current	≤50PPM/°C
Read Back Temperature Coefficient (%of Output +Offset)/°C	Voltage	≤20PPM/°C
	Current	≤50PPM/°C
Rise Time(no load)	Voltage	≤60ms
Rise Time(full load)	Voltage	≤150ms
Fall Time(no load)	Voltage	≤2s
Fall Time(full load)	Voltage	≤200ms
Transient Response Time	Voltage	≤1ms
AC Input	Voltage	176VAC-264VAC (rated power output)
		99VAC-121VAC (power derating to 750W)
	Frequency	47-63Hz
Setup stability-30min (%of Output +Offset)	Voltage	0.005%+45mV
	Current	0.01%+1.6mA
Setup stability-8h (%of Output +Offset)	Voltage	0.005%+45mV
	Current	0.01%+1.6mA
Readback stability-30min (%of Output +Offset)	Voltage	0.005%+45mV
	Current	0.01%+1.6mA
Readback stability-8h (%of Output +Offset)	Voltage	0.005%+45mV
	Current	0.01%+1.6mA
Efficiency		88%
Remote Sense Compensation Voltage		≤3V
Command Response Time		5ms
Power Factor		0.99
Maximum Input Current		12A
Maximum Input Apparent Power		1800VA
Storage Temperature		-10°C ~ 70°C
Protective Function		OVP / OCP / OTP / OPP / UVP / UCP / Sense reverse protection
Standard Interface		Optional: RS485 LAN USB CAN external analog GPIB

Parameter	Model: IT-M3135
Isolation (output to ground)	1000VDC
Isolation (input to ground)	2200VDC
Working Temperature	0 ~ 40°C
Ingress Protection	IP20
Production Compliance	IEC 61010
Cooling	Air cooling
Dimensions without legs and terminals (mm)	207W*450D*34H
Overall dimension (mm)	234W*505D*58H
Weight(net)	(6±0.5)kg

5.1.21 IT-M3116

Parameter		Model: IT-M3116
Rated value	Voltage	0 ~ 1000V
	Current	0 ~ 3A
	Power	0 ~ 400W
Line Regulation	Voltage	0.004%+30mV
±(% of Output+Offset)	Current	≤0.8mA
Load Regulation	Voltage	0.004%+30mV
±(% of Output+Offset)	Current	≤0.8mA
Setup Resolution	Voltage	100mV
	Current	1mA
	Power	0.1W
Read Back Resolution	Voltage	100mV
	Current	1mA
Setup Accuracy	Voltage	≤0.02% + 0.02%F.S.
	Current	≤0.05% + 0.05%F.S.
	Power	≤0.2%+0.3%F.S.
Read Back Accuracy	Voltage	≤0.02% + 0.02%F.S.
	Current	≤0.05% + 0.05%F.S.
	Power	≤0.2%+0.3%F.S.
Ripple (20hz-20Mhz)	Vpp	≤1000mV

Parameter		Model: IT-M3116
	I _{rms}	≤5mA
Setup Temperature Coefficient	Voltage	≤20PPM/°C
(%of Output+Offset)/°C	Current	≤50PPM/°C
Read Back Temperature Coefficient	Voltage	≤20PPM/°C
(%of Output+Offset)/°C	Current	≤50PPM/°C
Rise Time(no load)	Voltage	≤60ms
Rise Time(full load)	Voltage	≤300ms
Fall Time(no load)	Voltage	≤2s
Fall Time(full load)	Voltage	≤200ms
Transient Response Time	Voltage	≤1ms
		(Returns the output voltage to within 0.5% of the rated output voltage value)
AC Input	Voltage	99VAC-264VAC (rated power output)
	Frequency	47-63Hz
Setup Stability-30min	Voltage	0.005%+60mV
±(%of Output+Offset)	Current	0.01%+0.9mA
Setup stability-8h	Voltage	0.005%+60mV
±(%of Output+Offset)	Current	0.01%+0.9mA
Readback Stability-30min	Voltage	0.005%+60mV
±(%of Output+Offset)	Current	0.01%+0.9mA
Readback stability-8h	Voltage	0.005%+60mV
±(%of Output+Offset)	Current	0.01%+0.9mA
Efficiency		81%
Remote Sense Compensation Voltage		≤3V
Command Response Time		5ms
Power Factor		0.97
Maximum Input Current		6A
Maximum Input Apparent Power		500VA
Storage Temperature		-10°C ~ 70°C
Protective Function		OVP/OCP/OTP/OPP/UVP/UCP
		Sense reverse protection

Parameter	Model: IT-M3116
Standard Interface	Optional: RS485 LAN USB CAN
	External analog GPIB
Isolation (output to ground)	1200VDC
Isolation (input to ground)	2200VDC
Working Temperature	0 ~ 40°C
Ingress Protection	IP20
Production Compliance	IEC 61010
Cooling	Air cooling
Dimensions without legs and terminals (mm)	207W*450D*34H
Overall dimension (mm)	234W*505D*58H
Weight(net)	(6±0.5)kg

5.1.22 IT-M3126

Parameter	Model: IT-M3126	
Rated value	Voltage	0 ~ 1000V
	Current	0 ~ 3A
	Power	0 ~ 850W
Line Regulation	Voltage	0.004%+30mV
±(% of Output+Offset)	Current	≤0.8mA
Load Regulation	Voltage	0.004%+30mV
±(% of Output+Offset)	Current	≤0.8mA
Setup Resolution	Voltage	100mV
	Current	1mA
	Power	0.1W
Read Back Resolution	Voltage	100mV
	Current	1mA
Setup Accuracy	Voltage	≤0.02% + 0.02%F.S.
	Current	≤0.05% + 0.05%F.S.
	Power	≤0.1%+0.15%F.S.
Read Back Accuracy	Voltage	≤0.02% + 0.02%F.S.
	Current	≤0.05% + 0.05%F.S.

Parameter		Model: IT-M3126
	Power	$\leq 0.1\% + 0.15\% \text{F.S.}$
Ripple (20hz-20Mhz)	Vpp	$\leq 1000\text{mV}$
	Irms	$\leq 5\text{mA}$
Setup Temperature Coefficient	Voltage	$\leq 20\text{PPM}/^\circ\text{C}$
(% of Output+Offset)/ $^\circ\text{C}$	Current	$\leq 50\text{PPM}/^\circ\text{C}$
Read Back Temperature Coefficient	Voltage	$\leq 20\text{PPM}/^\circ\text{C}$
(% of Output+Offset)/ $^\circ\text{C}$	Current	$\leq 50\text{PPM}/^\circ\text{C}$
Rise Time(no load)	Voltage	$\leq 60\text{ms}$
Rise Time(full load)	Voltage	$\leq 150\text{ms}$
Fall Time(no load)	Voltage	$\leq 2\text{S}$
Fall Time(full load)	Voltage	$\leq 200\text{ms}$
Transient Response Time	Voltage	$\leq 1\text{ms}$
AC Input	Voltage	176VAC-264VAC (rated power output)
		99VAC-121VAC (power derating to 750W)
	Frequency	47-63Hz
Setup Stability-30min	Voltage	$0.005\% + 60\text{mV}$
\pm (% of Output+Offset)	Current	$0.01\% + 0.9\text{mA}$
Setup stability-8h	Voltage	$0.005\% + 60\text{mV}$
\pm (% of Output+Offset)	Current	$0.01\% + 0.9\text{mA}$
Readback Stability-30min	Voltage	$0.005\% + 60\text{mV}$
\pm (% of Output+Offset)	Current	$0.01\% + 0.9\text{mA}$
Readback stability-8h	Voltage	$0.005\% + 60\text{mV}$
\pm (% of Output+Offset)	Current	$0.01\% + 0.9\text{mA}$
Efficiency		82%
Remote Sense Compensation Voltage		$\leq 3\text{V}$
Command Response Time		5ms
Power Factor		0.98
Maximum Input Current		10A
Maximum Input Apparent Power		1000VA
Storage Temperature		$-10^\circ\text{C} \sim 70^\circ\text{C}$
Protective Function		OVP/OCP/OTP/OPP/UVP/UCP

Parameter	Model: IT-M3126
	Sense reverse protection
Standard Interface	Optional: RS485 LAN USB CAN
	External analog GPIB
Isolation (output to ground)	1200VDC
Isolation (input to ground)	2200VDC
Working Temperature	0 ~ 40°C
Ingress Protection	IP20
Production Compliance	IEC 61010
Cooling	Air cooling
Dimensions without legs and terminals (mm)	207W*450D*34H
Overall dimension (mm)	234W*505D*58H
Weight(net)	(6±0.5)kg

5.1.23 IT-M3136

Parameter	Model: IT-M3136	
Rated value	Voltage	0 ~ 1000V
	Current	0 ~ 3A
	Power	0 ~ 1500W
Line Regulation	Voltage	0.004%+30mV
±(% of Output+Offset)	Current	≤0.8mA
Load Regulation	Voltage	0.004%+30mV
±(% of Output+Offset)	Current	≤0.8mA
Setup Resolution	Voltage	100mV
	Current	1mA
	Power	0.1W
Read Back Resolution	Voltage	100mV
	Current	1mA
Setup Accuracy	Voltage	≤0.02% + 0.02%F.S.
	Current	≤0.05% + 0.05%F.S.
	Power	≤0.1%+0.15%F.S.
Read Back Accuracy	Voltage	≤0.02% + 0.02%F.S.

Parameter		Model: IT-M3136
	Current	$\leq 0.05\% + 0.05\% \text{F.S.}$
	Power	$\leq 0.1\% + 0.15\% \text{F.S.}$
Ripple (20hz-20Mhz)	Vpp	$\leq 1000\text{mV}$
	Irms	$\leq 5\text{mA}$
Setup Temperature Coefficient	Voltage	$\leq 20\text{PPM}/^\circ\text{C}$
(% of Output+Offset)/ $^\circ\text{C}$	Current	$\leq 50\text{PPM}/^\circ\text{C}$
Read Back Temperature Coefficient	Voltage	$\leq 20\text{PPM}/^\circ\text{C}$
(% of Output+Offset)/ $^\circ\text{C}$	Current	$\leq 50\text{PPM}/^\circ\text{C}$
Rise Time(no load)	Voltage	$\leq 60\text{ms}$
Rise Time(full load)	Voltage	$\leq 150\text{ms}$
Fall Time(no load)	Voltage	$\leq 2\text{S}$
Fall Time(full load)	Voltage	$\leq 200\text{ms}$
Transient Response Time	Voltage	$\leq 1\text{ms}$
AC Input	Voltage	176VAC-264VAC (rated power output)
		99VAC-121VAC (power derating to 750W)
	Frequency	47-63Hz
Setup Stability-30min	Voltage	$0.005\% + 60\text{mV}$
\pm (% of Output+Offset)	Current	$0.01\% + 0.9\text{mA}$
Setup stability-8h	Voltage	$0.005\% + 60\text{mV}$
\pm (% of Output+Offset)	Current	$0.01\% + 0.9\text{mA}$
Readback Stability-30min	Voltage	$0.005\% + 60\text{mV}$
\pm (% of Output+Offset)	Current	$0.01\% + 0.9\text{mA}$
Readback stability-8h	Voltage	$0.005\% + 60\text{mV}$
\pm (% of Output+Offset)	Current	$0.01\% + 0.9\text{mA}$
Efficiency		88%
Remote Sense Compensation Voltage		$\leq 3\text{V}$
Command Response Time		5ms
Power Factor		0.99
Maximum Input Current		12A
Maximum Input Apparent Power		1800VA

Parameter	Model: IT-M3136
Storage Temperature	-10°C ~ 70°C
Protective Function	OVP/OCP/OTP/OPP/UVP/UCP
	Sense reverse protection
Standard Interface	Optional: RS485 LAN USB CAN
	External analog GPIB
Isolation (output to ground)	1200VDC
Isolation (input to ground)	2200VDC
Working Temperature	0 ~ 40°C
Ingress Protection	IP20
Production Compliance	IEC 61010
Cooling	Air cooling
Dimensions without legs and terminals (mm)	207W*450D*34H
Overall dimension (mm)	234W*505D*58H
Weight(net)	(6±0.5)kg

5.2 Supplemental Characteristics

State storage capacity: 10 sets

Recommended calibration frequency: once a year

Cooling style: fans

6 Routine Maintenance

This chapter describes the general maintenance items and maintenance methods of the DC power supply.

- ◆ Instrument Self-Test
- ◆ Cleaning and Maintenance
- ◆ Contact of ITECH Engineers
- ◆ Return for Repair

6.1 Instrument Self-Test

Self-test checks that the minimum set of logic and power mesh systems are functioning properly. Self-test does not enable the output or place any voltages on the output. Self-test can be achieved in two ways:

- Re-start the instrument. Each time the instrument is powered on, the self-test is performed. This test assumes that the instrument is running.
- SCPI command: *TST?. If the return value is 0, the self-test passes; if it is 1, the self-test fails. If the self-test fails, please send command **SYSTem:ER-Ror?** to view the self-test error. Please refer to *IT-M3100 Programming Guide* for the list of error codes.



Note

Ensure that all test cables connections are removed when self-test is performed. During self-test, errors may be induced by signals present on external wiring, such as long test leads that can act as antennae.

6.2 Cleaning and Maintenance

To ensure the safety function and performance of the instrument, please clean and maintain the instrument properly.

WARNING

- **To prevent electrical shock, disconnect the instrument from AC mains power and disconnect all test leads before cleaning.**
 - **Do not use detergent or solvents.**
 - **Do not disassemble the instrument and attempt to clean internally.**
-

Clean the outside and the front panel screen of the instrument using a soft, lint-free, cloth slightly dampened with water. Use a brush to clean the dust on the vent and cooling fans.

6.3 Contact of ITECH Engineers

This section describes operations to be carried out by the user in case of failure of the instrument.

Preparation before contact

When the instrument fails, you should make the following preparations before returning the instrument to ITECH for repair or contacting engineers.

- Check all the items listed in the [Self-inspection of equipment faults](#) and confirm whether there are still some problems.
- Collect the SN of the instrument.
For details, see [Collect the SN number](#).

If there are still some problems, carefully read the **Warranty** and **Limitation of Warranty** in the preface of the manual. Confirm that your instrument complies with warranty service conditions. If after your warranty expires, ITECH offers repair services at competitive prices.

Self-inspection of equipment faults

When the instrument fails, make the following checks to ensure that the failure is in the instrument rather than any external connections. If the instrument failure can be eliminated via simple inspection, the maintenance cost and time can be saved.

- Check whether the AC power cord is securely connected to the instrument and to a powered outlet.
- Check whether the front-panel Power On switch has been pushed.
- Check whether self-inspection of the instrument is successful and whether the specifications and performance are within the indicator ranges.

- Check whether the instrument displays error information.
- Use other instruments instead of this instrument for confirmation.

Collect the SN number

ITECH will constantly improve the product performance, availability and reliability. The service personnel of ITECH will record changes of each instrument. All relevant information is marked uniquely according to the serial number of each instrument. The equipment returned for repair must adopt the SN number as the tracking ID.

When you contact the engineer, the effective SN number of the instrument will be the effective guarantee for effective service and complete information. You can obtain the SN number of the instrument by the following ways:

1. Press **[Shift]+[Save]** (System) to enter into the system menu interface.
2. Use left and right keys or rotate the knob to select **System Info** and press **[Enter]** key.
3. Use left and right keys or knob to view the SN number.

Please record the SN number and provide SN information when doing maintenance service.

How to contact ITECH engineers

Access ITECH official website www.itechate.com or call the service number 4006-025-000 for technical support and services.

6.4 Return for Repair

If your instrument fails during the warranty period, ITECH will repair or replace it under the terms of your warranty. After your warranty expires, ITECH offers repair services at competitive prices. Also you can purchase an extended maintenance service contract that exceeds the standard warranty period.

Get Repair Service

To get the service for your instrument, choose the easiest way to contact the ITECH engineers. ITECH will arrange for repair or replacement of your instrument or provide warranty and repair cost information (if applicable).

Repackaging for Shipment

CAUTION

Never use styrene pellets in any shape as packaging materials. They do not adequately cushion the instrument or prevent it from shifting in the carton. Styrene pellets cause the instrument damage by generating static electricity and by lodging in the rear panel.

ITECH recommends that you retain the original shipping carton for return shipments and always insure shipments. To ship the unit to ITECH for service or repair:

1. Download the **ITECH maintenance service application** from our website, complete it and place it in the box with the instrument.
2. Place the unit in its original container with appropriate packaging material.

If the original shipping container is unavailable, use a container that will ensure at least 10 cm (4 in.) of compressible packaging material around the entire instrument. Use static-free packaging materials.

3. Secure the container with strong tape or metal bands.

A Appendix

◆ Specifications of Red and Black Test Cables

A.1 Specifications of Red and Black Test Cables

ITECH provides you with optional red and black test cables, which are sold individually and you can select for test. For specifications of ITECH test cables and maximum current values, refer to the table below.

Model	Specification
IT-E30110-AB	1kV/10A/1m*2pcs Alligator clips-Banana plugs
IT-E30110-BB	1kV/10A/1m*2pcs Banana plugs-Banana plugs
IT-E30110-BY	1kV/10A/1m*2pcs Banana plugs-Y-type terminals
IT-E30312-YY	500V/30A/1.2m*2pcs Y-type terminals-Y-type terminals
IT-E30320-YY	500V/30A/2m*2pcs Y-type terminals-Y-type terminals
IT-E30615-OO	500V/60A/1.5m*2pcs Ring terminals-Ring terminals
IT-E31005LIC-OO	600V/100A/0.5m*2pcs Ring terminal low inductance
IT-E31010LIC-OO	600V/100A/1m*2pcs Ring terminal low inductance
IT-E31020LIC-OO	600V/100A/2m*2pcs Ring terminal low inductance
IT-E31040LIC-OO	600V/100A/2m*2pcs Ring terminal low inductance
IT-E31220-OO	500V/120A/2m*2pcs Ring terminals-Ring terminals
IT-E31250-OO	500V/120A/5m*2pcs Ring terminals-Ring terminals
IT-E32410-OO	500V/240A/1m*2pcs Ring terminals-Ring terminals
IT-E32420-OO	500V/240A/2m*2pcs Ring terminals-Ring terminals
IT-E32450-OO	500V/240A/5m*2pcs Ring terminals-Ring terminals
IT-E3301020-OO	3kV/100A/2m*2pcs Ring terminals-Ring terminals
IT-E3301050-OO	3kV/100A/5m*2pcs Ring terminals-Ring terminals
IT-E3302420-OO	3kV/240A/2m*2pcs Ring terminals-Ring terminals
IT-E3302450-OO	3kV/240A/5m*2pcs Ring terminals-Ring terminals

IT-E3303620-OO	3kV/360A/2m*2pcs Ring terminals-Ring terminals
IT-E3304020-OO	3kV/400A/2m*2pcs Ring terminals-Ring terminals
IT-E33620-OO	500V/360A/2m*2pcs Ring terminals-Ring terminals
IT-E33650-OO	500V/360A/5m*2pcs Ring terminals-Ring terminals
IT-E34020-OO	500V/400A/2m*2pcs Ring terminals-Ring terminals
IT-E34520-OO	500V/450A/2m*2pcs Ring terminals-Ring terminals
IT-E35030-OO	500V/360A/3m*2pcs Ring terminals-Ring terminals
IT-E36530-OO	500V/650A/3m*2pcs Ring terminals-Ring terminals

For maximum current of AWG copper wire, refer to table below.

AWG	8	10	12	14	16	18	20	22	24	26	28
The Maximum Current Value (A)	60	40	30	20	13	10	7	5	3.5	2.5	1.7



Note

- AWG (American Wire Gage), it means X wire (marked on the wire). The table above lists current capacity of single wire at working temperature of 30°C. For reference only.
- Along with temperature, you must also consider voltage drop when selecting wire sizes.

Although the instrument will compensate for the voltage in the wires, it is recommended to minimize the voltage drop as much as possible to prevent excessive power consumption from the instrument and poor dynamic response to load changes. Larger diameter wire sizes will help minimize wire voltage drops. Twisting or bundling wires will help reduce transient voltage drops.

Connect with us

Thank you for purchasing ITECH products. Any questions, pls. feel free to let us know.

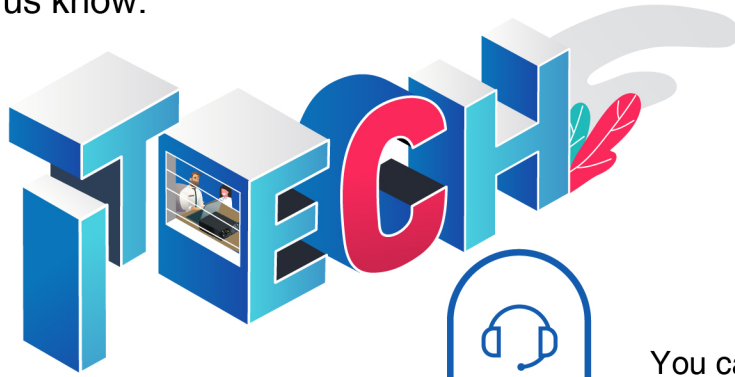

You can chat with us on ITECH website



For more information, pls. visit www.itechate.com



Click and follow ITECH Electronics

