

# Graphical Source Measure Unit

## IT2800 Series User Manual



---

Model: IT2800

Version: V1.3/ 10 , 2025

# Notices

© Itech Electronic, Co., Ltd. 2025

No part of this manual may be reproduced in any form or by any means (including electronic storage and retrieval or translation into a foreign language) without prior permission and written consent from Itech Electronic, Co., Ltd. as governed by international copyright laws.

## Manual Part Number



402225

## Trademarks

Pentium is U.S. registered trademarks of Intel Corporation.

Microsoft, Visual Studio, Windows and MS Windows are registered trademarks of Microsoft Corporation in the United States and/or other countries and regions.

## Warranty

The materials contained in this document are provided “as is”, and is subject to change, without prior notice, in future editions. Further, to the maximum extent permitted by applicable laws, ITECH disclaims all warranties, either express or implied, with regard to this manual and any information contained herein, including but not limited to the implied warranties of merchantability and fitness for a particular purpose. ITECH shall not be held liable for errors or for incidental or indirect damages in connection with the furnishing, use or application of this document or of any information contained herein. Should ITECH and the user enter into a separate written agreement with warranty terms covering the materials in this document that conflict with these terms, the warranty terms in the separate agreement shall prevail.

## Technology Licenses

The hardware and/or software described herein are furnished under a license and may be used or copied only in accordance with the terms of such license.

## Restricted Rights Legend

Restricted permissions of the U.S. government. Permissions for software and technical data which are authorized to the U.S. Government only include those for custom provision to end users. ITECH follows FAR 12.211 (technical data), 12.212 (computer software). DFARS 252.227-7015 (technical data—commercial products) and DFARS 227.7202-3 (permissions for commercial computer software or computer software documents) while providing the customized business licenses of software and technical data.

## Safety Notices

### CAUTION

A CAUTION sign denotes a hazard. It calls attention to an operating procedure or practice that, if not correctly performed or adhered to, could result in damage to the product or loss of important data. Do not proceed beyond a CAUTION sign until the indicated conditions are fully understood and met.

### WARNING

A WARNING sign denotes a hazard. It calls attention to an operating procedure or practice that, if not correctly performed or adhered to, could result in personal injury or death. Do not proceed beyond a WARNING sign until the indicated conditions are fully understood and met.



### Note

A NOTE sign denotes important hint. It calls attention to tips or supplementary information that is essential for users to refer to.

## Quality Certification and Assurance

We certify that series instrument meets all the published specifications at time of shipment from the factory.

## Warranty

ITECH warrants that the product will be free from defects in material and workmanship under normal use for a period of one (1) year from the date of delivery (except those described in the Limitation of Warranty below).



### Note

Visit <https://www.itechate.com/en/support/register.html> to complete product registration by filling out the necessary information to extend the warranty to two (2) years.

For warranty service or repair, the product must be returned to a service center designated by ITECH.















- The product returned to ITECH for warranty service must be shipped PRE-PAID. And ITECH will pay for return of the product to customer.
- If the product is returned to ITECH for warranty service from overseas, all the freights, duties and other taxes shall be on the account of customer.

## Limitation of Warranty

This Warranty will be rendered invalid in case of the following:

- Damage caused by circuit installed by customer or using customer own products or accessories;
- Modified or repaired by customer without authorization;
- Damage caused by circuit installed by customer or not operating our products under designated environment;
- The product model or serial number is altered, deleted, removed or made illegible by customer;
- Damaged as a result of accidents, including but not limited to lightning, moisture, fire, improper use or negligence.

## Safety Symbols

	Direct current		ON ( power)
	Alternating current		OFF ( power)
	Both direct and alternating current		Power-on state
	Chassis (earth ground) symbol.		Power-off state
	Earth ( ground) terminal		Reference terminal
	Caution		Positive terminal
	Warning ( refer to this manual for specific Warning or Caution information)		Negative terminal
	A chassis terminal	-	-

## Safety Precautions

The following safety precautions must be observed during all phases of operation of this instrument. Failure to comply with these precautions or specific warnings elsewhere in this manual will constitute a default under safety standards of design, manufacture and intended use of the instrument. ITECH assumes no liability for the customer's failure to comply with these precautions.

**WARNING**

- **Do not use the instrument if it is damaged. Before operation, check the casing to see whether it cracks. Do not operate the instrument in the presence of inflammable gasses, vapors or dusts.**
  - **The instrument is provided with a power cord during delivery and should be connected to a socket with a protective earth terminal, a junction box or a three-phase distribution box. Before operation, be sure that the instrument is well grounded.**
  - **Please always use the provided cable to connect the instrument.**
  - **Check all marks on the instrument before connecting the instrument to power supply.**
  - **Ensure the voltage fluctuation of mains supply is less than 10% of the working voltage range in order to reduce risks of fire and electric shock.**
  - **Do not install alternative parts on the instrument or perform any unauthorized modification.**
  - **Do not use the instrument if the detachable cover is removed or loosen.**
  - **To prevent the possibility of accidental injuries, be sure to use the power adapter supplied by the manufacturer only.**
  - **We do not accept responsibility for any direct or indirect financial damage or loss of profit that might occur when using the instrument.**
  - **This instrument is used for industrial purposes, do not apply this product to IT power supply system.**
  - **Never use the instrument with a life-support system or any other equipment subject to safety requirements.**
-

**WARNING**

- **SHOCK HAZARD Ground the Instrument.** This product is provided with a protective earth terminal. To minimize shock hazard, the instrument must be connected to the AC mains through a grounded power cable, with the ground wire firmly connected to an electrical ground (safety ground) at the power outlet or distribution box. Any interruption of the protective (grounding) conductor or disconnection of the protective earth terminal will cause a potential shock hazard that could result in injury or death.
  - **Before applying power, verify that all safety precautions are taken.** All connections must be made with the instrument turned off, and must be performed by qualified personnel who are aware of the hazards involved. Improper actions can cause fatal injury as well as equipment damage.
  - **SHOCK HAZARD, LETHAL VOLTAGES** This product can output the dangerous voltage that can cause personal injury, and the operator must always be protected from electric shock. Ensure that the output electrodes are either insulated or covered using the safety covers provided, so that no accidental contact with lethal voltages can occur.
  - **Never touch cables or connections immediately after turning off the instrument.** Verify that there is no dangerous voltage on the electrodes or sense terminals before touching them.
  - **After using the device, turn off the power switch of the device before unplugging the power cord or disassembling the terminals.** Do not touch the cable or the terminal immediately. Depending on the model, the dangerous voltage at the plug or terminal is maintained for 10 seconds after the device is switched off. Make sure that there is no dangerous voltage before touching them.
- 

**CAUTION**

- **Failure to use the instrument as directed by the manufacturer may render its protective features void.**
  - **Always clean the casing with a dry cloth. Do not clean the internals.**
  - **Make sure the vent hole is always unblocked.**
- 

## Environmental Conditions





The instrument is designed for indoor use and an area with low condensation. The table below shows the general environmental requirements for the instrument.

Environmental Conditions	Requirements
Operating temperature	0°C ~ 40°C
Operating humidity	20% ~ 80%( non-condensation)
Storage temperature	-10°C ~ 70 °C
Altitude	Operating up to 2,000 meters
Installation category	II
Pollution degree	Pollution degree 2



**Note**

In order to ensure the accuracy of measurement, it is recommended to operate the instrument half an hour after start-up.

## Regulation Tag

	The CE tag shows that the product complies with the provisions of all relevant European laws (if the year is shown, it indicates that the year when the design is approved).
	The UKCA tag shows that the product complies with the provisions of all relevant United Kingdom laws (if the year is shown, it indicates that the year when the design is approved).
	This instrument complies with the WEEE directive (2002/96/EC) tag requirements. This attached product tag shows that the electrical/electronic product cannot be discarded in household waste.
	This symbol indicates that no danger will happen or toxic substances will not leak or cause damage in normal use within the specified period. The service life of the product is 10 years. The product can be used safely within the environmental protection period; otherwise, the product should be put into the recycling system.

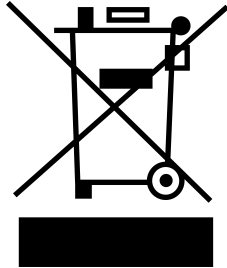
## Waste Electrical and Electronic Equipment (WEEE) Directive



Waste electrical and electronic equipment (WEEE) directive, 2002/96/EC

The product complies with tag requirements of the WEEE directive (2002/96/EC). This tag indicates that the electronic equipment cannot be disposed of as ordinary household waste. Product Category

According to the equipment classification in Annex I of the WEEE directive, this instrument belongs to the "Monitoring" product.

If you want to return the unnecessary instrument, please contact the nearest sales office of ITECH.



## Compliance Information

Complies with the essential requirements of the following applicable European Directives, and carries the CE marking accordingly:

- Electromagnetic Compatibility (EMC) Directive 2014/30/EU
- Low-Voltage Directive (Safety) 2014/35/EU

Conforms with the following product standards:

### EMC Standard

IEC 61326-1 / EN 61326-1 <sup>123</sup>

#### Reference Standards

CISPR 11, Class A

IEC 61000-3-2

IEC 61000-3-3

IEC 61000-4-2

IEC 61000-4-3

IEC 61000-4-4

IEC 61000-4-5

IEC 61000-4-6

IEC 61000-4-11

1. The product is intended for use in non-residential/non-domestic environments. Use of the product in residential/domestic environments may cause electromagnetic interference.
2. Connection of the instrument to a test object may produce radiations beyond the specified limit.
3. Use high-performance shielded interface cable to ensure conformity with the EMC standards listed above.

### Safety Standard

IEC 61010-1:2010+A1:2016



#### Note

This section provides general and universal terms. For more detailed information on the *Declaration of Conformity*, please contact ITECH personnel.

## Content

Quality Certification and Assurance .....	I
Warranty .....	I
Limitation of Warranty .....	I
Safety Symbols .....	II
Safety Precautions.....	II
Environmental Conditions.....	IV
Regulation Tag.....	V
Waste Electrical and Electronic Equipment (WEEE) Directive .....	VI
	
Compliance Information .....	VII
1 Quick Reference.....	1
1.1 Brief Introduction.....	1
1.2 Front-Panel Overview .....	2
1.3 Home-Screen Overview.....	4
1.4 Icon Reference.....	5
1.5 Rear-Panel Overview.....	8
1.6 Menu Overview .....	10
1.6.1 Meter.....	11
1.6.2 Scope.....	16
1.6.3 Recorder .....	20
1.6.4 Sweep.....	25
1.6.5 Meas ohms .....	27
1.6.6 Meas limit.....	28
1.6.7 Meas math .....	34
1.6.8 System.....	37
1.6.9 Config .....	41
1.6.10 Battery .....	45
1.6.11 Save / Recall.....	49
1.7 Models and Options.....	50
2 Inspection and Installation.....	59
2.1 Verifying the Shipment.....	59
2.2 Instrument Size Introduction .....	60
2.3 Rack Installation.....	62
2.4 Connecting the Power Cord.....	63
2.5 Connecting the Device Under Test (DUT) .....	65
2.6 Remote Interface Connection .....	80
2.6.1 USB Interface .....	80
2.6.2 LAN Interface.....	81
2.6.3 GPIB Interface (Optional) .....	85
3 Function Details.....	86
3.1 Scope Mode .....	86
3.2 Recorder Mode .....	93
3.3 Measure Limit.....	100
3.4 Battery Simulation.....	107
3.5 Synchronous On/Off Function .....	119
3.6 Protection Functions in Detail .....	121
3.7 Sweep Function .....	122
3.8 Config Menu Function.....	134
3.9 Meas ohms Function.....	143
3.10 Meas math Function .....	144
3.11 Trace Function .....	149
3.12 Trigger Function.....	153
3.13 Fiber Optic Synchronization Trigger Function .....	155

4	Technical Specification.....	162
4.1	Main Specification.....	162
4.1.1	IT2801.....	162
4.1.2	IT2805.....	166
4.1.3	IT2806.....	171
4.1.4	IT2801R.....	177
4.1.5	IT2805R.....	181
4.1.6	IT2806R.....	186
4.2	Supplemental Characteristics.....	191
5	Routine Maintenance.....	192
5.1	Instrument Self-Test.....	192
5.2	Cleaning and Maintenance.....	192
5.3	Contact of ITECH Engineers.....	193
5.4	Return for Repair.....	194

# 1 Quick Reference

This chapter briefly introduces the front panel, rear panel, keyboard button functions and front panel display functions of this series instrument to ensure a quick understanding of the appearance, structure and key usage features of the instrument before operating the instrument. This chapter does not introduce each operating characteristics in detail. It is just a quick reference guide to help you quickly learn the operating characteristics of the instrument.

- ◆ [Brief Introduction](#)
- ◆ [Front-Panel Overview](#)
- ◆ [Home-Screen Overview](#)
- ◆ [Icon Reference](#)
- ◆ [Rear-Panel Overview](#)
- ◆ [Menu Overview](#)
- ◆ [Models and Options](#)

## 1.1 Brief Introduction

The IT2800 Series are compact and cost-effective bench-top Source Measure Units (SMUs) with the capability to source and measure both voltage and current. These capabilities make the IT2800 Series ideal for a wide variety of IV (current versus voltage) measurement tasks that require both high resolution and accuracy.

Performance and functions:

- 5 inch touch display supports both graphical and numerical view modes.
- Combining the capabilities of six devices in one: Voltage Source, Current Source, 6 ½ Digital Multimeter (DCV,DCI, ohms), Battery Simulator, electronic load and Pulse Generator
- Integrating 4-quadrant sourcing & measuring capabilities, and supporting Two-wire & Four-wire measurement
- Resolution up to 10fA/100nV, sampling rate up to 10us.
- Built-in battery simulator function, suitable for IOT low power precision measurement
- Sweep Capability: Linear/Log/ Pulsed-line AR/Pulsed-Log and LIST
- Multi-channel and simultaneous operation design, with parallel testing capability
- Built-in resistance, power, and Math measurement features
- With GUARD output function, suitable for low current measurement

- Front USB port used for data storage, screen capture, or test configuration import
- Built-in Digital IO/USB/LAN communication interface

## 1.2 Front-Panel Overview

The detailed front panel of the IT2800 series instruments is described below.

- IT2801



- IT2806



Name	Description
USB-A port	Saves reading buffer data and screen snapshots to a USB flash drive ( <b>Menu</b> → <b>System</b> → <b>Communication</b> → <b>USB Type</b> must be set to <b>Host</b> ). The flash drive must be formatted as a FAT32 drive. After disconnecting the USB memory, wait 10 seconds before connecting it again or new one. <b>Turning the instrument off while the USB memory is being accessed may damage the device.</b>
<b>[View]</b>	Used to change the display mode. Press the <b>[View]</b> key to enter the oscilloscope interface. Press the <b>[View]</b> key again to enter the Meter measurement interface.
<b>[Trig]</b>	Manually trigger function keys. When the trigger source is changed to Manual, you can start a single measurement or trigger Sweep to run.
<b>[Menu]</b>	Menu function button.
Power Switch	Turn on or off the power switch of the instrument.
Touchable display	The 5-inch touch screen can display source meter settings, measurement results, status information, etc. Operations involving parameter setting or selection can be set by clicking on the touch screen, or by using the function buttons on the right side combined with the knob.
<b>[On/Off]</b>	Turns the power output on or off. When this button is lit, the output is on.
<b>[Shift]</b> key	Composite function keys that combine with other keys to achieve the function labeled above the key.
<b>[V-set]</b> (Config)	<ul style="list-style-type: none"> <li>• Voltage setting button.</li> <li>• Key combination. Use the <b>[Shift]</b> then <b>[V-set]</b> keys to access the Config menu.</li> </ul>
<b>[I-set]</b> (Sweep)	<ul style="list-style-type: none"> <li>• Current setting button.</li> <li>• Key combination. Use the <b>[Shift]</b> then <b>[I-set]</b> keys to enter Sweep interface.</li> </ul>
<b>[Esc]</b> (Local)	<ul style="list-style-type: none"> <li>• Exit / Undo key</li> <li>• Key combination. In remote programmable operation, use the <b>[Shift]</b> then <b>[Esc]</b> keys to switch the instrument to local operation mode.</li> </ul>
<b>[Enter]</b> (Print)	<ul style="list-style-type: none"> <li>• Confirm button</li> </ul>

Name	Description
	<ul style="list-style-type: none"> <li>Key combination. Use the <b>[Shift]</b> then <b>[Enter]</b> keys to take a screenshot and save the image as a bmp file.</li> </ul>
Pressable knob	<ul style="list-style-type: none"> <li>Turn the knob to adjust the voltage or current value, or turn the page to display the menu item. Turn clockwise to increase the set value and counterclockwise to decrease the set value; after entering the menu interface, turn the knob to turn the page to display the menu items.</li> <li>Press the knob. Equivalent to the <b>[Enter]</b> key.</li> </ul>
Left and right arrow keys	Use the left and right arrow keys to move the cursor below a number, or to move to select a setting item.
Output / Measurement terminals	Terminals for SMU channel. High Force, Low Force, High Sense, Low Sense, Guard, and chassis ground. For details, see <a href="#">2.5 Connecting the Device Under Test (DUT)</a> . <b>Attention: Never connect the Guard terminal to any output, including circuit common, chassis ground, or any other guard terminal. Doing so will damage the instrument.</b>

## 1.3 Home-Screen Overview

IT2800series SMUs run a self-test automatically when it is powered on. If the self-test finishes with no errors, the screen below is displayed.

































No.	Name	Description
1	Status display area	Displays information such as the instrument's measurement range or status.
2	Measured value display area	The measured values are displayed in real time. The upper row is for the primary measurement data and the lower row is for the secondary measurement data.
3	Measurement trigger mode (Auto/Manual)	<ul style="list-style-type: none"> <li>Continue &amp; Measure (Auto): Automatically and continuously refreshes the Meter value.</li> <li>Manual Trigger Mode (Manual): Manual triggering is required, and the trigger signal of the Trig button must be received before refreshing the Meter value.</li> </ul>
4	Setting value editing area	Set the voltage value and current value. You can change these values by pressing the <b>[V-set]</b> and <b>[I-set]</b> keys on the front panel.
5	Range selection area	Select the measurement range.























## 1.4 Icon Reference

This series of instruments provides detailed prompt information during operation to facilitate users to understand the instrument functions during use.

- **Icon Introduction**

Icon	Description	Icon	Description
	Output off state		The output is on and in CV constant voltage mode.
	The output is on and in CC constant current mode.		<b>Config</b> configuration menu
	Battery simulation function is enabled		Sense function is turned on
	Recorder function is turned on		Resistance measurement function is turned on

Icon	Description	Icon	Description
	Composite limit test function is turned on		Math calculation function is turned on
	Pulse mode is turned on		Waiting for the trigger to run Sweep
	Sweep is running		The interlock terminal is open. At this time, the voltage setting value is less than or equal to $\pm 42V$ , and cannot be set greater than $\pm 42V$ .
	Interlock terminal short-circuit state. The voltage setting can exceed $\pm 42V$ at this time, up to the rated voltage value.		The instrument is under remote control.
	The instrument recognizes that the USB flash drive is inserted.		High capacitance mode is turned on.
	Multi-master fault indication		Fiber optic communication anomaly
	Disable output. This fault indication pops up when the output is greater than 42V and the Interlock becomes open.		Overcurrent protection status
	Over temperature protection status		Overvoltage protection status
	Sense abnormal protection status		Communication command error
	Voltage measurement in the 1000V range (- only IT2801 models are available)		Voltage measurement in the 200V range
	Voltage measurement in the 20V range		Voltage measurement in the 2V range

Icon	Description	Icon	Description
	Voltage measurement in the 200mV range		Current measurement in 10A range (only IT2806 pulse mode available)
	Current measurement in 3A range (only IT2806 available)		Current measurement in 1A range
	Current measurement in 100mA range		Current measurement in 10mA range
	Current measurement in 1mA range		Current measurement in 100uA range
	Current measurement in 10uA range		Current measurement in 1uA range
	Current measurement in 100nA range (only IT2805 and IT2806 available)		Current measurement in 10nA range (only IT2805 and IT2806 available)
	Resistance measurement in the 200MΩ range (only IT2805 and IT2806 available)		Resistance measurement in the 20MΩ range
	Resistance measurement in the 2MΩ range		Resistance measurement in the 200kΩ range
	Resistance measurement in the 20kΩ range		Resistance measurement in the 2kΩ range
	Resistance measurement in the 200Ω range		Resistance measurement in the 20Ω range
	Resistance measurement in the 2Ω range		SMU is set as Master
	SMU is set as Slave	-	

## 1.5 Rear-Panel Overview

The IT2800 Series SMU detailed rear panel description is shown below.

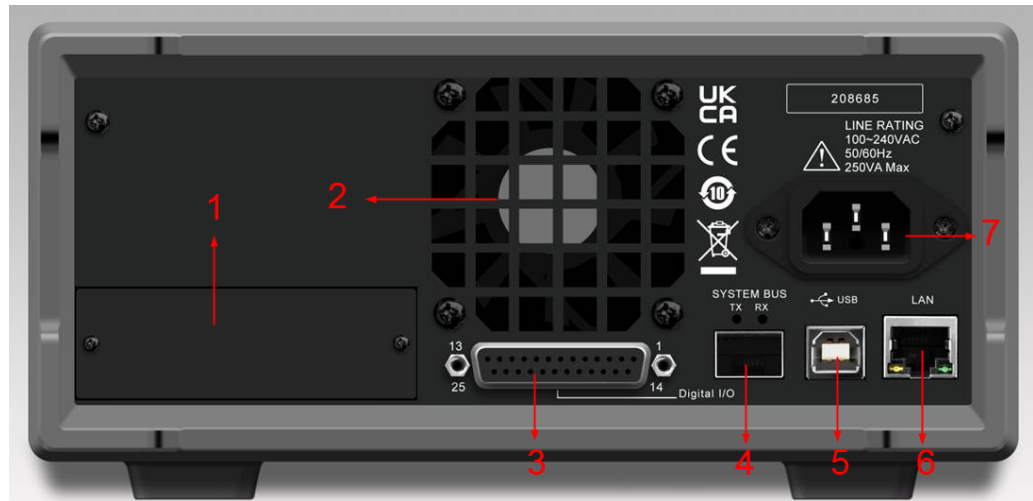

The detailed rear panel introduction of IT2800R series SMU is as follows.

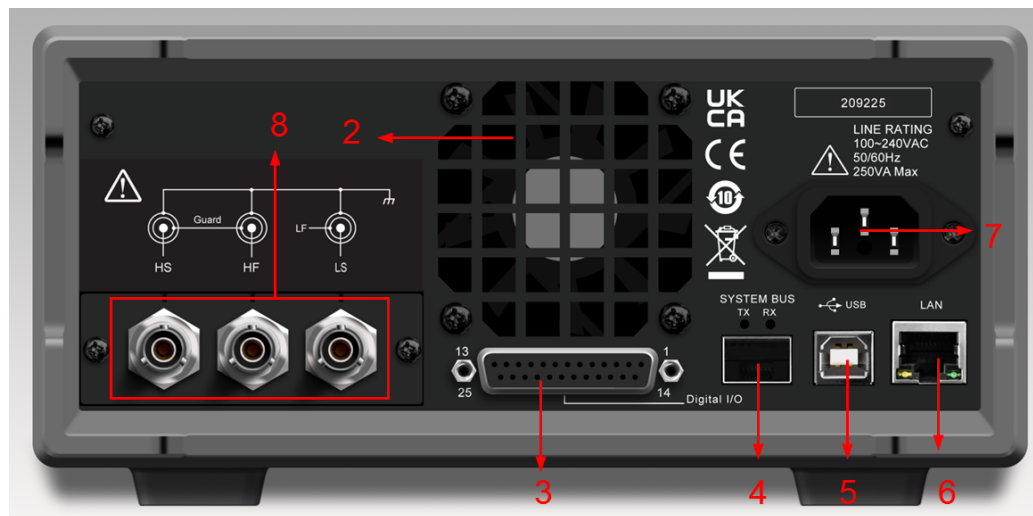

No.	Name	Description
1	Optional expansion slot	Optional interfaces: (The baffle is installed by default when the user does not purchase the interface.) <ul style="list-style-type: none"> <li>IT-E176: GPIB communication card</li> </ul> <b>Note: IT2800R series does not support this communication board.</b>
2	Smart fan outlet	This is the cooling fan outlet, please do not cover or block it.
3	Digital I/O terminals	Rear panel digital IO terminals. For detailed pin function descriptions, see <a href="#">Digital I/O instruction</a> .

No.	Name	Description
4	Fiber optic socket interface (TX and RX)	For communication between multiple SMUs, suitable for multi-channel and synchronous operation.
5	USB-B communication interface	USB-B type interface, supporting both USBTMC and USBVCP options. And, the <b>Menu</b> → <b>System</b> → <b>Communication</b> → <b>USB Type</b> must be set to <b>Device</b> .
6	LAN communication interface	Used for LAN communication.
7	AC power input interface	The AC power cord is connected to this outlet and supports 100~240VAC input.
8	BNC terminals on the rear panel of IT2800R series	Used to connect low-leakage triax cable IT-E801C-1.5 or IT-E802C-1.5. <b>Note: Only available in IT2800R series.</b>

## Digital I/O instruction

The pins of Digital I/O are described as follows.



Pin	Description
1~16	Digital I/O pins, specific function reference <a href="#">1.6.8 System</a> .
17~20	GND
21 and 22	Inter Lock Control (output interlock terminal), shorting these 2 pins, the device can set and output more than $\pm 42V$ ; otherwise, it only supports setting and outputting $\pm 42V$ and below.
23~25	+5V reference voltage pin. Can be used to provide 5V high level control signal to Digital I/O pins 1~16.

## Digital IO Characteristics

Maximum input voltage	15V	Pin1-pin16 : Digital I/O
Typical input voltage	5V	

Minimum input voltage	0V	
Minimum logic high level	2V	
Maximum logic low level	0.8V	
Maximum output current	0.5mA @Vout = 0V	
Maximum sink current	20mA@Vout = 5V	
IO high level fall time	less than 1us	
IO low level rising time	less than 5us	
IO minimum output pulse width (trig out)	10us	
IO minimum detection pulse width (trig in)	10us	
+5V	500mA	pin23-pin25: +5V reference voltage pin

## 1.6 Menu Overview

When the **[Menu]** button in the lower left corner of the instrument is pressed, the button lights up and the screen displays as follows.

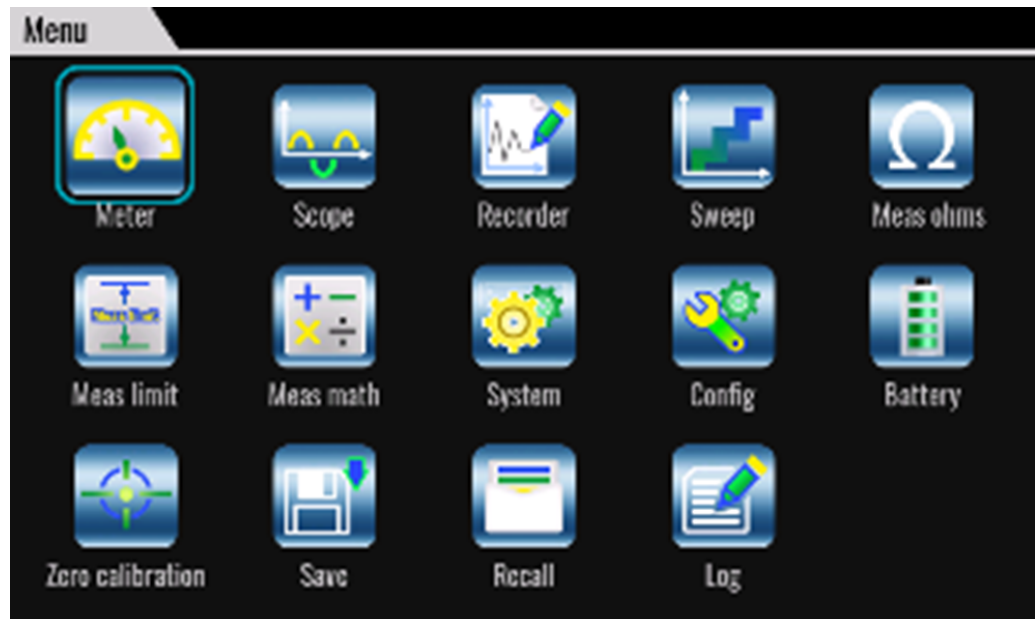

## 1.6.1 Meter

### Function Introduction

For an introduction to the interface, see [1.3 Home-Screen Overview](#).

The IT2800 supports the following measurement parameters. The measurement parameters displayed in the actual interface are associated with the settings of **Menu**→**Config**→**Measure**→**View Type**.

- Current
- Voltage
- Resistance
- Power

Resistance data is given by  $\text{Resistance} = V_{\text{meas}}/I_{\text{meas}}$ .

Power data is given by  $\text{Power} = V_{\text{meas}} * I_{\text{meas}}$ .

In the above formula,  $V_{\text{meas}}$  is the voltage measurement data, and  $I_{\text{meas}}$  is the current measurement data.

### Parameter Setting

The Meter interface also supports the setting of voltage and current values, as well as the selection of voltage and current ranges.

#### Voltage value setting:

Based on the **Menu**→**Config**→**Source Mode** setting is **Volts** (Voltage source mode) or **Amps** (Current source mode), the Meter interface will display the voltage setting as **V-set** or **V Limit**.

The setup method is as follows.

- Method 1: Set by knob and button combination
  1. Turn the knob or press the left/right key in the Meter screen until the parameter area is selected.
  2. Press the **[Enter]** key.

The cursor flashes at this point, indicating that the parameter is in the state to be modified, as shown in the following figure.



3. Press the left/right key to move the cursor position and turn the knob to adjust the value.
  4. Press the **[Enter]** key to confirm the setting.
- Method 2: Setting by tapping the touch screen
    1. Touch the voltage value setting area next to **V-set** or **V Limit** with your finger.

The cursor flashes at this point, indicating that the parameter is in the state to be modified, as shown in the following figure.



2. Touch the area again with your finger.

The screen pops up with the soft keyboard screen for voltage setting as shown in the following figure.



3. Touch the number on the screen with your finger to set it.
4. Touch the **[Enter]** key on the screen with your finger to confirm the setting.

#### Current value setting.

Based on the **Menu**→**Config**→**Source Mode** setting is **Volts** (Voltage source mode) or **Amps** (Current source mode), the Meter interface will display the current setting as **I Limit** or **I-set**.

The setup method is as follows.

- Method 1: Set by knob and button combination

1. Turn the knob or press the left/right key in the Meter screen until the parameter area is selected.
2. Press the **[Enter]** key.

The cursor flashes at this point, indicating that the parameter is in the state to be modified, as shown in the following figure.



3. Press the left/right key to move the cursor position and turn the knob to adjust the value.
  4. Press the **[Enter]** key to confirm the setting.
- Method 2: Setting by tapping the touch screen

1. Touch the current value setting area next to **I-set** or **I Limit** with your finger.

The cursor flashes at this point, indicating that the parameter is in the state to be modified, as shown in the following figure.



2. Touch the area again with your finger.

At this time, the screen pops up the soft keyboard interface for current setting, as shown in the following figure.



3. Touch the number on the screen with your finger to set it.
4. Touch the **[Enter]** key on the screen with your finger to confirm the setting.

#### Voltage range selection:

Touch the corresponding area with your finger or turn the knob to select the corresponding area and then press **[Enter]**, the screen will be displayed as shown below. The user can select the corresponding range according to the test requirements.

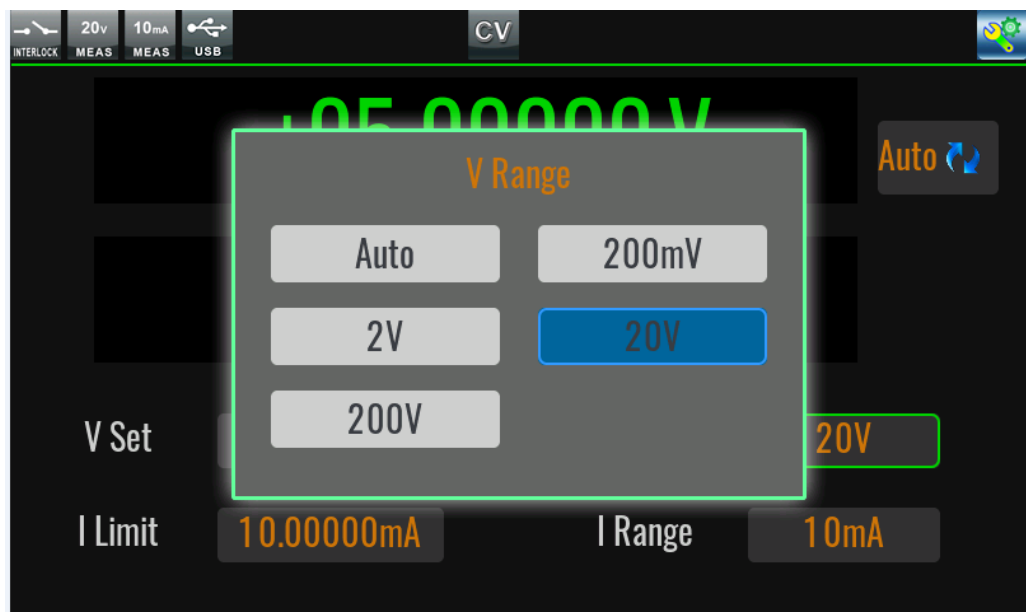



**Note**

The range options displayed vary from model to model.

**Current range selection:**

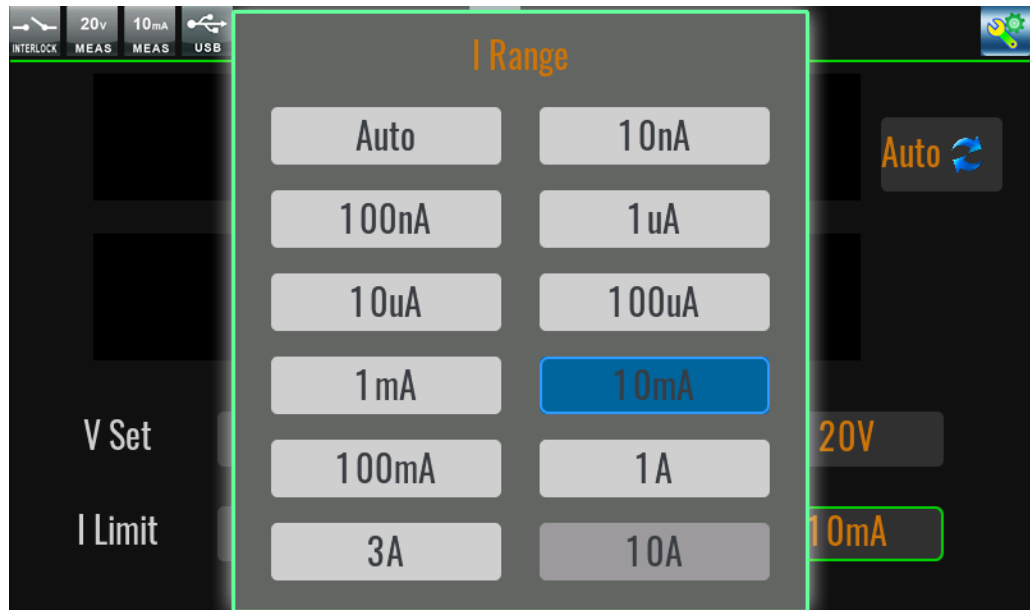
Touch the corresponding area with your finger or turn the knob to select the corresponding area and then press **[Enter]**, the screen will be displayed as shown below. The user can select the corresponding range according to the test requirements.

**Note**

The range options displayed vary from model to model.

## 1.6.2 Scope

Scope interface is used to capture voltage and current data in real time during high-speed operation and plot these data into waveform curves, which supports generating .csv format files and exporting to a USB flash drive.

To access the Scope interface:

- Press the **[View]** key on the left side of the instrument.
- Press the **[Menu]** key to enter **Menu**→**Scope**.

The interface features are described as follows.

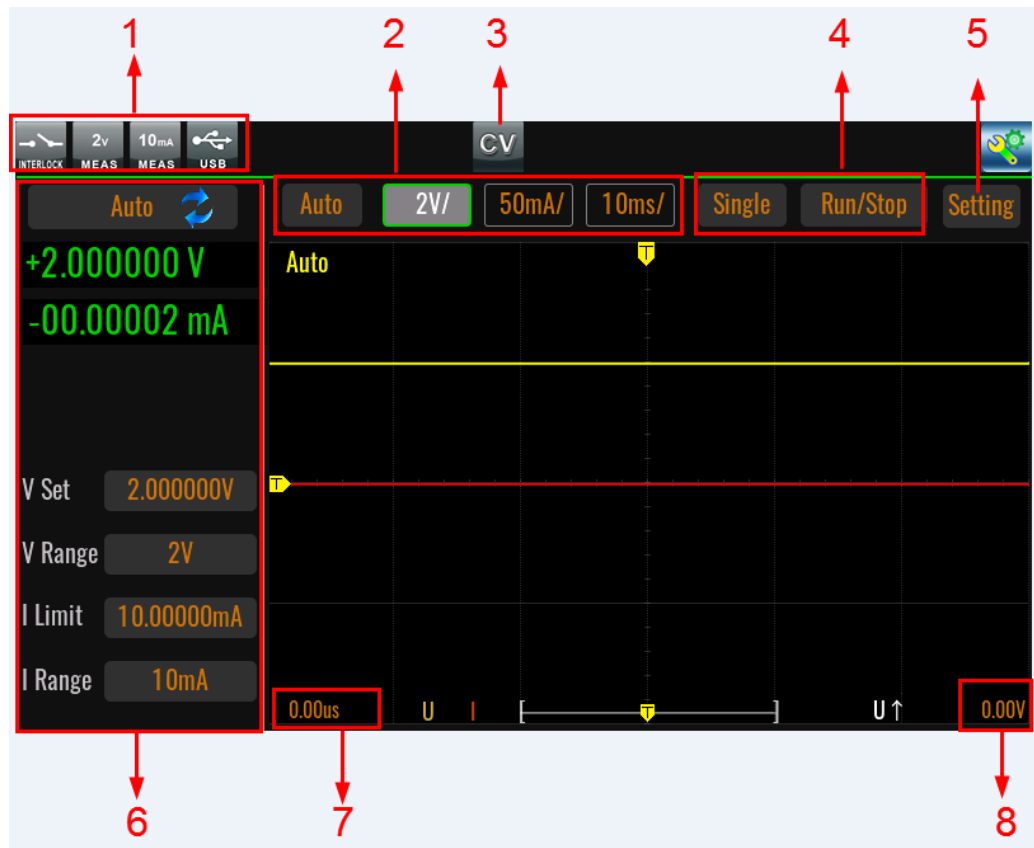

1. Display the voltage range, current range, interlock status, U disk identification status
2. Adjusts the resolution of the X or Y axis oscilloscope function.
  - Auto: Changes graph scale to fit the trace in the graph automatically. Pressing the **[Auto]** key at the touch screen will adaptively display the waveform and restore the X and Y axis offset values to 0, which is where Figure Note 7 and Figure Note 8 are.
  - 2V/ and 1A/: Y-axis scale per division V/div., A/div.
  - 10ms: X-axis scale per division ms/div.

### Note

You can also zoom in and out on the X-axis by dragging the touch screen with two fingers inward or outward at the same time. Once the default X-axis scale per division 50ms/div is modified, the yellow Auto status in the upper left corner is replaced with Roll.

Setting method: Press the corresponding area of the touch screen (or turn the knob until the area is selected and then press **[Enter]**) to put the parameter into the state to be set, as shown below, then turn the knob or press the left/right arrow keys to adjust it, and then press **[Enter]** to confirm.



3. Output status display
4. Measurement method of the oscillometric function:
  - Single: Single measurement
  - Run / Stop: Continuous measurement
5. Setting: Press the corresponding area of the touch screen (or turn the knob until the icon is selected and then press **[Enter]**) to display the screen as follows.

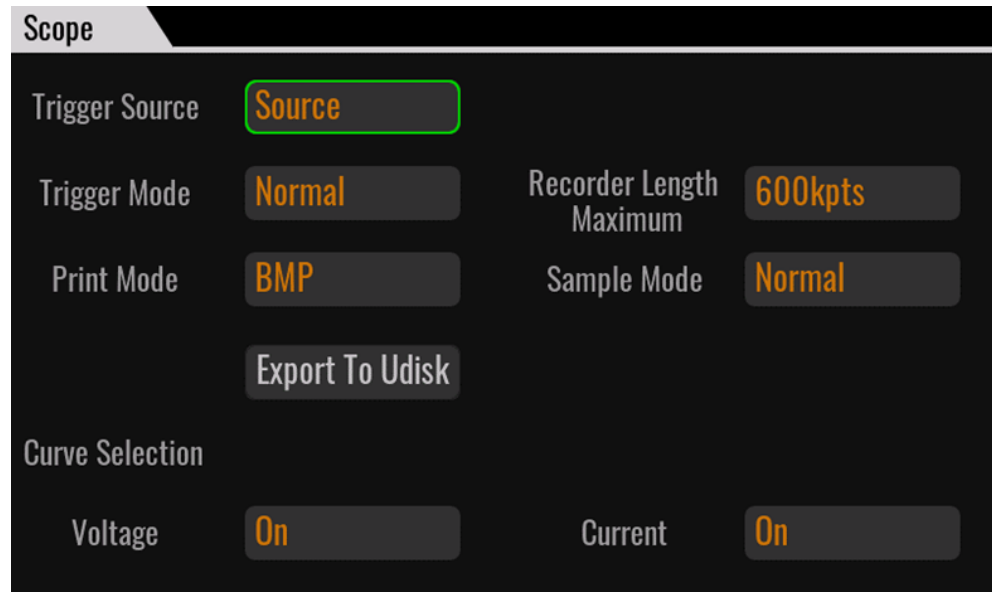

- Trigger Source: Select the trigger source for the oscilloscope function

Item	Description
Source	Source change trigger. It indicates that a trigger signal is generated whenever any set output value is changed.
Voltage	Voltage triggered
Current	Current triggered
Manual	<b>[Trig]</b> key triggered
Bus	* <b>TRG</b> command triggered
Trigger-1	Digital I/O Trigger-1 triggered (Default 0V low level in effect)
Trigger-2	Digital I/O Trigger-2 triggered (Default 0V low level in effect)
Fiber-1	Fiber optic triggered (multi-channel use)

- Trigger Edge: Trigger edge
- Trigger Mode: Trigger mode
  - In Normal mode: voltage range, current range, time base, time offset, configured according to user set values.
  - Auto mode: Setting the **Trigger Mode** to **Auto** means that the trigger is automatically generated according to the **Time Div** timing.
- Recorder Length Maximum: the maximum acquisition depth
- Print Mode: Under the oscilloscope interface, select the file format for saving measurement data to a USB flash drive.
  - BMP: Press **[Shift] then [Enter]** (Print) keys to save the data as a screenshot file in .bmp format to a USB flash drive.
  - BMP&Data: Press **[Shift] then [Enter]** (Print) keys to save the data to the U disk in .csv and .bmp format files.
- Export To Udisk: Insert the USB disk, and press **Enter**, confirm according to the interface prompts, and you can export the acquisition data to U disk. Exporting to .csv format file is supported. The file is as shown below.

Model:IT2806		
Sn:805198011786870004		
Voltage div:2.000000V		
Current div:0.000200A		
Time div:0.010000s		
Delay:0.003600s		
Sample interval:10.0us		
Trigger index:2640		
No	Voltage(V)	Current(A)
0	1.60097	0.0996529
1	1.60108	0.0995631
2	1.60076	0.0995093

- Sample Mode: Set the sampling mode, with options for **Normal** or **Peak**. This option can only be edited when **Recorder Length Maximum** is set to **600kpts**; for other values, only **Normal** can be selected.
  - Curve Selection: Choose to display the waveform type as voltage, current or voltage and current.
 

Select On to display the corresponding waveform, and select Off to not display it.
6. Same as Meter interface for parameter setting and measurement value display.
  7. X-axis offset value
 

The yellow T icon displayed on the X-axis indicates the trigger moment.

To set: Press the corresponding area of the touch screen (or turn the knob until the area is selected and then press **[Enter]**), and then turn the knob to adjust.

#### 8. Y-axis offset value

The yellow T icon on the Y-axis indicates the voltage or current trigger value.

To set: Press the corresponding area of the touch screen (or turn the knob until the area is selected and then press **[Enter]**), and then turn the knob to adjust.



#### Note

Adjusting this parameter is supported only when the **Scope**→**Setting**→**Trigger Source** is selected as **Voltage** or **Current**.

## 1.6.3 Recorder

This function is used to record the voltage measurement value, current measurement value, power measurement value, resistance measurement value, source output value, and mathematical calculation value during the test operation, and draw these data into easy-to-observe curves or generate .csv / The file in .tdms format is exported to the U disk.

To access the Recorder interface:

Press the **[Menu]** key, enter **Menu**→**Recorder**.

The interface features are described as follows.

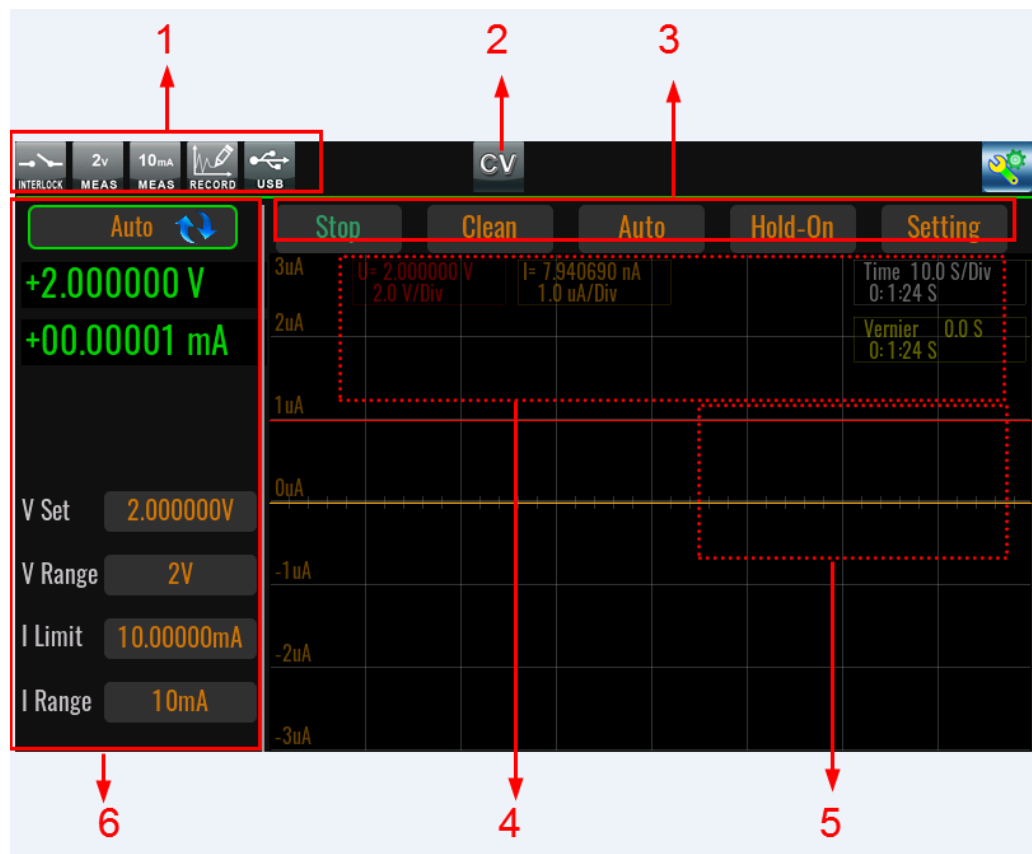

1. Display voltage range, current range, interlock status, Recorder run/stop status, U disk recognition status
2. Output status display
3. Recorder function menu bar.
  - Run / Stop: Runs or stops data logging. After running the Recorder function, a status marker for the start of data recording will appear at the top left of the screen.

### Note

Click Stop to stop recording and then Run, the screen will clear the data first and then redraw the curve.

- Clean: Clear the currently drawn graph (the original data still exists). If Clean is executed during Run, recording will automatically restart.
- Setting: More settings. After entering Setting interface, the parameters are introduced as follows.

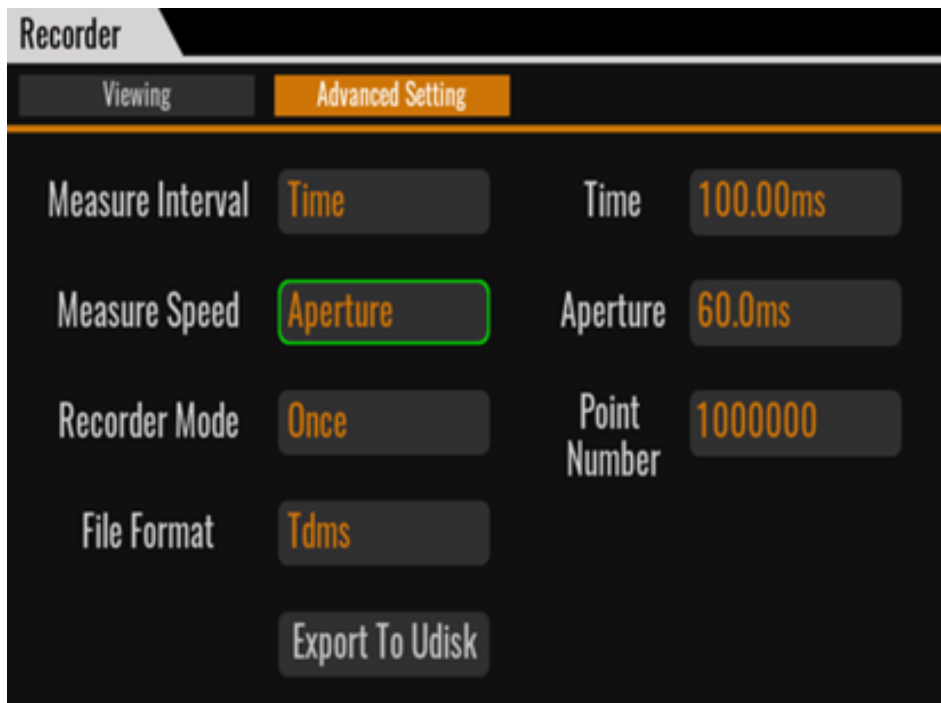
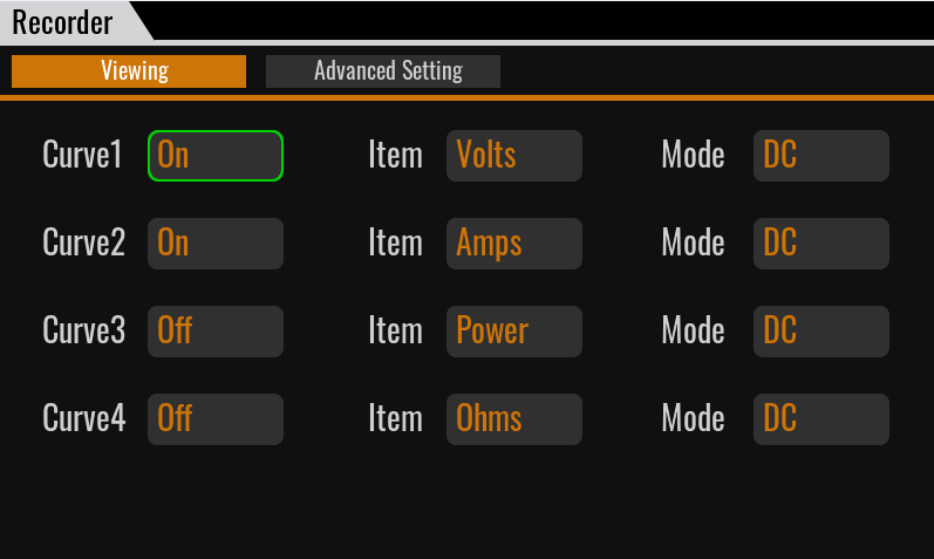

Parameter	Description
Curve 1/2/3/4	Select the curve type under Recorder function, support up to 4 curves simultaneously.
Item	The type of curve plotting/data logging.
Mode	Set the display mode of the curve, DC or AC can be selected. <ul style="list-style-type: none"> <li>DC mode: The curve scale is displayed centered on 0.</li> </ul>

Parameter	Description
	<ul style="list-style-type: none"> <li>AC mode: The curve scale takes the lowest value of a waveform as the scale Base value. The corresponding value of the display scale is Base + Div.</li> </ul>
Measure Interval	<p>Set the measurement interval, i.e. the setting of the sampling rate.</p> <ul style="list-style-type: none"> <li>NPLC: When <b>NPLC</b> option is selected, the screen pops up with PLC parameter setting, unit: PLC.                             <ul style="list-style-type: none"> <li>50Hz: 0.005PLC-100.00PLC</li> <li>60Hz: 0.006PLC-120.00PLC</li> </ul> </li> <li>Time: When <b>Time</b> option is selected, the screen pops up the Speed setting, the setting range: 100us~2s.</li> </ul> <p><b>Note: This parameter cannot be set after the Recorder is running.</b></p>
Measure Speed	<p>Set the speed of the measured data, i.e. the duration of a single measurement.</p> <ul style="list-style-type: none"> <li>NPLC: When <b>NPLC</b> option is selected, the screen pops up with PLC parameter setting, setting range: 0.0005~6.4, unit: PLC.</li> <li>Aperture: When <b>Aperture</b> option is selected, the screen pops up with Speed setting, the setting range: 0.00001s – Max s.</li> </ul> <p><b>Max = Measure Interval *80% ; Measure Interval - Measure Speed &gt; 40us</b></p> <p><b>Note: This parameter cannot be set after the Recorder is running.</b></p>
Recorder Mode	<p>Set the mode of data recording, you can choose Cycle or Once.</p> <p>When Cycle is selected, the Point Number setting item is hidden. By default, the maximum number of sampling points is 1,000,000. After the maximum number of</p>

Parameter	Description
	sampling points is reached, it will be cyclically covered. When selecting Once, you can set the Point Number item. <b>Note: This parameter cannot be set after the Recorder is running.</b>
Point Number	Set the depth of data logging, that is, the number of collected data points. When the Recorder starts running and the collection quantity reaches the set number, it will automatically stop recording. Setting range: 1~1000000. <b>Note: This parameter cannot be set after the Recorder is running.</b>
File Format	The formats of the files exported to the USB drive: Tdms or csv formats.
Export To Udisk	Select whether to export the acquired data to a USB flash drive.
Save To Udisk Real-time	Select whether to export to a USB flash drive in real time. <ul style="list-style-type: none"> <li>• Off: This function is turned off.</li> <li>• On: This function is turned on.</li> </ul> After the Recorder function Run, there is no limit to the amount of data acquired when saving the real-time acquired data to a USB flash drive, but it is recommended to set the acquisition speed <b>Manual S</b> is 1ms or more.

- Hold-On / Hold-Off: Pause / Resume data recording or curve plotting.
  - Auto: Self-adaptive function. The screen will automatically adjust the drawing height according to the actual measurement data.
4. Setting of X-axis (time) and Y-axis (voltage, current) resolution
- a. Touch the corresponding area with your finger to enter the pending edit state, as shown in the following figure.

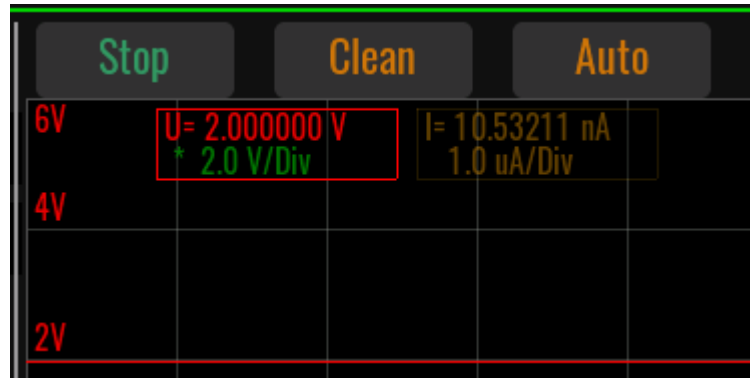

- b. Turn the knob or press the left / right key to adjust.
5. After clicking **Run**, the voltage curve and current curve are drawn during the data recording process.

The color of the curve drawn in the Recorder is only related to the selection of the curve, and has nothing to do with the selected data type.

## 1.6.4 Sweep

Sweep mode supports scanning output of multiple waveforms, as shown in the figure below. Not only does it perform sweep output, but it also performs measurements for each step.

- Linear and logarithmic sweep

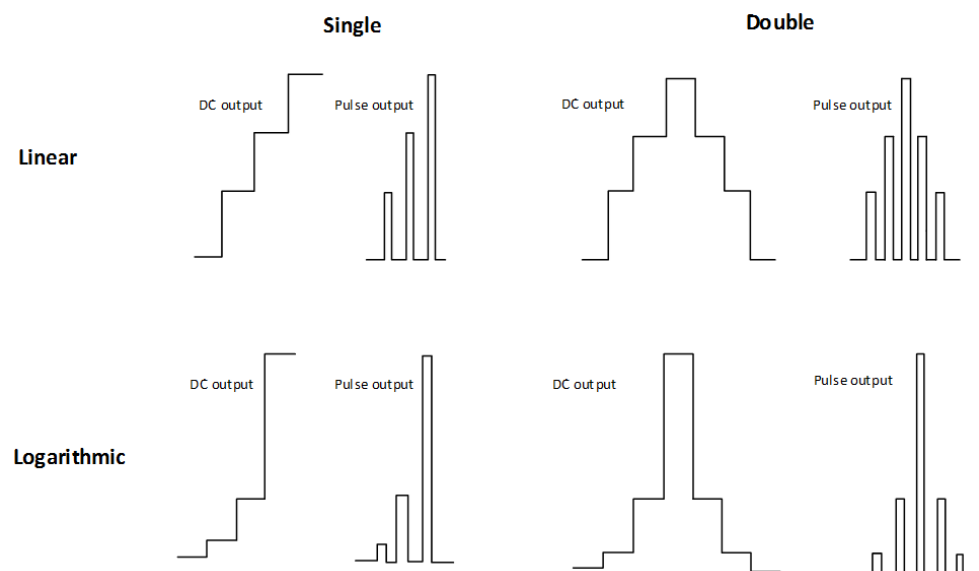

- User-defined (List)

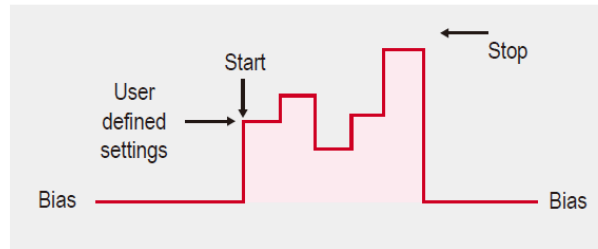

To access the Sweep interface:

Press the **[Menu]** key, enter **Menu**→**Sweep**.



- Run / Stop: Runs or stops Sweep. After running Sweep, a status marker will appear at the top of the screen that Sweep is started and waiting to be triggered to run. Also, **[On/Off]** must be turned on before Sweep can be started.

#### CAUTION

**Sweep and Recorder are not supported to be started at the same time, for example, if Recorder is already running, Sweep cannot be started.**

- U-I / I-U / Data List: Display of measurement data types during Sweep function operation.
  - U-I: Current-voltage curve, with the Y-axis representing voltage and the X-axis representing current.
  - I-U: Voltage-current curve (voltammetric characteristic curve), with the Y-axis indicating current and the X-axis indicating voltage.
  - Data List: The list of measurement data.

- Auto: Automatically adjusts the scale of the curve display on the X and Y axes so that the user can see the complete curve.
- Clear: Clear the history curve, the curve being drawn will not be cleared.
- Setting: Enter Sweep waveform parameter setting mode.

If Sweep is running at this time, all settings in the Setting screen will be grayed out and parameter settings cannot be modified.

- 0.000V / 0.000A: Starting value for X and Y coordinate axes (voltage and current)
- 10.000V / 1.000A: Ending value for X and Y coordinate axes (voltage and current)



#### Note

The end value must be greater than the start value.



- : Sweep / List running status display. The progress bar and percentage at the top of the screen indicate the total number of steps in Sweep / List and how many steps have been run. The Step below indicates the set value of a single step.

## How to Use

1. Press the **Setting** key to enter the parameter setting interface in Sweep mode.
2. Set **Common Setting**→**Mode**, different options correspond to different waveform parameters.
3. Select **Trigger Setting**→**Start Trigger Source** to set the triggering method.
4. After the parameters are set, turn on the **[On/Off]**.
5. Press **[Run]** from the Sweep main screen.
6. Triggers Sweep to run according to the triggering source that has been set.

## 1.6.5 Meas ohms

IT2800 supports resistance measurement. When the resistance measurement function is turned on, the source/measure unit (SMU) automatically sets the current source and voltage measurement operation to perform resistance measurement.

To access the Meas ohms interface:

Press the **[Menu]** key, enter the **Menu→Meas ohms**.

Parameter	Description
Ohms	<ul style="list-style-type: none"> <li>On: Resistance measurement function is turned on</li> </ul>  <b>Note</b> At this time, the <b>I Set, I Range, V Limit, V Range</b> parameters cannot be modified. <ul style="list-style-type: none"> <li>Off: Resistance measurement function is turned off</li> </ul>
Range	Selecting the range for resistance measurement
R Compen	Resistance compensation (R Compen) is effective for performing low resistance measurements accurately. If R Compen is set to ON, the channel performs measurement twice and returns the compensated measurement result given by the following formula. This technique is effective for reducing the thermal EMF. $R_{\text{compen}} = (V_2 - V_1) / (I_2 - I_1)$ $V_1$ is the measurement results at the 0 A source condition, and $I_1$ is the measurement results at the 0 V source condition.

## 1.6.6 Meas limit

Limit test is a pass/fail judgement performed for a measurement data or math result data obtained by a SMU channel. Maximum of twelve limit tests can be defined and used for the bins of composite limit test.

Composite limit test supports the following two operation modes.

- Grading mode

Performs limit test for up to 12 test limits (bins) until a failure is detected. See the figure below for an example flowchart.

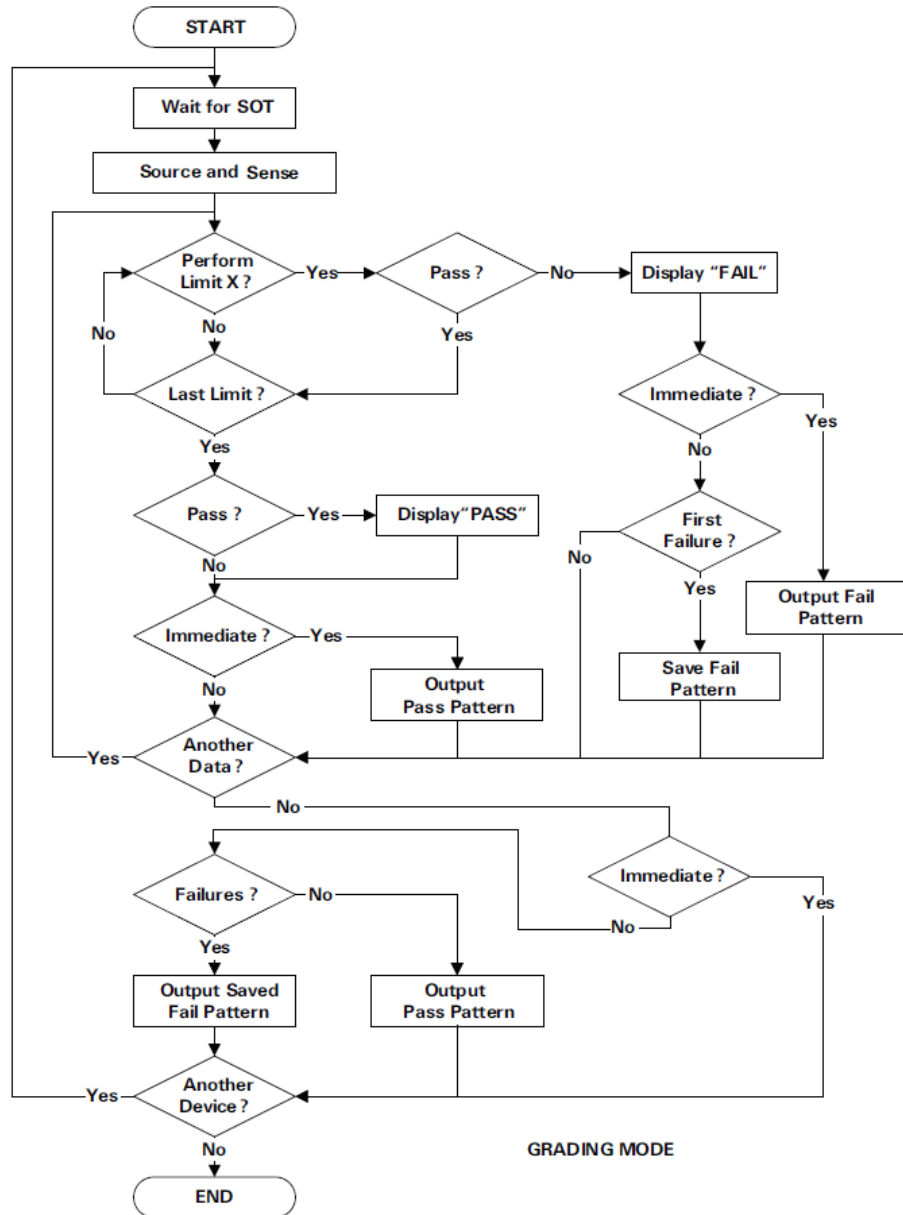

- Sorting mode

Performs limit test for up to 12 test limits (bins) until a pass is detected. See the figure below for an example flowchart.

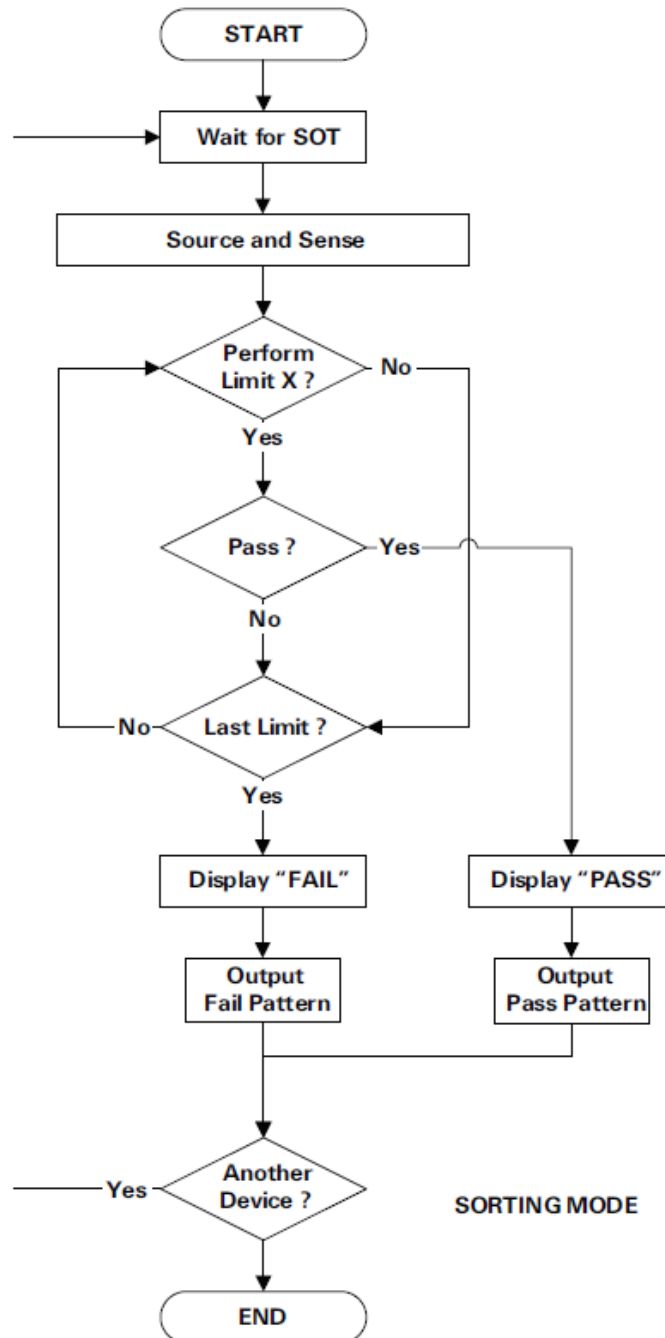

The individual pins used by Digital IO in the limit test function are defined as follows.

- Pattern bit: pin1-pin12
- SOT (Start Of Test): pin13
- Busy: pin14
- EOT (End Of Test): pin15

The diagram of each state is shown below.

### Digital output auto-clear timing example

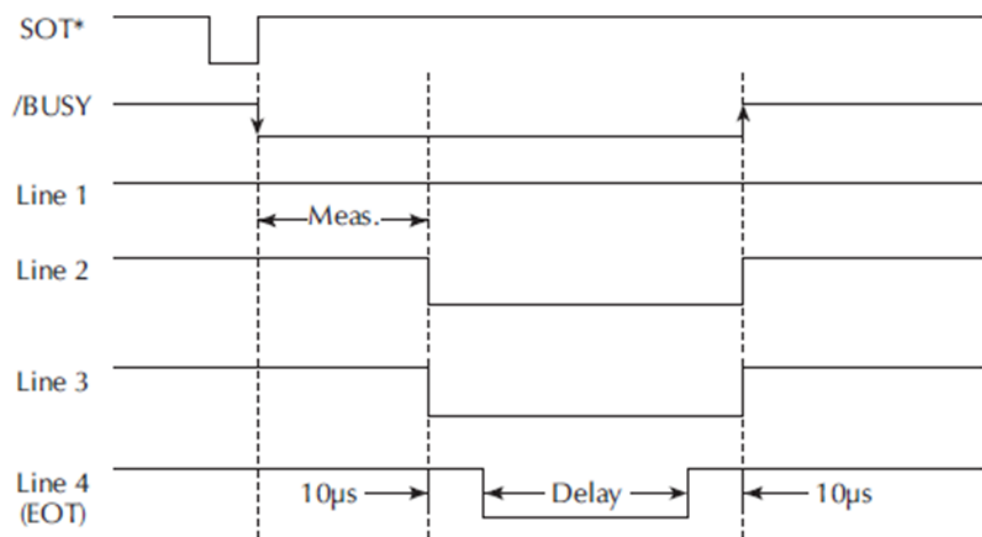

The **Setting** interface parameters are described as follows.

Tab	Parameter	Description
Common Setting	Mode	The mode of limit testing. <ul style="list-style-type: none"> <li>• Grading</li> <li>• Sorting</li> </ul>
	Feed Data	The type of data used for the pass/fail judgment of the limit test. <ul style="list-style-type: none"> <li>• Volts: Voltage measurement data</li> <li>• Amps: Current measurement data</li> <li>• Ohms: The resistance data specified by <math>R = V_{meas}/I_{meas}</math>. If the resistance compensation function is turned on, the compensated resistance value is used.</li> <li>• Math: Calculated result data for mathematical expressions</li> </ul>
	Limits	Set the number of limit tests, the setting range is 1~12. For example, if 12 times is selected, each value is tested up to 12 times.
	Components	The number of test data. Setting range: 0~50000. When the setting value is 0, it means infinite test until <b>Stop</b> key is pressed.

Tab	Parameter	Description
	Update	This parameter setting is only available in Grading mode. <ul style="list-style-type: none"> <li>• Immediate: Output the result immediately when test fail and stop this test; output the result immediately when test pass and stop this test.</li> <li>• End: When testing fail, if it is the first fail, save the fail pattern and retest. If it is not the first time to fail, directly retest until the number of times specified by <b>Repeat Counts</b> is finished. After multiple tests, if all pass, output the result as pass, otherwise output the first fail pattern.</li> </ul>
	Repeat Counts	This parameter is set only when <b>Update</b> is set to <b>End</b> . Indicates the number of times to repeat the test if the test fails under the same test. Setting range: 2~1000.
	All Pass / Fail Pattern	Setting range: 0~4095. In Grading mode, all tests pass the output pattern. This pattern will be output to digital IO, pin1-pin12. Output according to 000000000000b. Pin12 is the highest bit. In Sorting mode, all test fail output pattern. This pattern will be output to pin1-pin12 of digital IO. Default: 0xff
	Start of Test	The signal source to start the test. <ul style="list-style-type: none"> <li>• Digital IO: Triggered by IO pin13</li> <li>• Manual: Triggered by the front panel <b>[Trig]</b> key</li> <li>• Bus: Triggered by command</li> </ul>
	Auto Clear	Automatic clearing of test results. <ul style="list-style-type: none"> <li>• On: Automatically clear the test result (pass or fail status, IO Pattern level) with a delay time of EOT Delay.</li> <li>• Off: Keeps the test results displayed until the next <b>Start of Test</b> signal arrives.</li> </ul>

Tab	Parameter	Description
	EOT Delay	Used to indicate the delay time for outputting Digital signal after the test is finished. The EOT signal is output to pin15 of Digital IO. Setting range: 30us~60s (adjustment step is 10us)
Limit Setting ( Grading Mode )	Limit X	Not editable. Corresponds to the number settings of <b>Common Setting</b> → <b>Limits</b> . How many quantities are set in <b>Limits</b> , the corresponding numbers will be displayed here.
	Limit 1	<ul style="list-style-type: none"> <li>• Compliance: compliance check. Compare with Limit under Config.  Select this mode and set the following parameters.  Fail On: Applicable to compliance check only. OUT or IN can be selected. <b>In</b> means the measured value is within the limit; <b>Out</b> means the measured value exceeds the limit. Fail on=IN determines that the limit test has failed if the channel goes into compliance, and Fail on=OUT determines that it has succeeded. If the channel is not in compliance, Fail on=OUT will determine that the limit test failed.  Fail Pattern: Bit pattern for the limit test fail state. Setting range: 0~4095.</li> <li>• Limit: Composite limit test  Select this mode and set the following parameters.  High Limit: Limit test upper limit  Low Limit: Limit test lower limit  Fail Pattern: Bit pattern for the limit test fail state. Setting range: 0~4095.</li> </ul> <p> <b>Note</b> Only Limit 1 can select Limit / Compliance mode, all others default to Limit.</p>

Tab	Parameter	Description
Limit Setting ( Sorting Mode )	Start Value	The starting value of the limit test
	LimitX Value	Indicates the limit test value. Corresponds to the number settings of <b>Common Setting</b> → <b>Limits</b> . How many quantities are set in <b>Limits</b> , the corresponding numbers will be displayed here.
	Pass Pattern	Bit pattern for the limit test pass state. Setting range: 0~4095.
Data Save	Export Data	Export the test data to a USB flash drive.
	Save to Udisk Real-time	Set to On to indicate that the test data is automatically saved to the USB flash drive in real time after Run.
Setting Save	Recall / Save / Delete	Used to recall/save/delete the configured <b>Meas Limit</b> function parameters. Saves all configured parameters under <b>Common Setting</b> and <b>Limit Setting</b> .

## 1.6.7 Meas math

The SMU provides a math function for performing calculations using the measurement result data. The calculation result can be displayed and used for the limit test and trace statistics. The predefined math expressions are not cleared by the power off and on operations.

To access the Meas math interface:

Press the [**Menu**] key, enter **Menu**→**Meas math**.

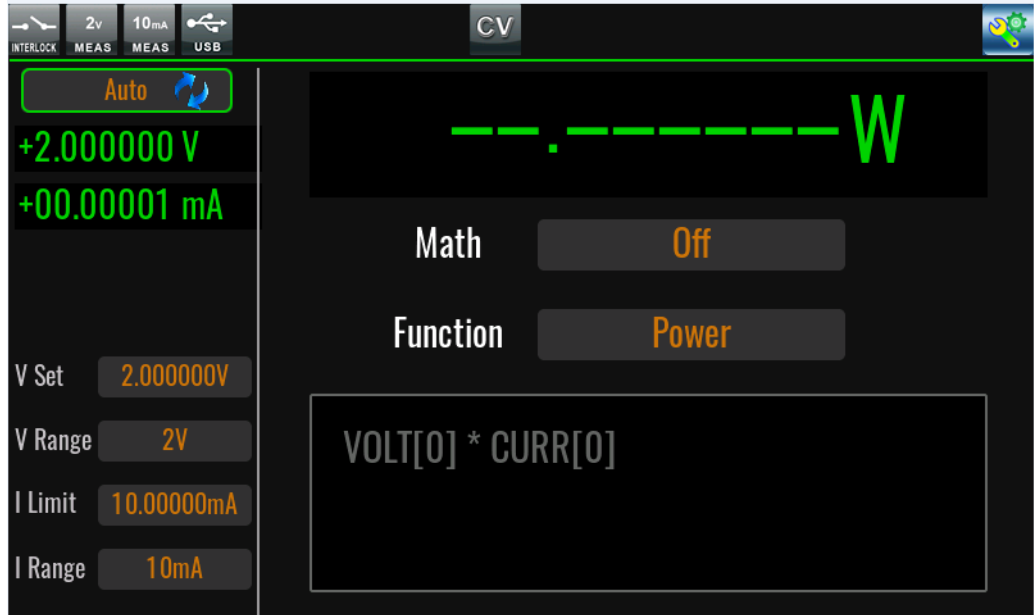

Parameter	Description
Math	<ul style="list-style-type: none"> <li>On: Turn on the math expression calculation function</li> </ul>  <b>Note</b> When this function is turned on, the instrument first calculates the voltage and current values in the Meter through expressions and then fills the calculated data results into the cache module. <ul style="list-style-type: none"> <li>Off: Turn off the math expression calculation function</li> </ul>
Function	<ul style="list-style-type: none"> <li>Power: POWER                              Calculates power using the following formula.  <math display="block">\text{Power} = \text{Volt} * \text{Curr}</math> </li> <li>Off-Comp-Ohm: Offset Compensated Ohms                              Calculates offset compensated ohms (resistance) using the following formula.  <math display="block">\text{OFFCOMPOHM} = (\text{VOLT}[1] - \text{VOLT}[0]) / (\text{CURR}[1] - \text{CURR}[0])</math>                             where, VOLT[0] and CURR[0] are the data measured with a current output level, and VOLT[1] and CURR[1] are the data measured with a different current output level or zero output.                              This function is effective for reducing measurement errors in low resistance measurements.                         </li> <li>Alpha: Varistor Alpha                              Calculates varistor alpha using the following formula.  <math display="block">\text{VARALPHA} = \log(\text{CURR}[1] / \text{CURR}[0]) / \log(\text{VOLT}[1] / \text{VOLT}[0])</math>                             where, CURR[0] and VOLT[0] are the measurement data at a point on a varistor's non-linear I-V characteristics curve, and CURR[1] and VOLT[1] are the data at the another point.                         </li> <li>Volt-Coef: Voltage Coefficient                              Calculates voltage coefficient using the following formula.  <math display="block">\text{VOLTCOEF} = (\text{RES}[1] - \text{RES}[0]) / (\text{RES}[1] * (\text{VOLT}[1] - \text{VOLT}[0])) * 100 \%</math>                             where, RES[0] and RES[1] are the resistance measurement data at the first and second measurement points, respectively, and VOLT[0] and VOLT[1] are the voltage                         </li> </ul>

Parameter	Description
	<p>measurement data at the first and second measurement points, respectively.</p> <p>The voltage coefficient is known as the ratio of the fractional change for a resistor whose resistance varies with voltage.</p> <ul style="list-style-type: none"> <li>• User-Define: Custom formula mode. For detailed function introduction, see <a href="#">3.10 Meas math Function</a>.</li> </ul>

## 1.6.8 System

Press **[Menu]**→**System** to enter the system menu.

General	General Settings	
	PLC	The power line frequency must be set properly for the AC power at your site. Press the following function keys to set the frequency to 50 Hz or 60 Hz.
	Digits	<p>Displays the following softkeys for specifying the data display resolution.</p> <ul style="list-style-type: none"> <li>• 3.5: Sets 3½ digit resolution.</li> <li>• 4.5: Sets 4½ digit resolution.</li> <li>• 5.5: Sets 5½ digit resolution.</li> <li>• (Default) 6.5: Sets 6½ digit resolution.</li> </ul>
	Key Sound	<p>Set the key sound switch.</p> <ul style="list-style-type: none"> <li>• On (default): On</li> <li>• Off: Off</li> </ul>
	Protection Alarm	<p>The buzzer alarm function when the instrument fails and protection occurs.</p> <ul style="list-style-type: none"> <li>• On (default): On</li> <li>• Off: Off</li> </ul>
	Brightness	Set the screen brightness. The setting range is 1~10. Default value: 3.
	Factory Default Setting	Press <b>[Enter]</b> to confirm restoring the factory settings. This operation restores all parameters in the <b>Menu</b> to the factory values, but does not include the saved data in the non-volatile memory.
	Power-on State	<ul style="list-style-type: none"> <li>• Reset: Initialize some settings and power output status when powering up again.</li> <li>• Last: When powering up again, the instrument maintains the settings (including range and setting values) and power output status before powering down.</li> </ul>

		<ul style="list-style-type: none"> <li>• Last+Off: When re-powered, the instrument maintains the settings before power off, but the power output status is off.</li> </ul>
	Multichannel mode Role	Multi-channel function setting. <ul style="list-style-type: none"> <li>• Single (default): Single mode</li> <li>• Master: Master mode</li> <li>• Slave: Slave mode</li> </ul>
	Immediate update by knob State	Sets whether the knob adjustment takes effect immediately. <ul style="list-style-type: none"> <li>• On: This function is turned on.</li> <li>• Off (default): This function is off.</li> </ul>
	Language	Interface language settings allow for the selection of English or Chinese interface.
Communication	Set the communication parameters between the instrument and the computer (e.g. insert the optional communication board to automatically display the corresponding interface information)	
	USB Type	Set the USB port type. <ul style="list-style-type: none"> <li>• Device (default): Select this item, the rear panel USB-B interface of the instrument is used to connect to the computer for communication. The USB-A interface on the front panel of the instrument is not available, even if the U disk is inserted, it cannot be recognized at this time.</li> <li>• Host: Select this item, the USB-A interface on the front panel of the instrument is used to connect to the U disk to store data or take screenshots, and the USB-B interface on the back panel of the instrument cannot be used as the communication interface at this time. And, the <b>USB Device</b> cannot be set.</li> </ul>
	USB Device	Used to set the communication method of the USB-B interface on the rear panel of the instrument. Valid only when <b>USB Type</b> is set to <b>Device</b> . <ul style="list-style-type: none"> <li>• VCP (default): Virtual serial communication method. When the computer is Win 7 version operating system, you need to install the corresponding virtual serial driver, please download it from ITECH official website or contact ITECH support to get it, Win 10 and above professional version systems do not need to install the driver.</li> <li>• TMC: TMC communication method. You need to download the VISA driver from the NI official website to match the computer OS version.</li> </ul>
	LAN Config	Set the network port communication parameters. <ul style="list-style-type: none"> <li>• Mode: Set LAN communication mode Manual or DHCP. If select Manual, you need to set IP, Mask and Gateway manually. If select DHCP, then IP, Mask and Gateway cannot be set.</li> <li>• IP: Set IP address Default: 192.168.200.100</li> <li>• Mask: Set the subnet mask</li> </ul>

		<ul style="list-style-type: none"> <li>Gateway: Set the gateway address</li> <li>Port: Set the port number, the setting range is 10000-60000. Default value is 30000.</li> </ul>										
	GPIB config	GPIB communication interface configuration (only displayed when the IT-E176 interface card is inserted). Addr: Set GPIB address. Setting range: 1~30. Default: 25.										
I/O												
	Digital IO-1: Trigger1 ... Digital IO-8: Trigger8	IO pins 1~8 with Trigger signal. Each pin has the same function definition, and the following is an example of one pin.										
		<table border="1"> <tr> <td>Reverse</td> <td>Whether to toggle the pin input/output level between high and low signals.</td> </tr> <tr> <td>Off</td> <td>                             Not converted.                             <ul style="list-style-type: none"> <li>Trig-out: The pin outputs a low level/pulse signal after receiving a trigger signal from a <b>[Trig]</b> key or command.</li> <li>Trig-in: Generate a trigger when the pin receives a 0V low level/pulse signal.</li> <li>Output: When <b>Set</b> is set to <b>Off</b>, the pin outputs 5V high level; when <b>Set</b> is set to <b>On</b>, the pin outputs a 0V low level.</li> <li>Input: Pin is used to receive level/pulse signal, when the pin receives 5V high level, <b>Status</b> is displayed as <b>Off</b>; when the pin receives 0V low level, <b>Status</b> is displayed as <b>On</b>.</li> </ul> </td> </tr> <tr> <td>On</td> <td>                             Converted                             <ul style="list-style-type: none"> <li>Trig-out: The pin outputs a high level/pulse signal after receiving a trigger signal from a <b>[Trig]</b> key or command.</li> <li>Trig-in: Generate a trigger when the pin receives a 5V high level/pulse signal.</li> <li>Output: When <b>Set</b> is set to <b>Off</b>, the pin outputs 0V low level; when <b>Set</b> is set to <b>On</b>, the pin outputs 5V high level.</li> <li>Input: Pin is used to receive level/pulse signal, when the pin receives 0V low level, <b>Status</b> is displayed as <b>Off</b>; when the pin receives 5V high level, <b>Status</b> is displayed as <b>On</b>.</li> </ul> </td> </tr> <tr> <td>Function</td> <td>Specifies the function of the pin.</td> </tr> <tr> <td>Trig-in</td> <td>(Default) The pin is used to receive the trigger signal. Valid only when the</td> </tr> </table>	Reverse	Whether to toggle the pin input/output level between high and low signals.	Off	Not converted. <ul style="list-style-type: none"> <li>Trig-out: The pin outputs a low level/pulse signal after receiving a trigger signal from a <b>[Trig]</b> key or command.</li> <li>Trig-in: Generate a trigger when the pin receives a 0V low level/pulse signal.</li> <li>Output: When <b>Set</b> is set to <b>Off</b>, the pin outputs 5V high level; when <b>Set</b> is set to <b>On</b>, the pin outputs a 0V low level.</li> <li>Input: Pin is used to receive level/pulse signal, when the pin receives 5V high level, <b>Status</b> is displayed as <b>Off</b>; when the pin receives 0V low level, <b>Status</b> is displayed as <b>On</b>.</li> </ul>	On	Converted <ul style="list-style-type: none"> <li>Trig-out: The pin outputs a high level/pulse signal after receiving a trigger signal from a <b>[Trig]</b> key or command.</li> <li>Trig-in: Generate a trigger when the pin receives a 5V high level/pulse signal.</li> <li>Output: When <b>Set</b> is set to <b>Off</b>, the pin outputs 0V low level; when <b>Set</b> is set to <b>On</b>, the pin outputs 5V high level.</li> <li>Input: Pin is used to receive level/pulse signal, when the pin receives 0V low level, <b>Status</b> is displayed as <b>Off</b>; when the pin receives 5V high level, <b>Status</b> is displayed as <b>On</b>.</li> </ul>	Function	Specifies the function of the pin.	Trig-in	(Default) The pin is used to receive the trigger signal. Valid only when the
Reverse	Whether to toggle the pin input/output level between high and low signals.											
Off	Not converted. <ul style="list-style-type: none"> <li>Trig-out: The pin outputs a low level/pulse signal after receiving a trigger signal from a <b>[Trig]</b> key or command.</li> <li>Trig-in: Generate a trigger when the pin receives a 0V low level/pulse signal.</li> <li>Output: When <b>Set</b> is set to <b>Off</b>, the pin outputs 5V high level; when <b>Set</b> is set to <b>On</b>, the pin outputs a 0V low level.</li> <li>Input: Pin is used to receive level/pulse signal, when the pin receives 5V high level, <b>Status</b> is displayed as <b>Off</b>; when the pin receives 0V low level, <b>Status</b> is displayed as <b>On</b>.</li> </ul>											
On	Converted <ul style="list-style-type: none"> <li>Trig-out: The pin outputs a high level/pulse signal after receiving a trigger signal from a <b>[Trig]</b> key or command.</li> <li>Trig-in: Generate a trigger when the pin receives a 5V high level/pulse signal.</li> <li>Output: When <b>Set</b> is set to <b>Off</b>, the pin outputs 0V low level; when <b>Set</b> is set to <b>On</b>, the pin outputs 5V high level.</li> <li>Input: Pin is used to receive level/pulse signal, when the pin receives 0V low level, <b>Status</b> is displayed as <b>Off</b>; when the pin receives 5V high level, <b>Status</b> is displayed as <b>On</b>.</li> </ul>											
Function	Specifies the function of the pin.											
Trig-in	(Default) The pin is used to receive the trigger signal. Valid only when the											

				<b>Config</b> → <b>Advanced Setting</b> → <b>Trigger</b> → <b>Source</b> is set as <b>Trigger</b> .		
			Trig-out	The pin is used to output the trigger signal. Valid only when the <b>Config</b> → <b>Advanced Setting</b> → <b>Trigger</b> → <b>Source</b> is set to a trigger method other than <b>Trigger</b> . For example, if it is set to <b>Manual ([Trig] key trigger)</b> , the pin will output a pulse signal when the key is pressed once.		
				<table border="1"> <tr> <td>Pulse width</td> <td>Set the pulse width, range: 30us~10ms.</td> </tr> </table>	Pulse width	Set the pulse width, range: 30us~10ms.
Pulse width	Set the pulse width, range: 30us~10ms.					
			Input	Indicates the input level of the pin.		
			Output	Output level/pulse signal.		
				<table border="1"> <tr> <td>Set</td> <td>Set the pin to output 0V or 5V.</td> </tr> </table>	Set	Set the pin to output 0V or 5V.
Set	Set the pin to output 0V or 5V.					
	Digital IO-9 ... Digital IO-12 Digital IO-16	Digital IO pins without trigger function, the parameter function is the same as Pin1~Pin8 above.				
	Digital IO-13: /SOT	Start of Test (SOT) input (for component handlers) Only <b>Reverse</b> settings are supported, <b>Function</b> and <b>Set</b> cannot be specified.				
	Digital IO-14: /Busy	Busy status output (for component handlers) Only <b>Reverse</b> settings are supported, <b>Function</b> and <b>Set</b> cannot be specified.				
	Digital IO-15: /EOT	End of Test (EOT) output (for component handlers) Only <b>Reverse</b> settings are supported, <b>Function</b> and <b>Set</b> cannot be specified.				
Fiber	Fiber synchronous trigger function in multi-device mode. Trigger functions can be mapped to fiber optic pins. Settings are only supported in multi-device mode. <ul style="list-style-type: none"> <li>• Trigger1_in -&gt; fiber25</li> <li>• Trigger2_in -&gt; fiber26</li> <li>• Trigger3_in -&gt; fiber27</li> <li>• Trigger4_in -&gt; fiber28</li> <li>• ManualTrigger -&gt; fiber29</li> <li>• GpibTrigger -&gt; fiber30</li> <li>• BusTrigger -&gt; fiber31</li> <li>• ScopeTrigger -&gt; fiber32</li> </ul>					
Information	View system information					
	Product Model	Model of the instrument				

	SN	Serial number of the instrument
	Software Version	Software firmware version number
	MAC Address	MAC Address
	Ctrl1 Version	Control program 1 version
	Ctrl2 Version	Control program 2 version
	Disp Version	Display board program version

## 1.6.9 Config

Press **[Menu]**→**Config** to enter the configuration interface.

Source	Source parameter configuration		
	Pulse	Pulse output mode	
		State	Whether to turn on the pulse output.
		Priority	Sets the start level of the pulse. Supports selecting the voltage or current defined by Base, or selecting the voltage or current defined by Peak (i.e. <b>V Set</b> or <b>I Set</b> in Meter interface).
		Base	Set the Base level.
		Delay	Set the pulse delay time. After the delay time following the trigger delay, the pulse source changes the output level from the base value to the peak value. Range: 50us~1000s.
		Width	Set the pulse width. Range: 50us~1000s.
		General	Common output mode
		Mode	Selects the voltage source or current source output mode.
		HC Mode	<b>Only supported by models IT2805, IT2806, IT2805R, and IT2806R</b> <b>Voltage Source</b> output mode supports toggling <b>HC Mode</b> (high capacitance mode) on or off.
		Loop Speed	In <b>Current Source</b> output mode, it is possible to set the current loop speed to <b>Normal</b> or <b>High</b> .
		V Set / I Set	Set the output voltage or current value according to the selected voltage source or current source. In pulse mode, it represents V-Peak or I-Peak.
		V Range / I Range	Set the voltage range or current range according to the selected voltage source or current source.

	I Limit / V Limit	Set the current upper limit value or voltage upper limit value according to the selected voltage source or current source.
	I Range / V Range	Set the range of the upper limit current or the range of the upper limit voltage according to the selected voltage source or current source.
	Serial Resistance	Set the output resistance. Setting range: 0~100Ω. <b>Setting this parameter is only supported in voltage source mode.</b>
Output Filter	Output filter ON or OFF Set the filter ON to obtain clean source output without spikes and overshooting. Note, however, that using a filter may increase the SMU settling time. When set to On, the following parameters need to be set.	
	Auto Filter	Automatic filter ON or OFF Set the function ON to automatically set the output filter which provides the best filter characteristics and cutoff frequency. When set to Off, the following parameters need to be set.
	Time Constant	Filter time constant, 10us to 10ms
Output Slope Limit	Set the output slope; the following slope settings apply to both rising and falling slopes.	
	State	Set the slope control switch: <ul style="list-style-type: none"> <li>• On: Enabled</li> <li>• Off: Disabled</li> </ul>
	Auto Slope	Set automatic slope adjustment. <ul style="list-style-type: none"> <li>• On: Enabled</li> </ul> Use the default slope: 6V/us in voltage source mode; 1A/us in current source mode. <ul style="list-style-type: none"> <li>• Off: Disabled</li> </ul> When selected as Off, it is necessary to set <b>Slope Set</b> .  <b>In voltage source mode, it represents the control of the voltage slope; in current source mode, it represents the control of the current slope.</b>
Output Connection	Output Status Setting	
	Output-off State	The output is turned off with a choice of high impedance (High-Z) or zero volts (Zero). <ul style="list-style-type: none"> <li>• High-Z: High impedance</li> </ul> Output relay: off (open or break); Voltage source and current source setup is not changed. <ul style="list-style-type: none"> <li>• Zero: Quick zeroing.</li> </ul>

			Output relay: on (closed); Output voltage: 0 V; The measuring range remains the same.
		Over V/I Protect	Over-voltage or over-current protection. Turn off the output when the channel output reaches the compliance limit (Limit).
		Auto Output-on	If this function is enabled, the source/measure unit (SMU) automatically turns the channel output ON just before the trigger system is initiated by an SCPI command, not by a front panel operation.
		Auto Output-off	If this function is enabled, the SMU automatically turns the channel output OFF immediately when all trigger system changes the status from busy to idle.
Measure	Measurement parameter configuration		
	General	Common output mode	
		View Type	Measurement type selection, the following types are supported. Volts&Amps/Volts&Ohms/Volts&Watts/Amps&Volts/Amps&Ohms/Amps&Watts/Ohms&Volts/Ohms&Amps/Ohms&Watts/Watts&Volts/Watts&Amps/Watts&Ohms If you select Volts&Amps, the first line of the Meter interface shows the voltage and the second line shows the current.
		Sensing Type	Whether to turn on the Sense function. Select 2-wire connection (Sense off) or 4-wire connection (Sense on).
		Measure Unit	Set the measurement unit, i.e. the measurement speed.
		Aperture / NPLC	<ul style="list-style-type: none"> <li>Aperture: Take time as the unit, set the measurement speed, range: 10us~2s.</li> <li>NPLC: In PLC (power line cycles, number of power line cycles per measurement). The setting range is as follows.                             <ul style="list-style-type: none"> <li>50Hz: 0.0005~100PLC</li> <li>60Hz: 0.0006~120PLC</li> </ul> </li> </ul>
	Auto Range Low-limit	The minimum limit of Auto range for voltage or current.	
		Volts	Sets the minimum limit for the voltage Auto range.
		Amps	Sets the minimum limit for the current Auto range.
Advanced Setting	Other settings		
	Wait Control Source	This function provides the following parameters for setting the source wait time. The source wait time is defined as the time the source channel cannot change the output after the start of a DC output or the trailing edge of a pulse. If set to On, the following parameters need to be set. If set to Off, the wait time = 0.	
		Automatic	Automatic wait time ON or OFF

			<ul style="list-style-type: none"> <li>If set to On, the Gain parameter needs to be set. See the following formula.  <math display="block">\text{wait time} = \text{Gain} \times \text{initial wait time} + \text{Offset}</math>                     The initial wait time is automatically set by the instrument, and cannot be changed.</li> <li>If set to Off, see the following formula.  <math display="block">\text{wait time} = \text{Offset}</math></li> </ul>
		Gain	Gain coefficient, range: 0~100.
		Offset	Offset value, range: 0~1s.
	Wait Control Measure	This function provides the following parameters for setting the measurement wait time. The measurement wait time is defined as the time the measurement channel cannot start measurement after the start of a DC output or the trailing edge of a pulse. If set to On, the following parameters need to be set. If set to Off, the wait time = 0.	
		Automatic	Automatic wait time ON or OFF <ul style="list-style-type: none"> <li>If set to On, the Gain parameter needs to be set. See the following formula.  <math display="block">\text{wait time} = \text{Gain} \times \text{initial wait time} + \text{Offset}</math>                     The initial wait time is automatically set by the instrument, and cannot be changed.</li> <li>If set to Off, see the following formula.  <math display="block">\text{wait time} = \text{Offset}</math></li> </ul>
		Gain	Gain coefficient, range: 0~100.
		Offset	Offset value, range: 0~1s.
	Trigger	Setting the trigger source	
		Source	<ul style="list-style-type: none"> <li>Auto: Trigger source best suited for the present operating mode is automatically selected by the internal algorithms.</li> <li>Manual: Triggered by the <b>[Trig]</b> key.</li> <li>Bus: Triggered by a command, such as <b>*TRG</b>.</li> <li>Trigger: Triggered by Digital IO1~IO8 pins.</li> <li>Fiber: Triggered by Fiber 1~32.</li> </ul> Fiber optic trigger requires optional fiber optic module and fiber optic cable. Except the Auto option, the other trigger methods support setting the Delay time, range: 0~10000s.
	Trigger Output	Set the output mode of the trigger signal. <ul style="list-style-type: none"> <li>Off: No output</li> <li>Trigger: Trigger output by Digital IO1~IO8 pins.</li> </ul>	

		<ul style="list-style-type: none"> <li>Fiber: Trigger output by Fiber 1~32.</li> </ul>
	Source	Trigger output for source mode
	Sense	Trigger output for measurement mode
Limit 1 / Limit 2	To Set Individual Limit Tests Measurement results are displayed on the right side of the Home page (Pass/Fail)	
	State	On: Enable the function; Off: Disable the function.
	Feed Data	The type of data used for pass/fail judgments for individual limit tests, including: Volts/Amps/Ohms/Watts/Math. <ul style="list-style-type: none"> <li>MATH: Calculation result data of math expression</li> <li>VOLTS: Voltage measurement data (Vmeas)</li> <li>AMPS: Current measurement data (Imeas)</li> <li>OHMS: Resistance data (= Vmeas/Imeas)</li> <li>WATTS : Power data (= Vmeas*Imeas)</li> </ul>
	High Value	Upper limit for the pass/fail judgement. Above this value, it is Fail.
	Low Value	Lower limit for the pass/fail judgement. Below this value, it is Fail.
	Auto Clear	Whether or not to automatically clear the results of TestFail. On: When enabled, fail messages are automatically cleared. Off: After Fail alarm, it is not cleared automatically and must be cleared manually. Click <b>pass or fail clear</b> to clear it manually.
	Beep	Whether to generate a beep when Fail. When set to On, it means sound is generated when abnormal alarm is generated.

## 1.6.10 Battery

This series SMU supports battery simulation function, enter **Menu**→**Battery** interface. The introduction is as follows.

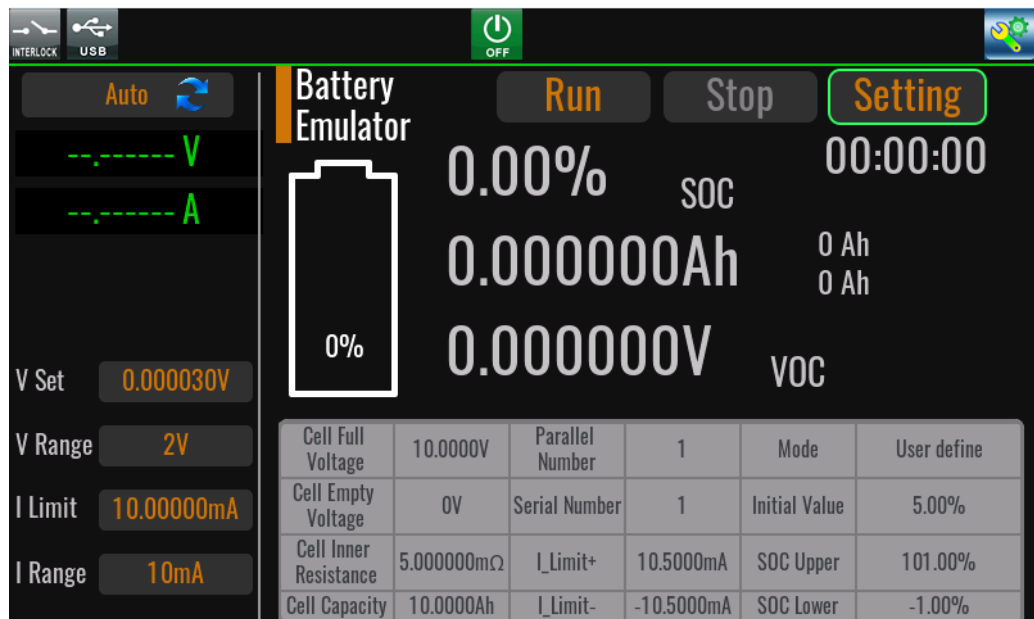

Click [**Setting**] to enter the battery simulation editing interface, and the parameters are described below.

Open File	Open a battery simulation file that has been saved in the instrument memory (Local) or saved on a USB flash drive (recall of USB flash drive files is only supported in Curve mode).
New File	<p>Create a new battery simulation file.</p> <p><b>User define</b> mode sets the following parameters.</p> <ul style="list-style-type: none"> <li>Cell Full Voltage: The full voltage of a cell</li> <li>Cell Empty Voltage: Empty voltage of a cell</li> <li>Cell Inner Resistance: The internal resistance of a cell</li> <li>Cell Capacity: The capacity of a cell</li> <li>Parallel Number: The number of parallel connections of cells</li> <li>Serial Number: The number of series connections of cells</li> <li>I_Limit+: The maximum discharge current of the battery as a whole</li> <li>I_Limit-: The maximum charge current of the battery as a whole</li> </ul> <p><b>Curve</b> mode sets the following parameters.</p> <ul style="list-style-type: none"> <li>Curve edit: Define <b>Cell SOC</b> (initial capacity of a cell), <b>Cell Voltage</b> (cell voltage), <b>Cell Res</b> (cell internal resistance value) for each <b>Point</b>, up to 10000 Points.</li> <li>Common edit: Define <b>Cell Capacity</b>, <b>Parallel Number</b>, <b>Serial Number</b>, <b>I_Limit+</b> (maximum discharge current of the</li> </ul>

	battery as a whole), <b>I_Limit</b> - (maximum charge current of the battery as a whole)
Save	Save the edited battery simulation file. Only displayed in User define mode.
Save As	Save the edited battery simulation file to the instrument memory (Local) or to a USB flash drive (Save to USB flash drive is supported in Curve mode only). This function supports editing the name of the saved file.
Delete File	Delete the battery simulation file from the instrument memory (- Local) or from the USB flash drive (deleting the USB flash drive file is only supported in Curve mode).
Mode	<ul style="list-style-type: none"> <li>• User define: User-defined mode</li> <li>• Curve: Curve mode</li> </ul>
Initial Value	Initial battery charge percentage (0%-100%)
SOC Upper	The upper limit (maximum value) of the charging capacity. Setting range: 100% - 110%, default:101%
SOC Lower	The lower limit (minimum value) of the discharge capacity. Setting range: 0%-(-10%), default:-1%
End Type	<ul style="list-style-type: none"> <li>• Hold: When charging to the upper capacity limit or discharging to the lower capacity limit, the capacity is held.</li> <li>• Off: When charging to the upper capacity limit or discharging to the lower capacity limit, the output is turned off.</li> </ul>

### Edit and run battery simulation files (User define)

1. Select **Mode** as **User define**.
2. Click **New File** to enter the battery simulation file editing interface.
3. Click on the screen to set parameters such as **Cell Full Voltage**.
4. Click **Save** to save the file.
5. Click **Open File** to select a file.
6. Press the **[Esc]** key to return to the main screen of the battery simulation.
7. Press the **[On/Off]** key to turn on the output.
8. Click **Run** to run the battery simulation.

During the running of battery simulation, you can click **Stop** to stop it.

## Edit and run battery simulation files (Curve)

1. Select **Mode** as **Curve**.
2. Click **New File** to enter the battery simulation file editing interface.
3. Click on the screen to set the **Curve edit** and **Common edit** parameters in the interface.

The setup method is as follows.

- a. Click on the screen to set a Point, as shown below.



No	Cell SOC	Cell Voltage	Cell Res
1...	50.00%	5.000V	100.000uΩ
2			

Buttons: Save, Save As, Clear All, Esc



### Note

After setting any of the parameters Cell SOC / Cell Voltage / Cell Res and pressing **[Enter]**, a record of Point (one line of data) is automatically generated.

- b. Set up multiple Points in the same way, up to 10,000.
  - c. Edit the parameters in **Common edit**.
  - d. Click **Save** to save the file.
  - e. Click **Esc** to exit the file editing.
4. Click **Open File** to select a file.
  5. Press the **[Esc]** key to return to the main screen of the battery simulation.
  6. Press the **[On/Off]** key to turn on the output.
  7. Click **Run** to run the battery simulation.

During the running of battery simulation, you can click **Stop** to stop it.

## 1.6.11 Save / Recall

This series of SMUs supports saving some commonly used Config configuration parameters in 10 groups (number: 1~10) of non-volatile memory, for users to take out conveniently and quickly. A total of 10 groups, each group can save 10 pieces of information, a total of 100 pieces of information can be saved.

The store/recall operation on the storage area can be implemented in the following way.

- Click **Menu**→**Save / Recall**
- SCPI commands: **\*SAV**, **\*RCL**.  
Command setting range: 1~100.
  - The first group: 1~10
  - The second group: 11~20
  - .....
  - Tenth Group: 91~100

### Save

1. Set the parameters in the SMU's **Menu**→**Config** menu to the desired values.
2. Click the screen **Menu**→**Save** to enter the parameter save screen, as shown below.

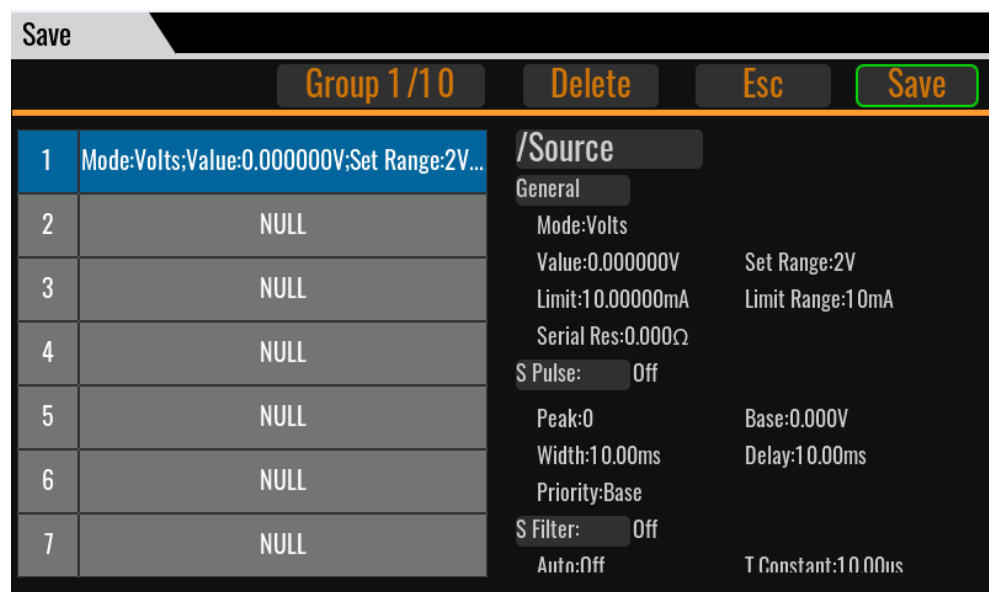

3. Click on the numbers 1~10 on the left side of the screen and select one of the addresses to save.

- Click **Save** at the top of the screen to confirm that the parameters are saved.

## Recall

- Click the screen **Menu**→**Recall** to enter the parameter recall screen, as shown below.

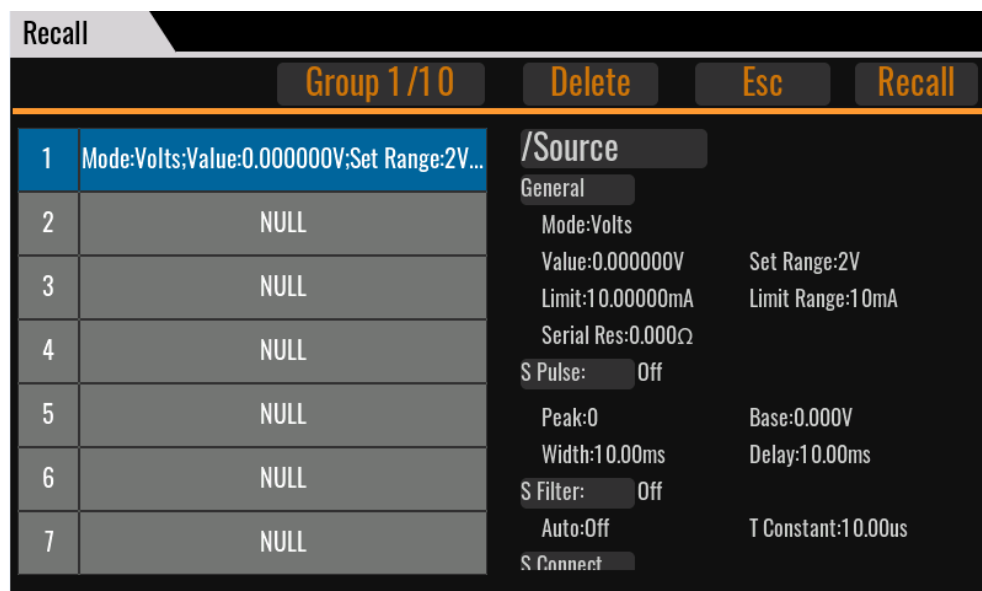

- Click on the numbers 1~10 on the left side of the screen to select one of the addresses where the existing data is saved.
- Click **Recall** at the top of the screen to confirm the parameter recall.

## 1.7 Models and Options

IT2800 Series Selection Table

Model	Voltage	Current	Power	Number of channels
IT2801 / IT2801R	1000V	1A	20W	One
IT2805 / IT2805R	200V	1.5A	20W	One
IT2806 / IT2806R	200V	3A DC / 10.5A Pulse	20W DC	One





**Note**





IT2801R, IT2805R, IT2806R are models with channel terminals on the front and rear panels.

**Optional Accessories**

Users can additionally purchase accessories to accompany this series of instruments, including the following categories and models.

- **Test Leads or Fixtures**

Model	Description	Image
IT-E801A	Banana to 4–Wire triaxial adapter. Suitable for IT2805, IT2805R, IT2806, IT2806R. See <a href="#">2.5 Connecting the Device Under Test (DUT)</a> for details.	
IT-E802A	Banana to 4–Wire triaxial adapter. Suitable for IT2801, IT2801R. See <a href="#">2.5 Connecting the Device Under Test (DUT)</a> for details.	
IT-E801B	Banana to 2–Wire triaxial adapter. Suitable for IT2805, IT2805R, IT2806, IT2806R. See <a href="#">2.5 Connecting the Device Under Test (DUT)</a> for details.	
IT-E801C-1.5	Low leakage triaxial cables. Length is 1.5m, suitable for IT2805, IT2805R, IT2806, IT2806R.	

Model	Description	Image
IT-E802C-1.5	Low leakage triaxial cables. Length is 1.5m, suitable for IT2801, IT2801R.	
IT-E803	Component testing fixture, with measurement specifications up to 40V, 1A. It comes standard with six test cables, which include: <ul style="list-style-type: none"> <li>• Four cables, each 50mm in length, with one end featuring a 1mm pin plug and the other end equipped with a miniature clip;</li> <li>• Two cables, each 50mm in length, with 1mm pin plugs at both ends.</li> </ul>	  
IT-E804	Test Fixture for Semiconductor Devices With measurement specifications up to 250V, 3A, and 10A Pulse. It comes standard with nine test cables, which include: <ul style="list-style-type: none"> <li>• One cable, 1500mm in length, featuring two DB25 connectors on one end and an aviation plug on the other;</li> </ul>	

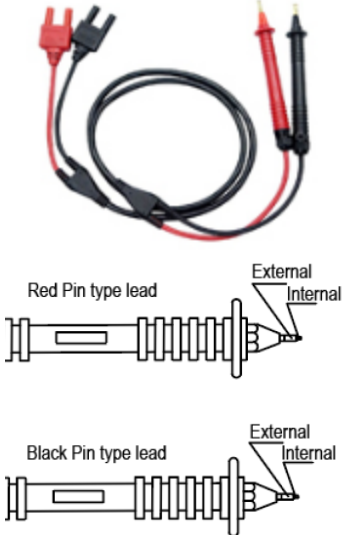
Model	Description	Image
	<ul style="list-style-type: none"> <li>Four cables, each 100mm in length, with one end featuring a 1mm pin plug and the other end equipped with a miniature clip;</li> <li>Four cables, each 100mm in length, with 1mm pin plugs at both ends.</li> </ul>	
IT-E601	Kelvin (4-wire) test cable. 300V banana to pin plug (- Crown Round Tip) connection cable (black), suitable for IT2805, IT2805R, IT2806, IT2806R.	

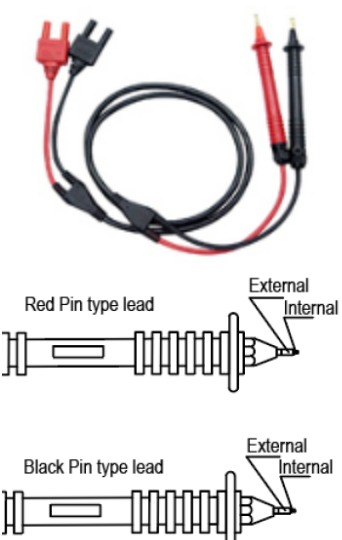
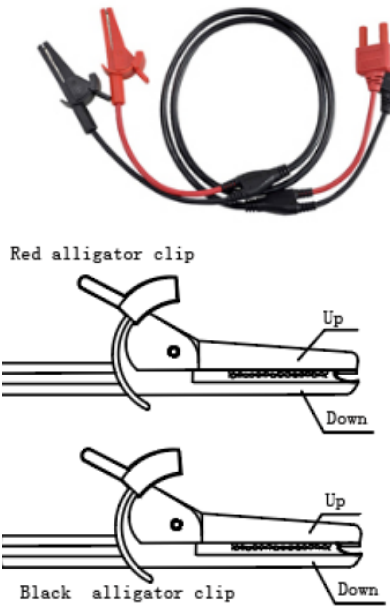
Model	Description	Image
IT-E601H	Kelvin (4-wire) test cable. 1000V banana to pin plug (- Crown Round Tip) connection cable (black), suitable for IT2801, IT2801R.	 <p>Red Pin type lead</p> <p>External Internal</p> <p>Black Pin type lead</p> <p>External Internal</p>
IT-E602	Kelvin (4-wire) test cable. 300V banana to alligator clip connection cable (black), suitable for IT2805, IT2805R, IT2806, IT2806R.	 <p>Red alligator clip</p> <p>Up Down</p> <p>Black alligator clip</p> <p>Up Down</p>

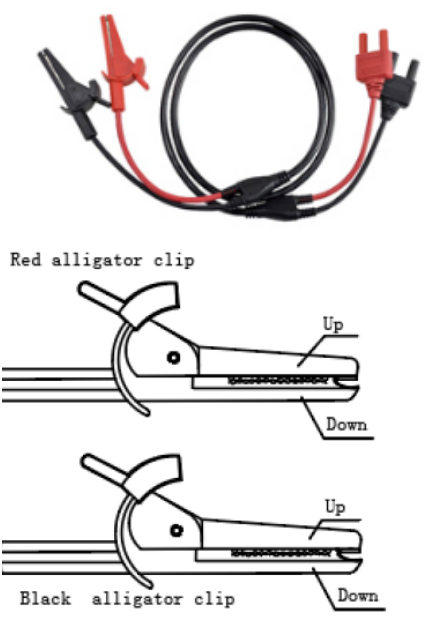
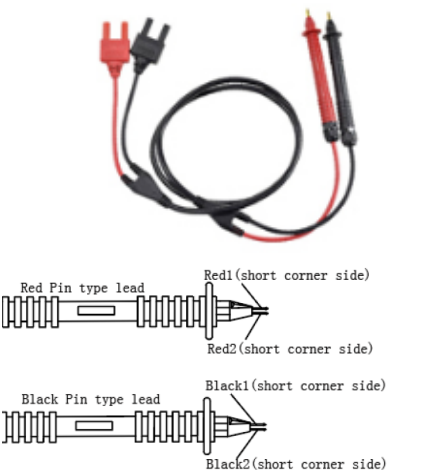
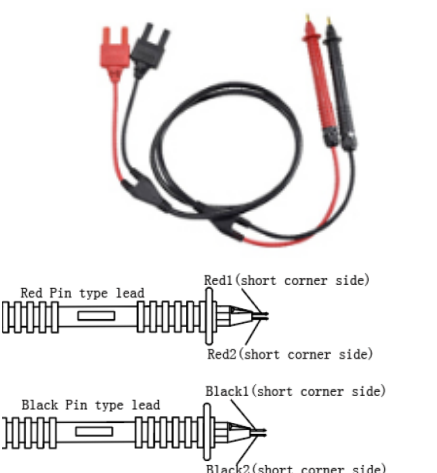
Model	Description	Image
IT-E602H	Kelvin (4-wire) test cable. 1000V banana to alligator clip connection cable (- black), suitable for IT2801, IT2801R.	 <p>Red alligator clip</p> <p>Up</p> <p>Down</p> <p>Black alligator clip</p> <p>Up</p> <p>Down</p>
IT-E603	Kelvin (4-wire) test cable. 300V banana to pin plug (- Cone Tip) connection cable (black), suitable for IT2805, IT2805R, IT2806, IT2806R.	 <p>Red Pin type lead</p> <p>Red1 (short corner side)</p> <p>Red2 (short corner side)</p> <p>Black Pin type lead</p> <p>Black1 (short corner side)</p> <p>Black2 (short corner side)</p>
IT-E603H	Kelvin (4-wire) test cable. 1000V banana to pin plug (- Cone Tip) connection cable (black), suitable for IT2801, IT2801R.	 <p>Red Pin type lead</p> <p>Red1 (short corner side)</p> <p>Red2 (short corner side)</p> <p>Black Pin type lead</p> <p>Black1 (short corner side)</p> <p>Black2 (short corner side)</p>

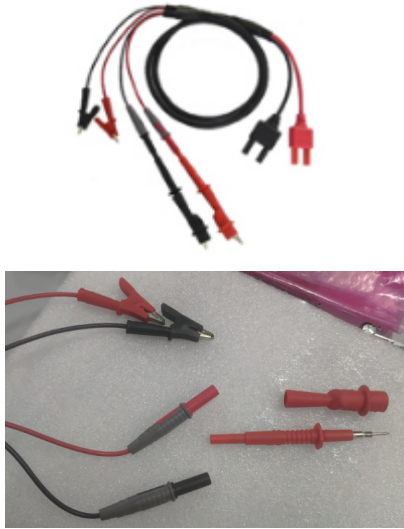
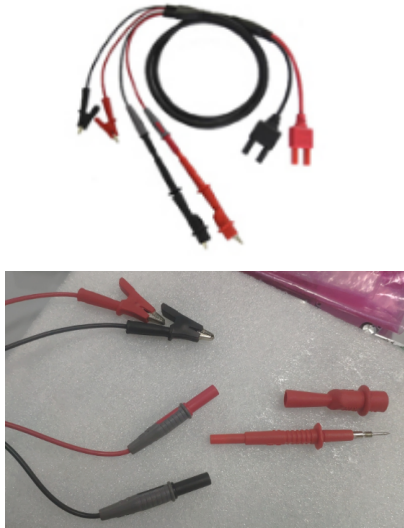
Model	Description	Image
IT-E604	Kelvin (4-wire) test cable. 300V banana to universal pin and alligator clip connection cable (black), suitable for IT2805, IT2805R, IT2806, IT2806R.	
IT-E604H	Kelvin (4-wire) test cable. 1000V banana to universal pin and alligator clip connection cable (black), suitable for IT2801, IT2801R.	

- **Extended Interface**

The IT2801, IT2805, IT2806 rear panel provides interface expansion slots for flexible expansion according to the user's needs, which can be inserted into the IT-E176 GPIB communication interface board.

**WARNING**

**It is strictly forbidden to directly insert and remove the communication card when the instrument is powered. Power off the instrument before installing the communication card. After the communication card is installed, power on the instrument. At this time, the instrument takes about 30 seconds to update the communication board automatically.**



- **Cabinet Installation**

This series of instruments can be mounted on a standard 19-inch cabinet. ITECH has prepared a special bracket as a mounting kit for users. For the installation method, refer to "IT-E158 User Manual".

Model	Installation Location	Description
IT-E158A	Two instruments mounted side-by-side. For fixing the front of the equipment to the cabinet.	It can be used with IT-E158B and adapted to ITECH cabinet.
IT-E158B	Two instruments mounted side-by-side. For fixing the rear of the equipment to the cabinet.	It can be used with IT-E158A and adapted to ITECH cabinet.
IT-E158C	Installation of a single instrument into a cabinet. For fixing the front of the equipment to the cabinet.	Used in conjunction with IT-E158D. For use in cases where only one instrument is installed on one floor.
IT-E158D	Installation of a single instrument into a cabinet. For fixing the rear of the equipment to the cabinet.	Used in conjunction with IT-E158C. For use in cases where only one instrument is installed on one floor.

- **Multi-channel Cascade**

IT-E168: For multi-channel synchronization or fiber optic triggering. Includes an optical module and two fiber optic cables of 1.5m and 0.3m length respectively.

# 2 Inspection and Installation

- ◆ Verifying the Shipment
- ◆ Instrument Size Introduction
- ◆ Rack Installation
- ◆ Connecting the Power Cord
- ◆ Connecting the Device Under Test (DUT)
- ◆ Remote Interface Connection

## 2.1 Verifying the Shipment

Unpack the box and check the contents before operating the instrument. If wrong items have been delivered, if items are missing, or if there is a defect with the appearance of the items, contact the dealer from which you purchased the instrument immediately.

The package contents include:

Item	Qty.	Remarks
Graphical Source Measure Unit	1	Please refer to <a href="#">1.7 Models and Options</a> for the detailed models.
Power Cord	1	Power cord that matches the specifications of power socket used in the area. See the Section <a href="#">2.4 Connecting the Power Cord</a> for details.
Interlock short cable	1	Short cable between Pin21 and Pin22 of the Digital IO terminal on the rear panel. By shorting these 2 pins, the SMU can set and output more than $\pm 42V$ .
USB communication cable	1	It is used to connect to a computer for communication.
Calibration Certificate	1	It is the calibration certificate of the instrument before delivery.



**Note**

Upon verification of the shipment, keep the package and relevant contents thereof in a safe place. When returning the instrument for warranty service or repair, the specified packing requirements shall be met.

## 2.2 Instrument Size Introduction

The instrument should be installed at well-ventilated and rational-sized space. Please select appropriate space for installation based on the instrument size.

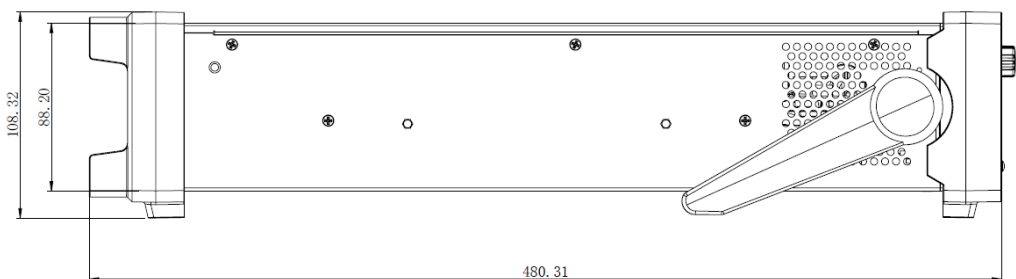
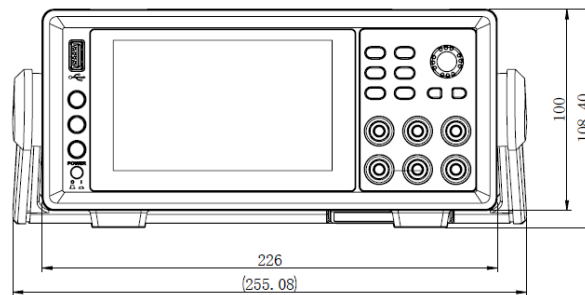
The dimensions of this series of SMU including the handle and rubber protective cover are shown in the figure below. Unit: mm.



The dimensions of IT2801, IT2805, and IT2806 models after removing the handle and rubber protective cover are shown in the figure below:

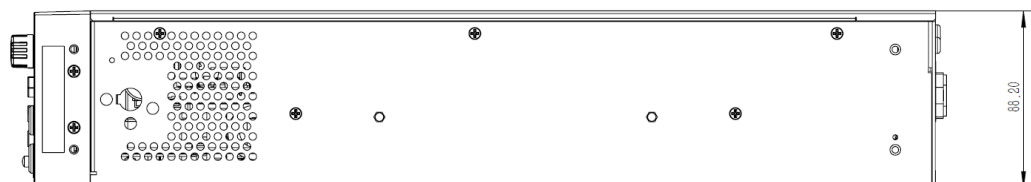

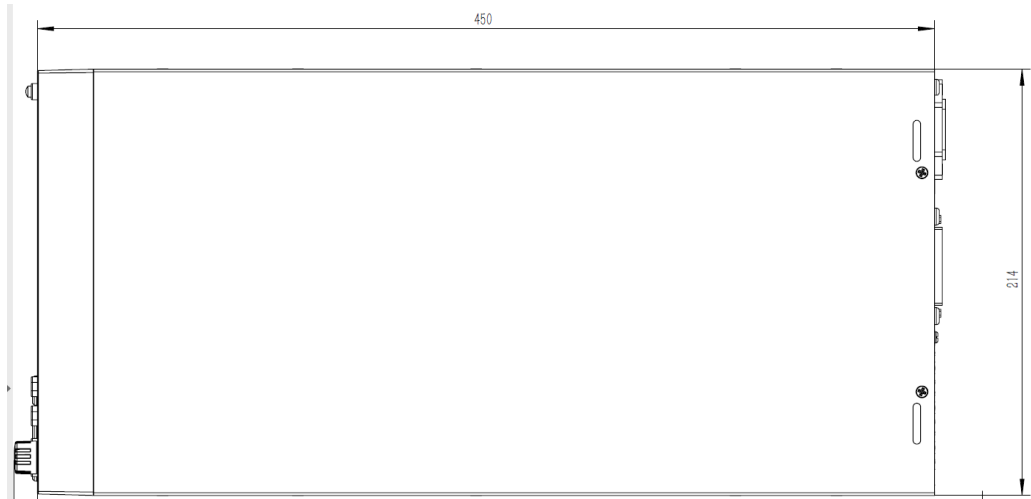

The size of the IT2801R model after removing the handle and rubber protective cover is shown in the figure below:

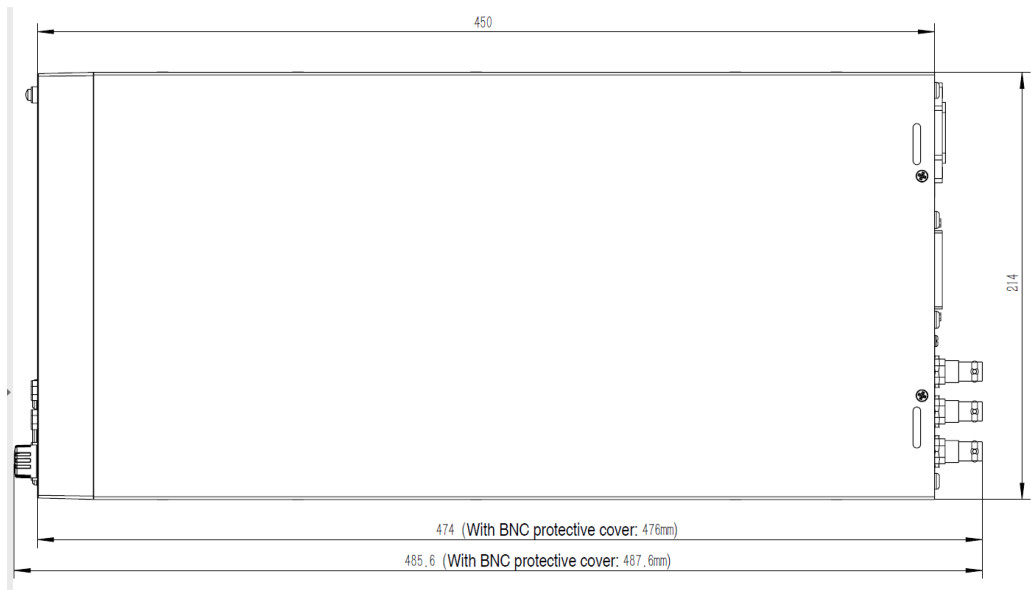
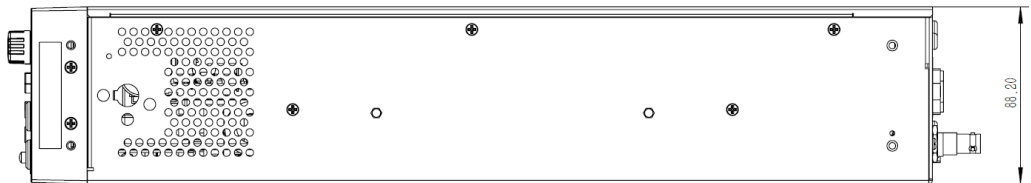

The dimensions of IT2805R and IT2806R models after removing the handle and rubber protective cover are shown in the figure below:

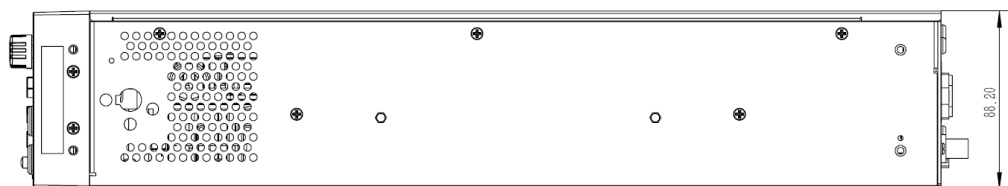

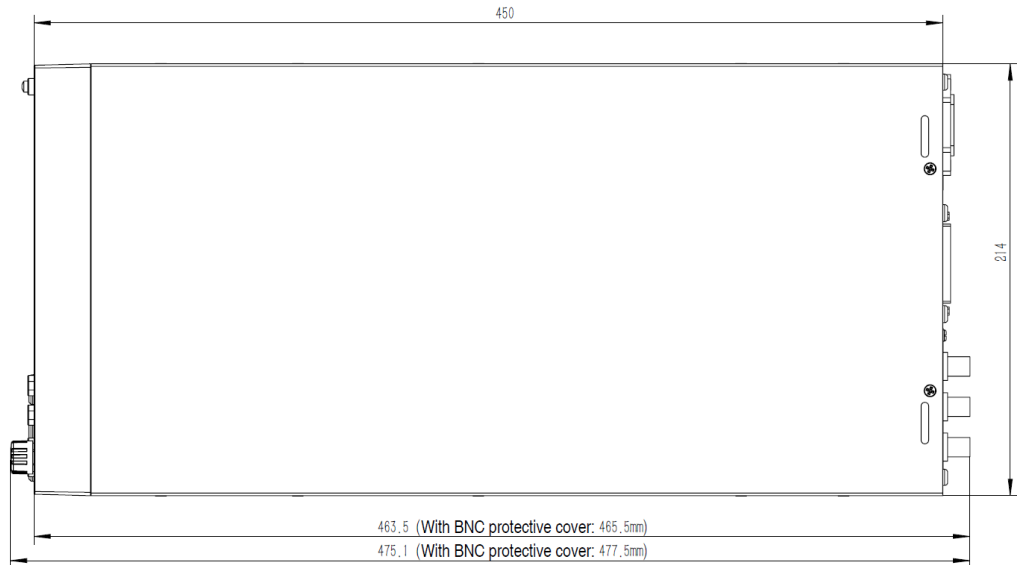

## 2.3 Rack Installation

The IT2800 series SMU can be installed on standard 19-inch rack. ITECH provides user with optional mount kit IT-E158. The detailed operation please refer to the *IT-E158 User Manual*.

Remove the front and rear rubber bumpers and the handle before rack mounting the IT2800.

### WARNING

**Do not block the air intake at the sides and the exhaust at the rear of the IT2800.**

### Removing the Bumper

Stretch a corner of the rubber bumper and slide it off.

### Removing the Handle

1. Grab the handle by the sides and pull outward. This will allow you to rotate the handle.
2. Rotate the handle to a vertical position. Then, position the instrument horizontally.
3. Pull outward and then lift the handle upward.

**CAUTION**

When reattaching the handle, pay attention to its direction. Incorrect attachment may damage the hardware.

---

## 2.4 Connecting the Power Cord

### Precautions

To prevent electric shock and damage to the instrument, observe the following precautions.

**WARNING**

- The power cords supplied with this product is certified for safety. In case the supplied lines assembly needs to be replaced, or an extension lines must be added, be sure that it can meet the required power ratings of this product. Any misuse voids the warranty of this product.
  - Before connecting power cord, be sure to confirm that the power voltage matches with the rated voltage.
  - Before connecting power cord, be sure to switch off the instrument. Power switch is in Off position.
  - To avoid fire or electric shock, make sure to use the power cord supplied by ITECH.
  - Do not use an extended power cord without protective grounding, otherwise the protection function will fail.
  - Be sure to connect the main power socket to the power outlet with protective grounding. Do not use terminal board without protective grounding.
- 

### Categories of Power Cords

The standard power cord types are as follows. Please select appropriate power cords appropriate to local voltage based on the specifications of power cords below. If purchased model fails to meet local voltage requirements, please contact distributor or factory for change.

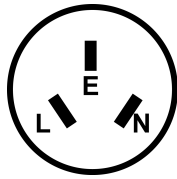

China  
IT-E171

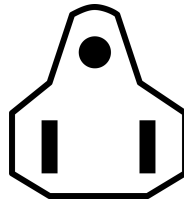

United States &  
Canada & Japan  
IT-E172

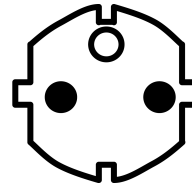

Europe  
IT-E173

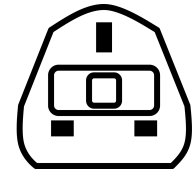

England  
IT-E174

## AC Power Input Level

The AC input on the back of your instrument is a universal AC input. It accepts nominal line voltages in the range of 90 to 260VAC. A frequency of 50 Hz or 60 Hz is required.

## Setting the Power Line Frequency

The power line frequency must be set properly for the AC power at your site. Press the following function keys to set the frequency to 50 Hz or 60 Hz.

- For setting to 50 Hz: Menu > System > PLC > 50 Hz
- For setting to 60 Hz: Menu > System > PLC > 60 Hz

## Connecting the Power Cord

To connect the power cord:

1. Make sure that the front-panel power switch is in the OFF position.
2. Connect the female end of the power cord to the AC receptacle on the rear panel.
3. Connect the plug of the power cord to a grounded AC outlet.

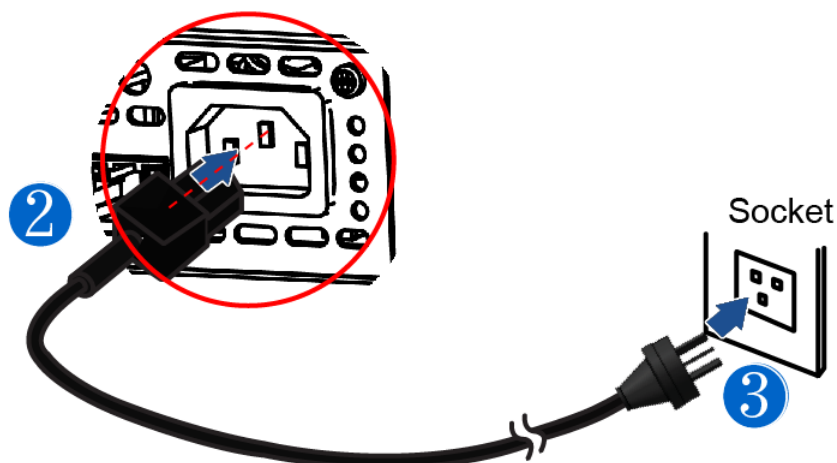

## 2.5 Connecting the Device Under Test (DUT)

When connecting a DUT, you can choose the connection type either 2-wire connections or 4-wire connections.

If you want to simplify the connections, use 2-wire connections by connecting the Force terminals only **and opening the Sense terminals**. The Force terminals can be used to apply and measure DC voltage or current.

If you want to use "remote measurement", after connecting the test cables, be sure to turn on the Sense function. The specific method is: set

**Menu**→**Config**→**Measure** →**Sensing Type** to **4 – Wires**.

To make 4-wire connections, remote sensing, well known as Kelvin connections, use both Force and Sense terminals. Connecting the Force and Sense cables together at the terminal of the DUT minimizes the measurement error caused by the residual resistance of the test leads or cables. This connection is effective for low resistance measurements and high current measurements.

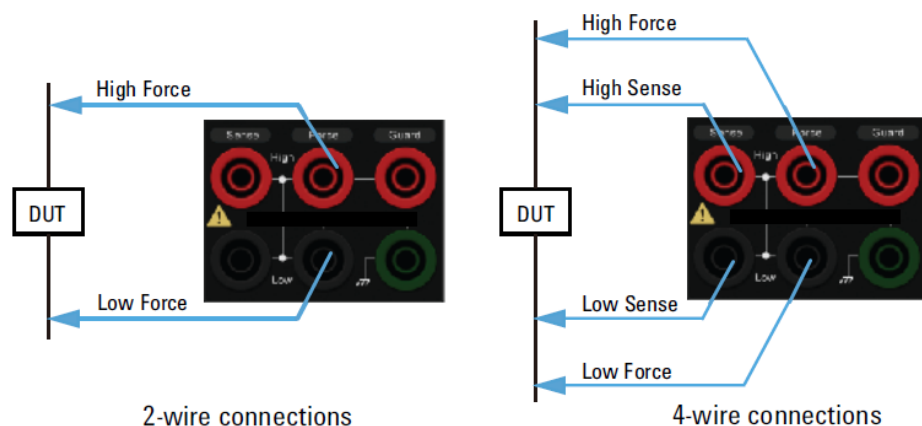

Low current measurements ( $<1\text{nA}$ ) require additional protection to prevent current leakage through the measurement cable. The following schematic diagram provides a brief overview of the guarding technique. Guarded measurements require the use of a triaxial cable. A (x1) follower buffer amplifier keeps the guard conductor at the same potential as the center conductor. Since there is no voltage difference, no current flows from the center conductor to the guard conductor. **Note: In this example, even the test fixture is equipped with a protective shield to prevent leakage in the test fixture.**

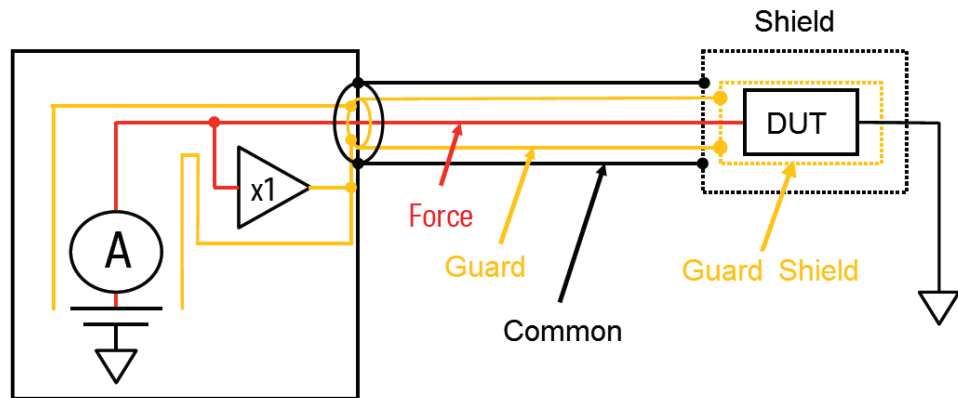

## Precautions

To prevent electric shock and damage to the instrument, observe the following precautions.

### WARNING



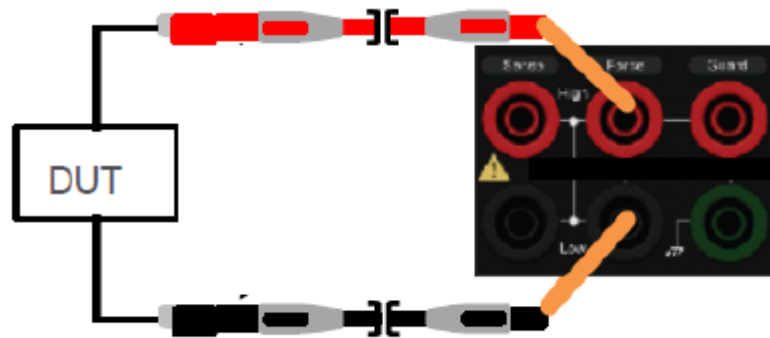

- **Before connecting test cables, be sure to switch off the power supply. Power switch is in Off position, otherwise touching the output terminals may result in personal injury or death due to electric shock.**
- **To avoid electrical shock, before testing, please make sure the rating values of the testing cables, and do not measure the current that higher than the rating value. All test cables shall be capable of withstanding the maximum short circuit output current of the power supply without causing overheat.**
- **If several loads are provided, each pair of load wires shall safely withstand the rated short circuit output current of the power supply under full load.**
- **To avoid battery short circuit, be sure to check that the test cable end is not connected when connecting or disassembling the test cable. When the test cable end is connected with battery, short circuit may cause severe accident.**
- **Please check that the test cables can withstand maximum current.**
- **During wiring, check that the anode and cathode of the test cables are properly and tightly connected; anode ON and cathode OFF are prohibited.**

This series SMU can be connected for testing using the 2-Wires method, as shown in the figure below.

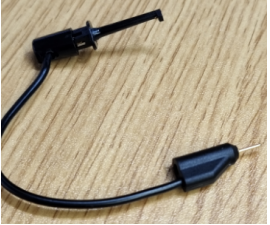

For scenarios with higher testing requirements, please purchase the following options separately:

Model	Description	Image
IT-E801A	Banana to 4–Wire triaxial adapter. Suitable for IT2805, IT2805R, IT2806, IT2806R. See <a href="#">2.5 Connecting the Device Under Test (DUT)</a> for details.	
IT-E802A	Banana to 4–Wire triaxial adapter. Suitable for IT2801, IT2801R. See <a href="#">2.5 Connecting the Device Under Test (DUT)</a> for details.	
IT-E801B	Banana to 2–Wire triaxial adapter. Suitable for IT2805, IT2805R, IT2806, IT2806R. See <a href="#">2.5 Connecting the Device Under Test (DUT)</a> for details.	

Model	Description	Image
IT-E801C-1.5	Low leakage triaxial cables. Length is 1.5m, suitable for IT2805, IT2805R, IT2806, IT2806R.	
IT-E802C-1.5	Low leakage triaxial cables. Length is 1.5m, suitable for IT2801, IT2801R.	
IT-E803	Component testing fixture, with measurement specifications up to 40V, 1A. It comes standard with six test cables, which include: <ul style="list-style-type: none"> <li>• Four cables, each 50mm in length, with one end featuring a 1mm pin plug and the other end equipped with a miniature clip;</li> <li>• Two cables, each 50mm in length, with 1mm pin plugs at both ends.</li> </ul>	  

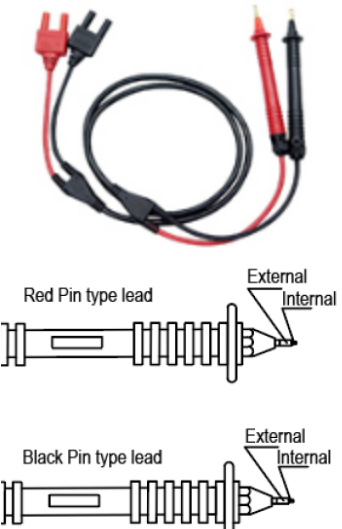
Model	Description	Image
IT-E804	<p>Test Fixture for Semiconductor Devices With measurement specifications up to 250V, 3A, and 10A Pulse. It comes standard with nine test cables, which include:</p> <ul style="list-style-type: none"> <li>• One cable, 1500mm in length, featuring two DB25 connectors on one end and an aviation plug on the other;</li> <li>• Four cables, each 100mm in length, with one end featuring a 1mm pin plug and the other end equipped with a miniature clip;</li> <li>• Four cables, each 100mm in length, with 1mm pin plugs at both ends.</li> </ul>	 <p>The image block contains four photographs. The top photo shows the IT-E804 test fixture, a black rectangular unit with various ports and connectors on its front panel. Below it are three smaller photos showing different types of test cables: a long cable with DB25 connectors and an aviation plug, and two shorter cables with 1mm pin plugs at both ends.</p>
IT-E601	<p>Kelvin (4-wire) test cable. 300V banana to pin plug (- Crown Round Tip) connection cable (black), suitable for IT2805, IT2805R, IT2806, IT2806R.</p>	 <p>The image block contains a photograph and two diagrams. The photograph shows a black 4-wire test cable with red and black leads, one ending in a banana plug and the other in a pin plug. Below the photo are two diagrams of the pin plug connector. The top diagram is labeled 'Red Pin type lead' and the bottom diagram is labeled 'Black Pin type lead'. Both diagrams show the internal structure of the pin plug, with labels for 'External' and 'Internal' connections.</p>

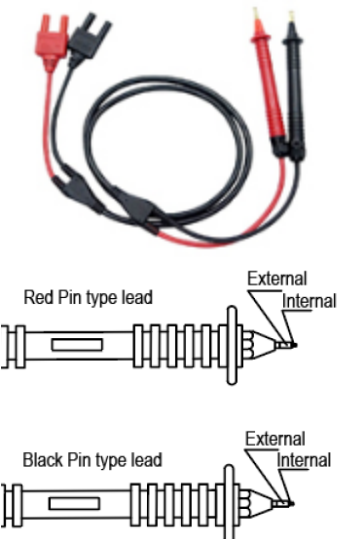
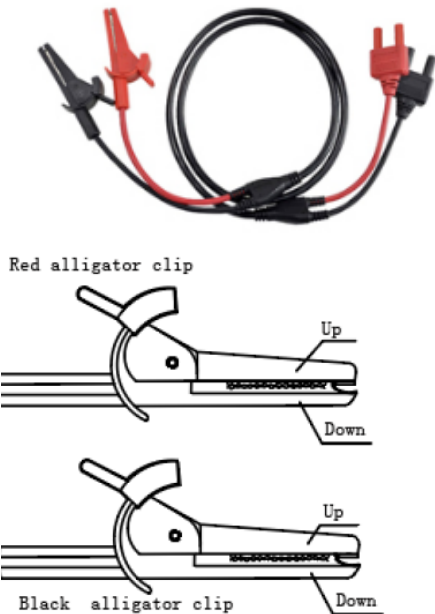
Model	Description	Image
IT-E601H	Kelvin (4-wire) test cable. 1000V banana to pin plug (- Crown Round Tip) connection cable (black), suitable for IT2801, IT2801R.	 <p>Red Pin type lead</p> <p>External Internal</p> <p>Black Pin type lead</p> <p>External Internal</p>
IT-E602	Kelvin (4-wire) test cable. 300V banana to alligator clip connection cable (black), suitable for IT2805, IT2805R, IT2806, IT2806R.	 <p>Red alligator clip</p> <p>Up Down</p> <p>Black alligator clip</p> <p>Up Down</p>

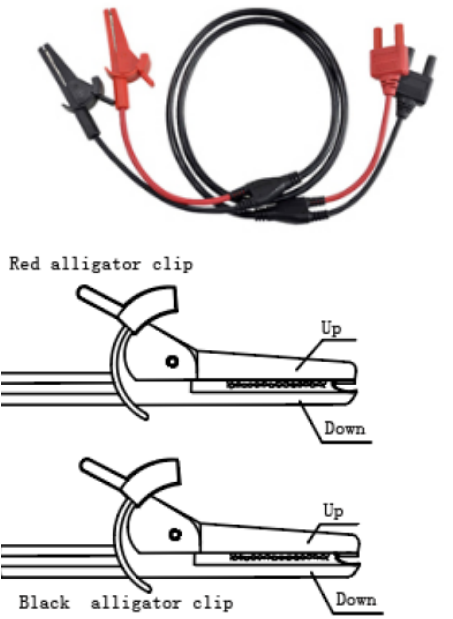
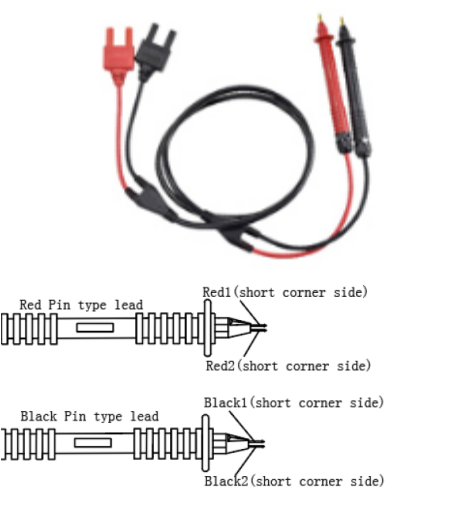
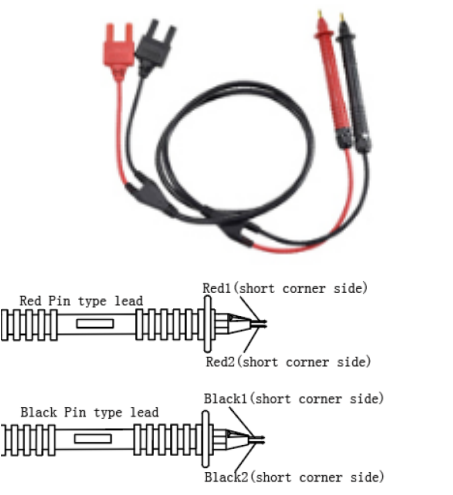
Model	Description	Image
IT-E602H	Kelvin (4-wire) test cable. 1000V banana to alligator clip connection cable (black), suitable for IT2801, IT2801R.	 <p>Red alligator clip</p> <p>Up</p> <p>Down</p> <p>Black alligator clip</p> <p>Up</p> <p>Down</p>
IT-E603	Kelvin (4-wire) test cable. 300V banana to pin plug (- Cone Tip) connection cable (- black), suitable for IT2805, IT2805R, IT2806, IT2806R.	 <p>Red Pin type lead</p> <p>Red1 (short corner side)</p> <p>Red2 (short corner side)</p> <p>Black Pin type lead</p> <p>Black1 (short corner side)</p> <p>Black2 (short corner side)</p>
IT-E603H	Kelvin (4-wire) test cable. 1000V banana to pin plug (- Cone Tip) connection cable (- black), suitable for IT2801, IT2801R.	 <p>Red Pin type lead</p> <p>Red1 (short corner side)</p> <p>Red2 (short corner side)</p> <p>Black Pin type lead</p> <p>Black1 (short corner side)</p> <p>Black2 (short corner side)</p>

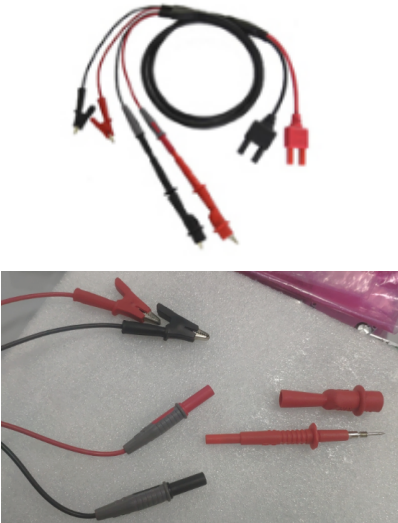
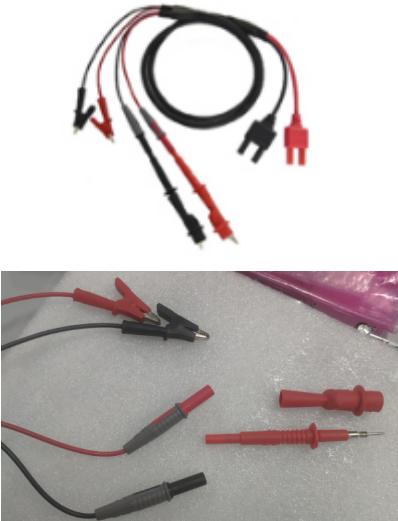
Model	Description	Image
IT-E604	Kelvin (4-wire) test cable. 300V banana to universal pin and alligator clip connection cable (black), suitable for IT2805, IT2805R, IT2806, IT2806R.	
IT-E604H	Kelvin (4-wire) test cable. 1000V banana to universal pin and alligator clip connection cable (black), suitable for IT2801, IT2801R.	

## Connecting the interlock circuit

The IT2801 model of the IT2800 series SMU has a maximum output voltage of up to 1000VDC. To maximize the safety of the DUT as well as the user's personal safety, the IT2800 provides an interlock function to prevent the user from receiving an electrical shock from high voltages over  $\pm 42$ VDC. If the Digital I/O interlock terminal (Pin21 and Pin22) is open, IT2800 cannot apply a high voltage. The IT2800 can only output the rated voltage after the Interlock terminals (Pin21 and Pin22) are shorted.

## 2-Wire Connections

The connection diagram of the DUT during local measurement is shown below.

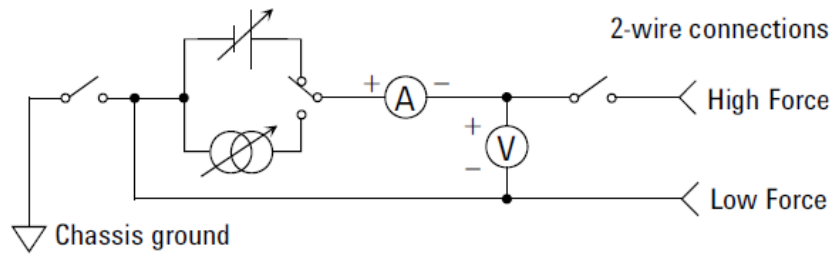

**Note**

In order to ensure the accuracy of measurement, it is recommended to operate the instrument **an hour** after start-up.

**4-Wire Connections**

The connection diagram of the DUT during remote measurement is shown below.

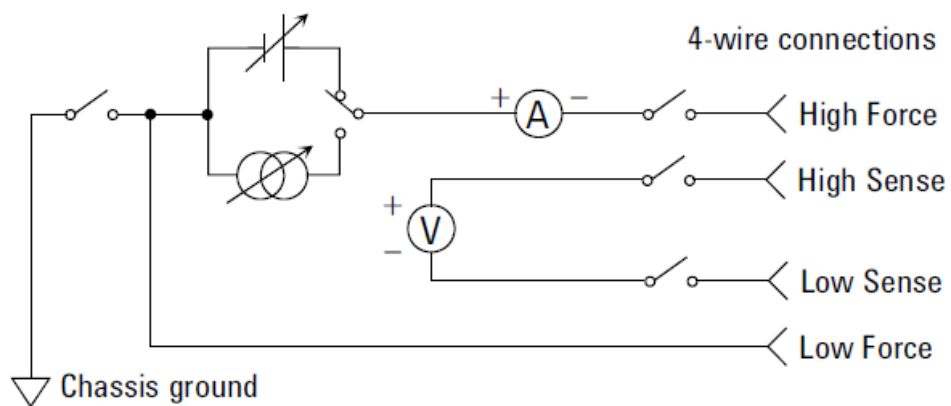

**Note**

In order to ensure the accuracy of measurement, it is recommended to operate the instrument **an hour** after start-up.

**Guarding**

Guarding reduces the leakage current between the instrument and a DUT. This is important when you measure a low current.

The figure below shows the theory of guarding. The buffer amplifier (X1) keeps the potential of the Guard conductor at the same potential as the High Force conductor, so that the current does not flow between the High Force and Guard conductors. Therefore, the current measured by the instrument is the same as the current at the DUT terminal because no current is leaked.

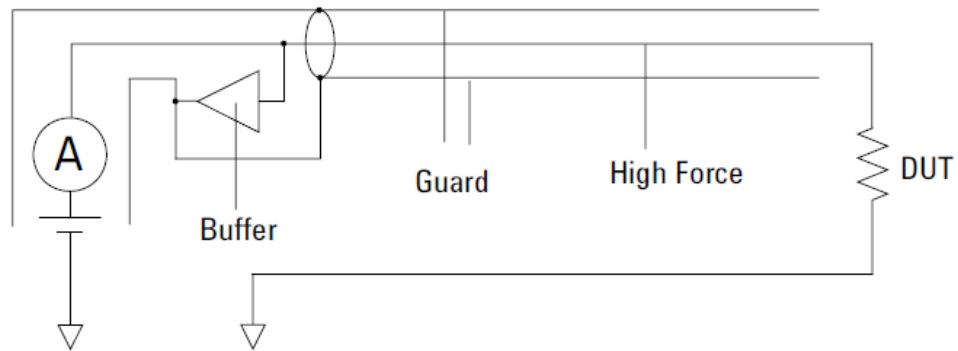
**WARNING**

Never connect the Guard terminal to any output, including circuit common, chassis ground, or any other guard terminal. Doing so will damage the IT2800.

### IT2800R model rear panel BNC terminals

The IT2801R, IT2805R, and IT2806R models come with BNC terminals on the rear panel, and the pin definitions are shown below.

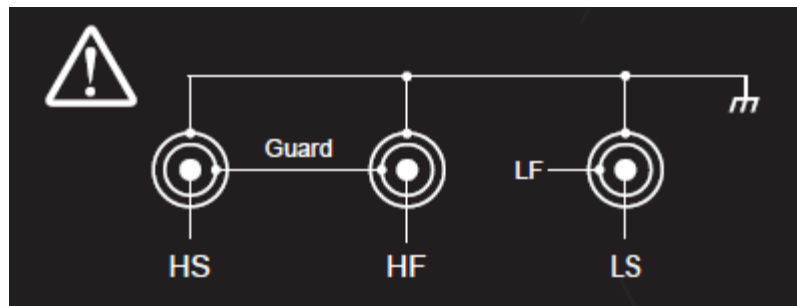

Wiring methods:

- Two-wire: Connect HF (High Force) and LF (Low Force) to the DUT.
- Four-wire: Connect HF (High Force), HS (High Sense), LF (Low Force), and LS (Low Sense) to the DUT.

### 4-wire banana plug to triaxial adapter

The pin definitions for the four-wire banana plug to triaxial adapter are as follows:

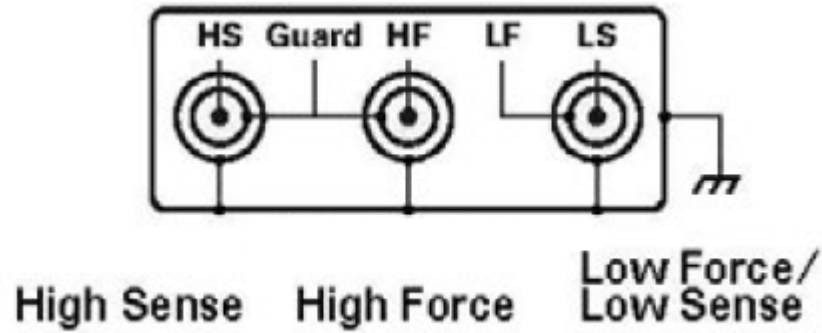

Take the IT2801 model as an example and use the IT-E802A with 3 IT-E802C-1.5 cables. Refer to the diagram below for connection.

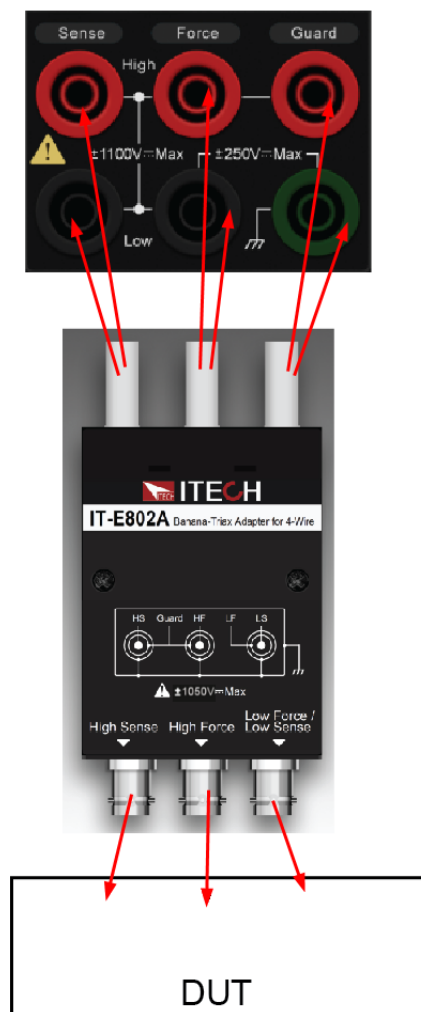

### 2-wire banana plug to triaxial adapter

The pin definitions for the 2-wire banana plug to triaxial adapter are as follows:

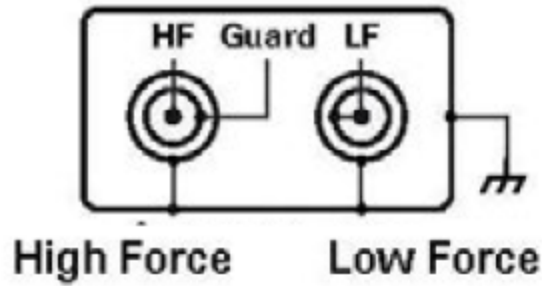

Take the IT2805 model as an example and use the IT-E801B with two IT-E801C-1.5 cables (both ends have BNC terminals). Refer to the diagram below for connection.



### IT-E803 Connection

The IT-E803 is a test fixture which has four triaxial connectors which allows to make two 2-wire connections. After opening the top cover, as shown in the diagram below.

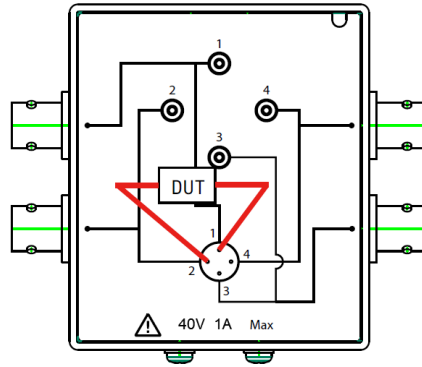

The IT-E803 requires pairing with the IT-E801B banana plug to triaxial adapter (2-wire) and triaxial cables. The wiring method is shown in the diagram below.

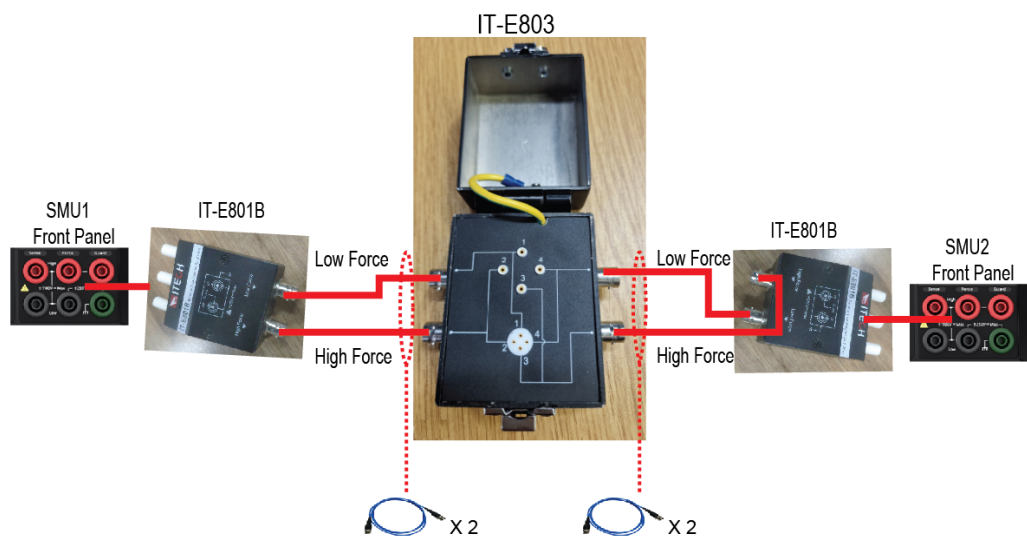

To connect to the IT-E803 test fixture for the device of three terminals such as Bipolar Junction Transistor (BJT), four IT-E801C-1.5 Triaxial cables are required.

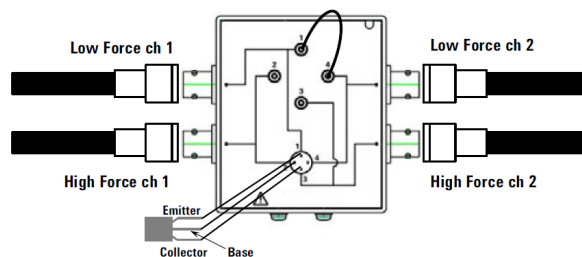
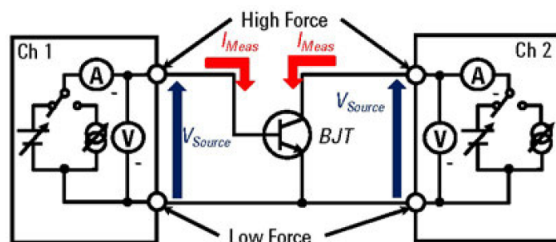

**CAUTION**
**Attention Shielding**

The IT-E803 is equipped with the lid. To minimize the affect of ambient noise, close the lid when performing the measurement.

**IT-E804 Connection**

The IT-E804 test fixture is designed for testing packaged devices and electronic components. The IT-E804 has six triaxial connectors (BNC type) for source/measure unit (SMU), and the Interlock connector for the interlock control.

The IT-E804 requires pairing with the IT-E801A banana plug to triaxial adapter (4-wire) and triaxial cables. The wiring method is shown in the diagram below.

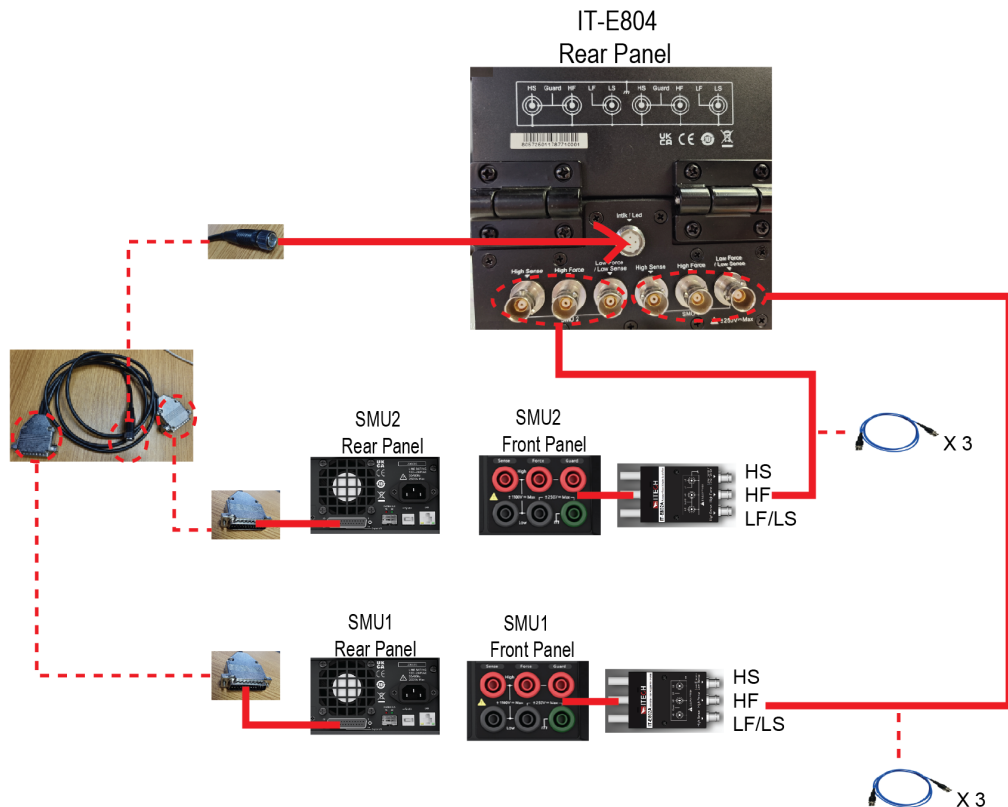

Below is an example of connecting a three-terminal device to a 2-channel SMU using six IT-E801C-1.5 triaxial cables. Connect a Bipolar Junction Transistor (BJT) or other three-terminal device to the IT-E804 test fixture to measure the characteristics of the collector current and base voltage of the BJT, as well as tests with constant  $V_{ce}$ .

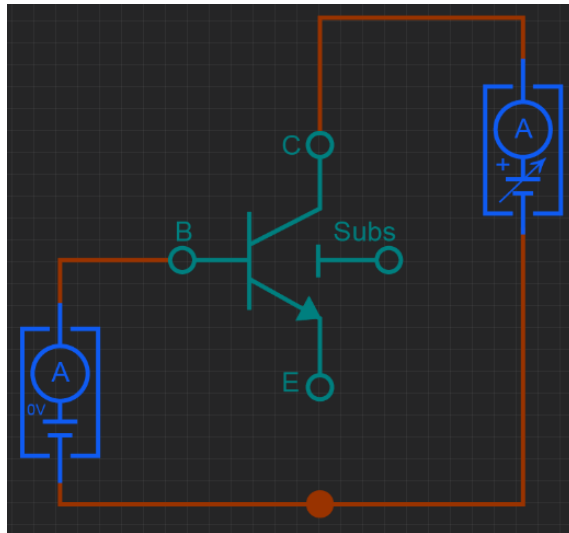

IT-E804  
Test Board

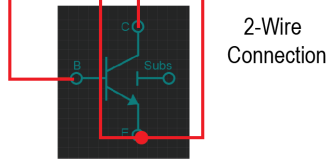
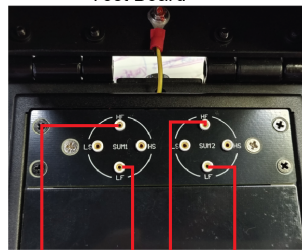

IT-E804  
Test Board

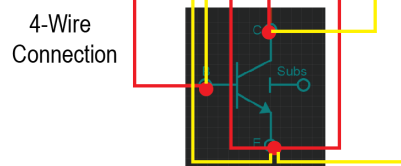
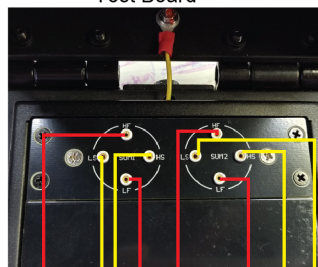

**CAUTION**

- **Attention Shielding**

The IT-E804 is equipped with the lid. To minimize the affect of ambient noise, close the lid when performing the measurement.

- **Performing High Voltage Measurement**

When the Digital I/O interlock terminal is open, the SMU cannot apply high voltage over  $\pm 42$  V. To perform the high voltage measurement, the SMU must be connected to the interlock circuit installed in the IT-E804. The SMU can apply the high voltage when the test fixture lid is closed.

## 2.6 Remote Interface Connection

This series SMU comes standard with two communication interfaces: USB and LAN. Additionally, the IT2801, IT2805, and IT2806 models support an optional GPIB interface card (IT-E176). Users can choose any of these interfaces to establish communication with a computer.

### 2.6.1 USB Interface

The operation steps for using the USB interface are as follows.

1. Use a USB cable to connect the instrument and the computer.
2. Select the USB interface type in the System menu.
  - a. Select **Menu**→**System** to enter the system menu page.
  - b. Select the **Communication** tab.
  - c. Use the left/right arrow keys or turn the knob to select **USB Type**, then press the **[Enter]** key to confirm.

When using USB communication, make sure that **USB Type** is set to **Device**.

- d. Select the USB interface type **USB Device**, and press the **[Enter]** key to confirm.
  - **TMC**: TMC communication mode. You need to download and install the NI-VISA driver compatible with your PC's operating system from

the NI official website. Once successfully installed, a USB-TMC device address will appear in the Device Manager.

- **VCP:** Virtual COM Port. For this type, Windows 7 systems require the corresponding driver (available on the ITECH official website or by contacting ITECH). After installation, "Prolific USB-to-Serial COM Port" will appear in the Device Manager. For Windows 10 and above, no VCP driver installation is needed.
- e. After completing the settings, press the **[Esc]** key to return.

## 2.6.2 LAN Interface

### LAN Connection

Follow the steps below to quickly connect the instrument to a local area network (LAN) and configure it. The description below illustrates two typical LAN interface systems: a dedicated network and a site network.

- **Connecting to a Dedicated LAN**

A dedicated LAN refers to a network formed by directly connecting a LAN-supported instrument to a computer. Dedicated LANs are usually small and not centrally managed. When connecting to a computer, a standard network cable can be used to connect the instrument directly to the computer via the LAN interface.

- **Connecting to a Site LAN**

A site LAN refers to a local area network in which LAN-supported instruments and computers are connected through routers, hubs, and/or switches. Site LANs are usually large, centrally managed networks that include services such as DHCP and DNS servers. When connecting to a computer, a standard network cable can be used to connect the instrument to the router, with the computer also connected to the same router.



#### Note

- When connecting to a dedicated LAN, the gateway address must be the same as the computer's gateway address, and the IP address must be in the same subnet as the computer's IP address.
- When connecting to a site LAN, the computer should be on the same IP subnet as the WLAN port of the router, while the instrument should be on the same subnet as the LAN port of the router.

### LAN Status Indicators

The figure below shows the two status LEDs located at the bottom of the LAN port.

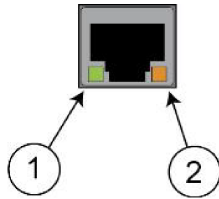

If both indicators are off, it means the network is not connected.

- Position 1: When lit, it indicates that a connection has been established on the LAN port.
- Position 2: When blinking, it indicates that data is being received or transmitted through the LAN port.

## Configure LAN Interface Parameters

By default, DHCP is enabled at the factory, which allows communication over LAN. DHCP stands for Dynamic Host Configuration Protocol, a protocol that assigns dynamic IP addresses to network devices. With dynamic addressing, a device can have a different IP address each time it connects to the network. This is usually the simplest way to configure LAN. Communication parameters for the LAN interface can be configured in the System menu.

- Automatically Assign Instrument Address (DHCP)

If selected, the instrument will first attempt to obtain an IP address from a DHCP server. If a DHCP server is found, it will assign an IP address, subnet mask, and default gateway to the instrument. If no DHCP server is available, the instrument will attempt to use AutoIP to obtain an IP address. AutoIP automatically assigns an IP address, subnet mask, and default gateway on networks without a DHCP server.

- Manually Assign Instrument Address (Manual)

This method requires setting the following parameters, which are only displayed when Manual is selected.

- IP: This is the instrument's IP (Internet Protocol) address. All IP and TCP/IP communication with the instrument requires an IP address. The IP address consists of four decimal numbers separated by dots. Each number ranges from 0 to 255 without leading zeros (e.g., 169.254.2.20).  
**Default: 192.168.200.100**
- Mask: This value allows the instrument to determine whether the client's IP address is on the same local subnet. The same number format is suitable for use as an IP address. If the client IP address is on a different subnet, all packets must be sent to the default gateway.
- Gateway: This is the IP address of the gateway used by the instrument to communicate with systems outside the local subnet, depending on the

subnet mask. The same number format is suitable for use as an IP address. A value of 0.0.0.0 indicates no default gateway is specified.

- Port: This value represents the port number used for the RawSocket service. Valid range: 10000–60000, default: 30000.

#### Steps to configure:

1. Select **Menu**→**System** to enter the system menu page.
2. Select the **Communication** tab.
3. Use the left/right arrow keys or turn the knob to select **Mode**, then press **[Enter]** to confirm.
  - DHCP: Automatically assign instrument address.
  - Manual: Manually assign instrument address.

If Manual is selected, parameters such as IP, Mask, Gateway, and Port must be set.
4. After configuration is complete, press the **[Esc]** key to return.

### Restore LAN Factory Defaults

To restore the LAN settings to factory defaults, use the **Factory Default Setting** option to reset all parameters in the Menu to their factory values.

1. Select **Menu**→**System** to enter the system menu page.
2. Select the **General** tab.
3. Use the left/right arrow keys or turn the knob to select **Factory Default Setting**, then press the **[Enter]** key to confirm.
4. After completion, press the **[Esc]** key to return.

#### 2.6.2.1 Use Web Function

The instrument provides a built-in web server, allowing you to monitor and control the instrument directly from a computer's web browser. To use the web server, connect the instrument and the computer via the LAN interface, then enter the instrument's IP address into the address bar at the top of the web browser to access the front panel control functions, including LAN configuration parameters.

The format to enter in the browser's address bar is: `http://192.168.200.100`

**192.168.200.100** is the default IP address. If it has been modified, replace it with the actual IP configured in the instrument's Menu.

**Note**

- In Web Control mode, the instrument's panel buttons remain functional.
- The instrument supports simultaneous connection with up to six computers. Connecting more than six may degrade performance.

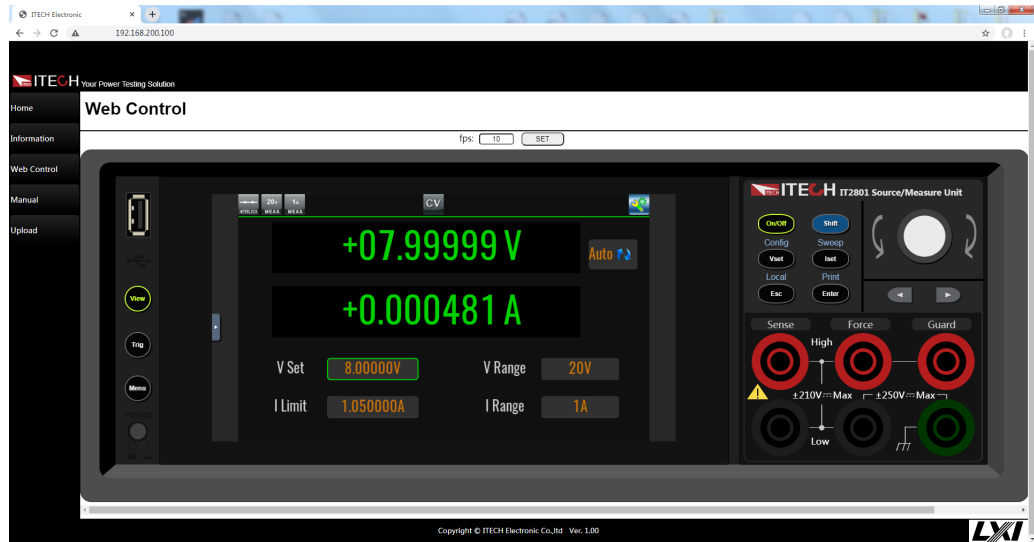

Click the buttons in the navigation bar on the left side of the window to switch between different interface screens. Details are as follows:

- Home: The main web interface, displaying the instrument model and appearance.
- Information: Displays system information such as the instrument serial number and LAN configuration parameters.
- Web Control: Enables remote Web Control of the instrument. On this screen, you can monitor and control the instrument.
- Manual: Redirects to the ITECH official website to view or download documentation related to the instrument.
- Upload: Upgrade firmware via the web interface.

Click **CONNECT** to connect the PC to the instrument, then click **Select File** to choose the firmware upgrade package (e.g., **IT2800-U-V000.001.030all.itech**), and click **UPLOAD** to perform the upgrade. After the upgrade is complete, the instrument must be restarted.

### 2.6.2.2 Using Sockets

**CAUTION**

**The instruments allow up to six simultaneous socket connections to be made.**

ITECH instruments have SCPI socket services, which can be used to send and receive SCPI commands, queries, and query responses. All commands must be terminated with a newline for the message to be parsed. All query responses will also be terminated with a newline.

### 2.6.3 GPIB Interface (Optional)

When the optional interface card is a GPIB interface (IT-E176), please note the following information.



#### Note

**Only IT2801, IT2805, and IT2806 support the optional GPIB interface. IT2801R, IT2805R, and IT2806R do not support the GPIB card option.**

Each device on the GPIB interface must have a unique integer address between 0 and 30. The address of your computer's GPIB interface card must not conflict with any instrument on the interface bus. This setting is non-volatile; it is not affected by **\*RST**.

The steps for using the GPIB interface are as follows.

1. Make sure the instrument's power switch is turned off (Power Off state).
2. Insert the separately purchased GPIB interface card into the card slot on the instrument's rear panel.
3. After inserting the IT-E176 card into the rear panel, connect it to your computer using an IEEE-488 bus cable.

Ensure full contact and tighten the screws securely.

4. Change the GPIB address in the System menu.
  - a. Select **Menu**→**System** to enter the system menu page.
  - b. Select the **Communication** tab.
  - c. Use the left/right arrow keys or turn the knob to select **GPIB**, then press the **[Enter]** key to confirm.
  - d. Turn the knob to adjust the GPIB address to the desired value, then press **[Enter]** to confirm.
  - e. After completing the setup, press the **[Esc]** key to return.

# 3 Function Details

This chapter will describe in detail the functions and features of the instrument. It will be divided into the following sections:

- ◆ Scope Mode
- ◆ Recorder Mode
- ◆ Measure Limit
- ◆ Battery Simulation
- ◆ Synchronous On/Off Function
- ◆ Protection Functions in Detail
- ◆ Sweep Function
- ◆ Config Menu Function
- ◆ Meas ohms Function
- ◆ Meas math Function
- ◆ Trace Function
- ◆ Trigger Function
- ◆ Fiber Optic Synchronization Trigger Function

## 3.1 Scope Mode

### Function Introduction

The waveform display function is used to capture voltage and current data during high-speed operation and plot these data into easy-to-observe curves. The captured data can also be exported in CSV file format to a U disk storage device.

### Parameters

#### Scope display parameters

Parameter	Description	Range
State	Scope operating status indication	Stop: Scope running stop. Color: Red
		Ready: Scope enters the waiting state. Color: Yellow
		Roll: Enter scanning mode when the time base is greater than or equal to 50ms. Color: Yellow
		Auto: Auto mode automatically generates a trigger at regular intervals when

Parameter	Description	Range
		no external Trig is received. Color: Yellow
		Trig'd: in trigger state. Color: Green
Curve Selection State	Display curve status	U: Voltage curve. Color: Yellow
		I: Current curve. Color: Red
Trigger State Mode	Displays the trigger source and the trigger edge	U: The trigger source is the voltage.
		I: The trigger source is current.
		↑: Rising edge triggered.
		↓: Falling edge triggered.
		↑↓: Both rising/falling edges can be triggered.
		M: The trigger source is manual trigger.
		B: The trigger source is command trigger.
		T1: The trigger source is Trigger-1.
		T2: The trigger source is Trigger-2.
		F1: The trigger source is Filber-1.
Navigation display	Displays the data length in equal proportions, as well as the trigger point.	White interval: Narrowed by 1:3 ratio with the waveform display interval.
		White horizontal line: the data length is displayed equivalently in the interval.
		Yellow icon T: Equivalent display of the trigger time position.

### Scope setting parameters

Parameter	Description	Range
Voltage Div V/	Voltage amplitude per cell	Unit: change in order of $\mu\text{V}/\text{mV}/\text{V}/\text{kV}$ <b>Only the IT2801 and IT2801R models will display the unit kV.</b>
Current Div A/	Current amplitude per cell	Unit: change in order of $\text{pA}/\text{nA}/\text{uA}/\text{mA}/\text{A}$
Time Div S/	Time amplitude per cell	Unit: change according to $\text{ms}/\text{s}$
Trigger Source	Setting the trigger source	Source: Source change trigger. It indicates that a trigger signal is generated whenever any set output value is changed.
		Voltage: Voltage trigger.
		Current: Current trigger.
		Manual: Manual trigger. (Trigger by pressing <b>Trig</b> key)
		Bus: Command triggered ( <b>*TRG</b> command triggered)
		Trigger-1: Digital IO1 trigger.
		Trigger-2: Digital IO2 trigger.
Trigger Rise	Set edge trigger	Rise: Rising edge trigger.
		Fall: Falling edge trigger.
		Both: Triggered by rising and falling edges.
Trigger Mode	Setting the trigger mode	Auto and Normal can be selected
		Normal: voltage range, current range, time base, time offset, configured to generate trigger according to user set values.
		Auto: The trigger is automatically generated according to the Time Div timing.

Parameter	Description	Range
Recorder Length Maximum	Set the maximum data length	IT2801/IT2806: 600kpts/60kpts/6kpts/0.6kpts
		IT2805: 300kpts/60kpts/6kpts/0.6kpts
Print Mode	Set (Shift+Enter) keys to export data	BMP: Press (Shift+Enter) in the Scope screen to take a screenshot only without exporting data.
		BMP&Data: Press (Shift+Enter) in the Scope screen to take a screenshot and export the raw data at the same time.
Export To Udisk	Exporting raw data from Scope runs	File naming format: IT28XX_scope_raw_data0000XX
Sample Mode	Set the sampling mode.	Set the sampling mode, with options for <b>Normal</b> or <b>Peak</b> . This option can only be edited when <b>Recorder Length Maximum</b> is set to <b>600kpts</b> ; for other values, only <b>Normal</b> can be selected.
Trigger Delay	Trigger time setting	Trigger time setting range: ( $-3 \times \text{Time Div} \sim 3 \times \text{Time Div}$ )
Trigger Value	Set the trigger value when the trigger mode is Voltage or Current	Trigger range when Trigger Source is Voltage: ( $-2 \times \text{Voltage Div} \sim 2 \times \text{Voltage Div}$ )  Trigger range when Trigger Source is Current: ( $-2 \times \text{Current Div} \sim 2 \times \text{Current Div}$ )
Auto	Automatically set the appropriate waveform interval	Automatic adjustment of Voltage Div /Current Div.  Time Div is set to 10ms.  Trigger Delay is set to 0us.  Trigger Source is changed to Voltage.  Trigger Value is set to 0V.  Trigger Edge is changed to Rise.

Parameter	Description	Range
		Trigger Mode is changed to Auto. Run/Stop is set to Run.
Single	Set single trigger.	
Run/Stop	Set Scope running status	When Scope operation is stopped, Run/Stop is displayed in red and the status indication turns to Stop.

**Export file format**

<b>Model</b>	<b>IT2801</b>	
Sn	XXXXXXXXXXXXXXXXXXXX	
Voltage div	0.500000V	
Current div	1.000000A	
Time div	0.010000s	
Delay	0.000000s	
Sample interval	10us	
Trigger index	300	
<b>No</b>	<b>Voltage(V)</b>	<b>Current(A)</b>
0	0.410344	4.16E-11
1	0.392644	1.13E-10
2	0.410344	-1.90E-10
3	0.410344	-1.20E-11
4	0.410344	1.66E-10
5	0.410344	2.37E-11
6	0.410344	-4.05E-10
7	0.410344	-1.37E-10
8	0.428045	2.74E-10
9	0.445746	-1.01E-10
10	0.445746	-4.58E-10

11	0.374943	3.27E-10
...	...	...

## Display data length calculation

IT2801 and IT2806 Fastest Sample Rate = 10us; IT2805 Fastest Sample Rate = 20us.

Scope takes the total time to display each screen of data, Full Time = Time Div \*6.

Sample Interval= Full Time/ Recorder Length Maximum; If Sample Interval is less than 10us, Sample Interval defaults to 10us.

When the user uses the export data function, the total length of the original data displayed Data Length can be calculated according to the following formula:

Data Length = Full Time/ Sample Interval

**Example:** Model IT2801

**Condition 1:** Time Div = 1ms; Recorder Length Maximum = 600kpts

**Calculation 1:** Full Time = 6ms; Sample Interval = 6ms/600kpt < 10us; Therefore, Sample Interval = 10us ; Data Length = 6ms/10us = 600;

**Condition 2:** Time Div = 1s; Recorder Length Maximum = 60kpts

**Calculation 2:** Full Time = 6s; Sample Interval = 6s/60kpt = 100us; Data Length = 6s/100us = 60000;

## Interface Operation Introduction

**Waveform display setting interface:**

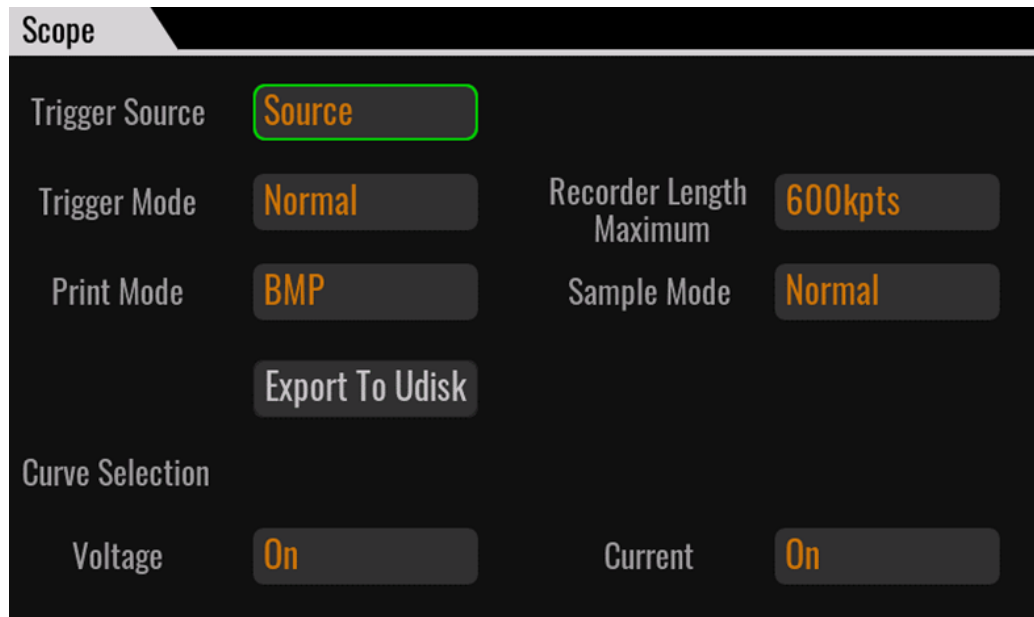

- Set Trigger Source to Voltage / Current to set Trigger Edge. When other trigger source is selected, Trigger Edge is not editable.
- Trigger Mode: User-defined setting of trigger mode and maximum data length for recording.
- Print Mode selects whether you want to export the raw data.
- Curve Selection sets the voltage and current curve status.

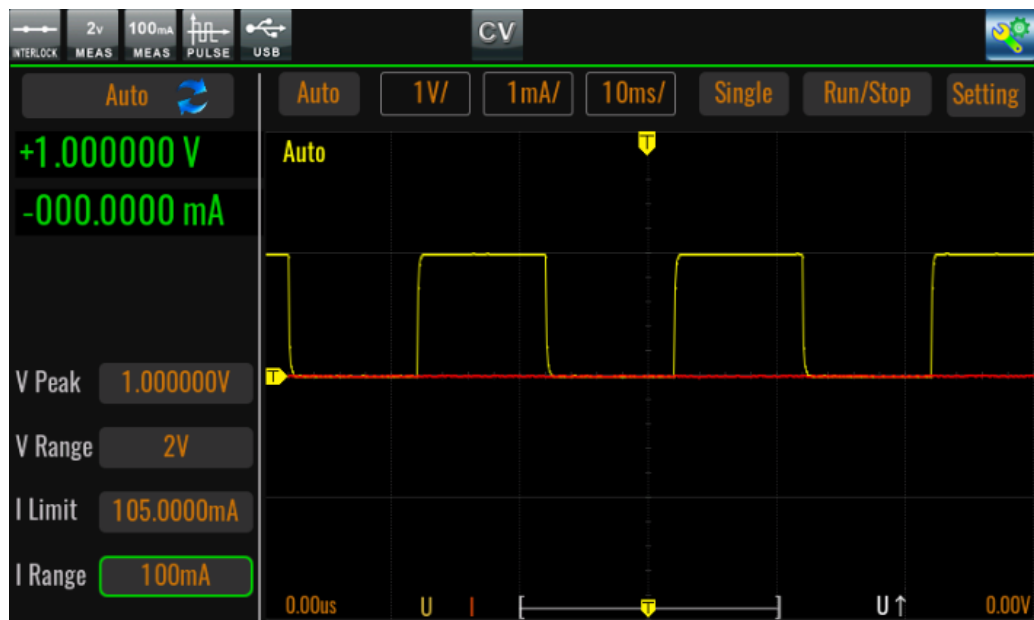

1. Set Voltage Div, Current Div, Time Div according to the actual demand, and click Run.
2. Set the Trigger Delay, if the trigger source is voltage or current, you can set the Trigger Value parameter.

3. For a single trigger, click the Single button and wait for the Trigger Value to be reached.
4. When Time Div is set greater than or equal to 50ms, it enters the scan state and the Scope status indication shows Roll.
5. When the Scope is stopped you can drag the waveform to scale the waveform, at which time the navigation icons will also be scaled isometrically at the same time.

## 3.2 Recorder Mode

### Function Introduction

The data logging function is mainly used to record data such as voltage, current, power, resistance, and calculation during SMU operation, and plot these data into easily observable curves. At the same time, the data can be exported to a USB flash drive by configuring the corresponding parameters.

### Parameters

#### Recorder display parameters

Parameter	Description	Range
Line1/Line2/ Line3	Each curve represents its selected data source, and up to 4 curves can be displayed.	Each curve display box contains the data Meter and the resolution of each cell of the curve.
Line4		Example of voltage represented by a curve: $U = 20V \ 20V/Div$
		$U=20V$ : Present voltage value. $20V/Div$ : Voltage plotting accuracy, check the presented edit box to adjust the parameter by knob.
		Div range: in 1/2/5/10/20/50/100/500 increments, in units depending on the present device gear. Cannot exceed the maximum value of the present data source.
Time	Time display accuracy	Change the parameters in order of 0.01s, 0.02s, 0.05s, 0.1s, 0.2s, 0.5s,

Parameter	Description	Range
		1s, 2s, 5s, 10s, 20s, 50s, 100s, 200s, 500s, 1000s, 2000s
Vernier	Cursor	Used to observe the moment of data appearance

### Recorder setting parameters

Parameter	Description	Range
Run/Stop	Start/Stop Recorder function	Note: Run or stop data logging. When data logging is running, Measure Mode is forced to Continue Measure mode. When you click the Stop function and then Run, the UI will clear the data to redraw the curve.
Clean	Clear recorded data	Clear the present curve and redraw it.
Auto	Automatic adjustment of plot height based on data.	
Hold-On	Hold-On: Pause drawing and hold.	Note: When Hold-On is started, only the graph stops drawing and the data is still running normally. When Hold-Off is clicked again, the data during the pause will continue to be drawn.
	Hold-Off: Continue drawing the graph.	
Curve1/Curve2 /Curve3/Cure4	Curve state selection	Off/On
Item	Curve data source selection	Volts/Amps/Power/Ohms/Source
Mode	Set the display mode of the curve, DC or	<ul style="list-style-type: none"> <li>DC mode: The curve scale is displayed with the 0 value as the center.</li> <li>AC mode: The curve scale takes the lowest value of a waveform as</li> </ul>

Parameter	Description	Range
	AC can be selected.	the scale Base value. The corresponding value of the display scale is Base + Div.
Measure Interval	Measurement Gap  That is, how often the data is measured at intervals.  NPLC /Time	When NPLC is selected, it can be set by NPLC item in plc. <ul style="list-style-type: none"> <li>• 50Hz: 0.005PLC-100.00PLC</li> <li>• 60Hz: 0.006PLC-120.00PLC</li> </ul> When Time is selected, the unit of time is s (100us-2.00s).  <b>Note: Parameters cannot be set after Recorder is run.</b>
Measure Speed	Set measurement data speed  NPLC/ Aperture	When NPLC is selected, it can be set by NPLC item in plc.  When Aperture is selected, the time is measured in seconds.  (0.00001s – Max s)  Note: Max = Measure Interval * 80%  Measure Interval - Measure Speed > 40us  <b>Note: Parameters cannot be set after Recorder is run.</b>
Recorder Mode	Cycle: cycle mode, can cycle sampling  Once: Single sampling	When Cycle is selected, the Point Number setting item is hidden. Default is the maximum number of samples, and the maximum number of samples is 1000000.  When you select Once, you can set the Point Number item.  <b>Note: Parameters cannot be set after Recorder is run.</b>

Parameter	Description	Range
Point Number	Number of sampled data	When recording is started and the number of recorded data is reached, recording will be stopped automatically. Range: (1-1000000) <b>Note: Parameters cannot be set after Recorder is run.</b>
File Format	Save file format: Tdms/Csv	Save file format: IT28XX_recorder_Manual_00XXXX <b>Note: Parameters cannot be set after Recorder is run.</b>
Export To Udisk	Exporting data to a USB flash drive	When the Enter button is pressed, the recorded data is saved to a USB flash drive in Tdms or Csv format.
Save To Udisk Real-time	On: Function on Off: Function off	Save data to USB flash drive in real time. Show when U disk exists, hide this function when U disk does not exist. <b>Note: Parameters cannot be set after Recorder is run. Real-time save U disk function, the number of data can be infinitely long. But the recording speed must be greater than 1ms.</b>

### Export data file format

Model	IT2801					
Sn	XXXXXXXXXXXXXXXXXXXX					
Measure Interval	2.00000s					
Measure Speed	1.60000s					
Time(s)	Volt(V)	Curr(A)	Res (Ohms)	Power (W)	Math (-)	Source(V)

2.31049	1.00E+00	2.63E-08	3.80E+07	2.63E-08	0.00E+00	1.00E+00
4.31048	1.00E+00	2.82E-08	3.54E+07	2.82E-08	0.00E+00	1.00E+00
6.31048	1.00E+00	3.30E-08	3.03E+07	3.30E-08	0.00E+00	1.00E+00
8.31048	1.00E+00	3.30E-08	3.03E+07	3.30E-08	0.00E+00	1.00E+00
10.3104-8	1.00E+00	2.97E-08	3.37E+07	2.97E-08	0.00E+00	1.00E+00
12.3104-8	1.00E+00	2.16E-08	4.64E+07	2.16E-08	0.00E+00	1.00E+00
14.3104-8	1.00E+00	2.53E-08	3.95E+07	2.53E-08	0.00E+00	1.00E+00
16.3104-8	1.00E+00	2.67E-08	3.75E+07	2.67E-08	0.00E+00	1.00E+00
18.3104-8	1.00E+00	2.48E-08	4.03E+07	2.48E-08	0.00E+00	1.00E+00
20.3104-8	1.00E+00	2.87E-08	3.48E+07	2.87E-08	0.00E+00	1.00E+00
22.3104-8	1.00E+00	2.80E-08	3.57E+07	2.80E-08	0.00E+00	1.00E+00
24.3104-8	1.00E+00	2.76E-08	3.62E+07	2.76E-08	0.00E+00	1.00E+00
26.3104-8	1.00E+00	2.92E-08	3.43E+07	2.92E-08	0.00E+00	1.00E+00
28.3104-8	1.00E+00	3.02E-08	3.31E+07	3.02E-08	0.00E+00	1.00E+00
30.3104-8	1.00E+00	3.01E-08	3.32E+07	3.01E-08	0.00E+00	1.00E+00
32.3104-8	1.00E+00	2.57E-08	3.89E+07	2.57E-08	0.00E+00	1.00E+00
...	...	...	...	...	...	...

Note:

1. After the recorder function is running, the manual trigger function in Normal mode cannot be used, and the continuous trigger function under Normal is timed to trigger the Measure interval time under Recorder.
2. The Measure Speed time under Configure screen is invalid. The measurement time is the Measure Speed under Recorder.
3. Recorder function off, restore the configuration parameters under Config.

## Interface operation introduction

Viewing settings screen:

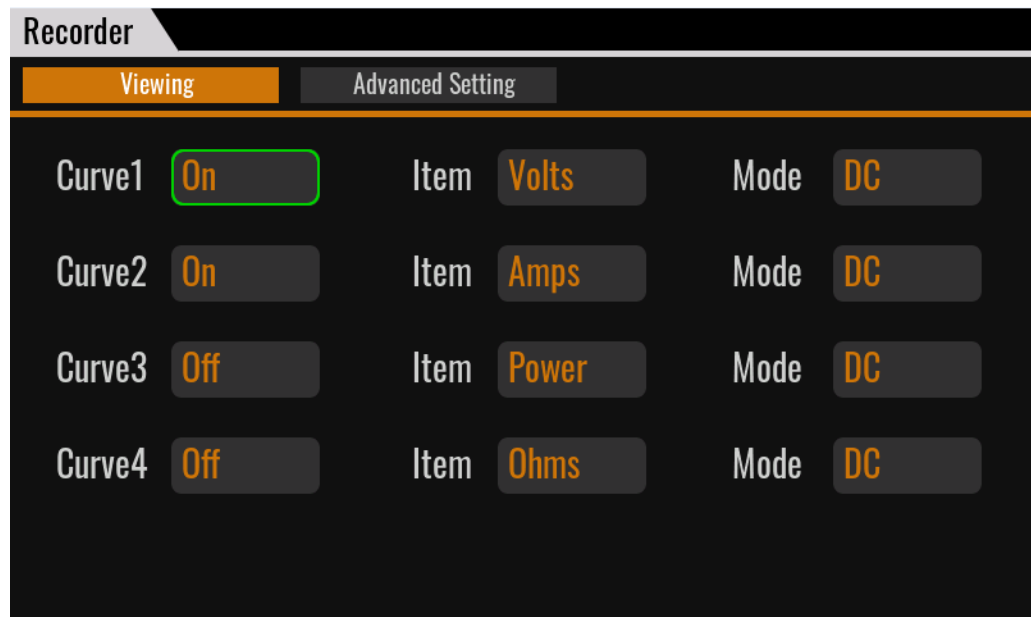

- Set Curve1/Curve2/Curve3/Curve4 ON/OFF status.
- Set the corresponding curve data source.

Advanced Setting interface:

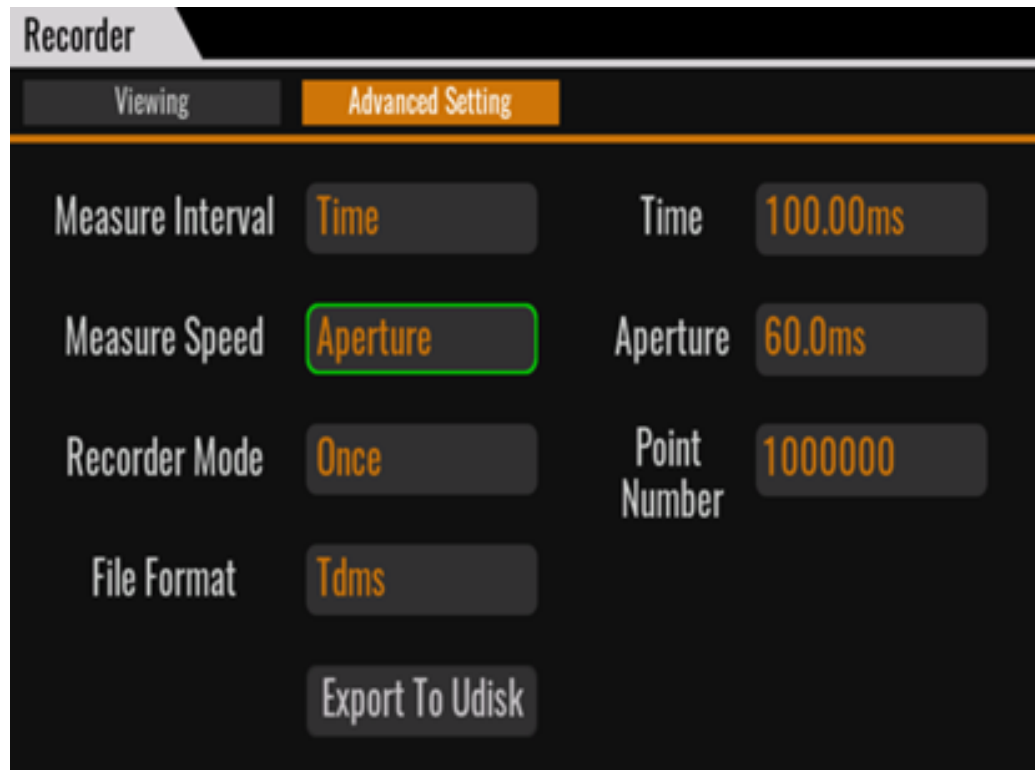

- Sets the Measure Interval type and the sample interval specific parameters.
- Set the Measure Speed parameter type and the sample speed specific parameters.
- Set the operation mode, set to Cycle, and the default Point Number is the maximum value. To set the mode to Once, you need to set the Point Number, and refer to the related parameter item for the Point Number setting.
- Set the file storage format, and the Save To Udisk Real-Time item to select the real-time storage status.
- When Recorder is running, you can export the data via the Export to Udisk.

**Recorder main interface operation:**



1. Click Run to run the data logging function, the current tab will show Stop, click Stop again will stop running, at this time the tab will show Run, wait for running again.
2. Adjust the parameter display accuracy adjustment, such as voltage, current, power, resistance and other parameters, as in the figure,  $I=24.04\text{nA}$  is the current measurement value,  $100.0\text{nA/Div}$  indicates the size of each frame. When the measured value increases and exceeds the range that can be displayed on the front panel, press Auto at this time, the size of each cell will be automatically adjusted according to the maximum value of the displayed parameters to ensure that the waveform of the data can be completely displayed on the interface.
3. Adjust the time display accuracy Time to increase or decrease the display accuracy to fit the overall waveform display.
4. When you want to observe the data at a certain moment, you can choose the Hold-On function to pause the graph drawing, and use the cursor function to view the data corresponding to the moment. During the Hold-On process, the data will not be lost, and after clicking Hold-Off, the data will be drawn to the latest moment.
5. Click Clean to clear the waveform and plot the curve based on the latest moment data.

## 3.3 Measure Limit

### Function Introduction

The limit test is a PASS/FAIL judgment by the obtained measurement data or mathematical calculation results, and up to 12 limit tests can be set. Each limit test item can be individually configured with IO output to indicate the test status, and provide a test result viewing interface to analyze the test results through the data records and graphs.

The tests are divided into two types: graded mode, which is designed to test up to 12 limits until they fail, and sequenced mode, which is designed to test up to 12 limits until they pass.

## Parameters

Parameter	Description	Range
Mode	Limit test mode.	Grading Sorting
	Grading: Grading mode	
	Sorting: Sorting mode	
Feed Data	Type of measurement data for limit value comparison	MATH VOLT CURR OHMS
	MATH: Mathematical formulas	
	VOLT: Measured voltage value	
	CURR: Measured current value	
	OHMS: Measured resistance value	
Start of test	Trigger source selection for start-up	IO-SOT Manual Bus
Limits	Number of limit test comparisons	1-12
Components	Number of test data	0-50000
Repeat Num	Number of repetitions	2-1000
Auto Clear	Auto-clear function	ON OFF
Update	For Grading mode only, set whether to output the result immediately or after it is finished.	IMMEDIATE END
EOT Delay	Test stop delay	30us-60s

Parameter	Description	Range
All pass pattern/All Fail Pattern	Bits of Pass status in graded mode, or Fail status in sorted mode	0-4095
Type	Test type	Limit Compliance
Fail On	Can be set when selecting compliance testing	IN OUT
High limit	The upper limit of the limit value test	Min-Max
Low limit	The lower limit of the limit value test	Min-Max
Pass pattern	Limit test Pass bit	0-4095
Fail Pattern	Limit test Fail bit	0-4095

**Flow chart of the grading model:**

### Grading mode limit testing

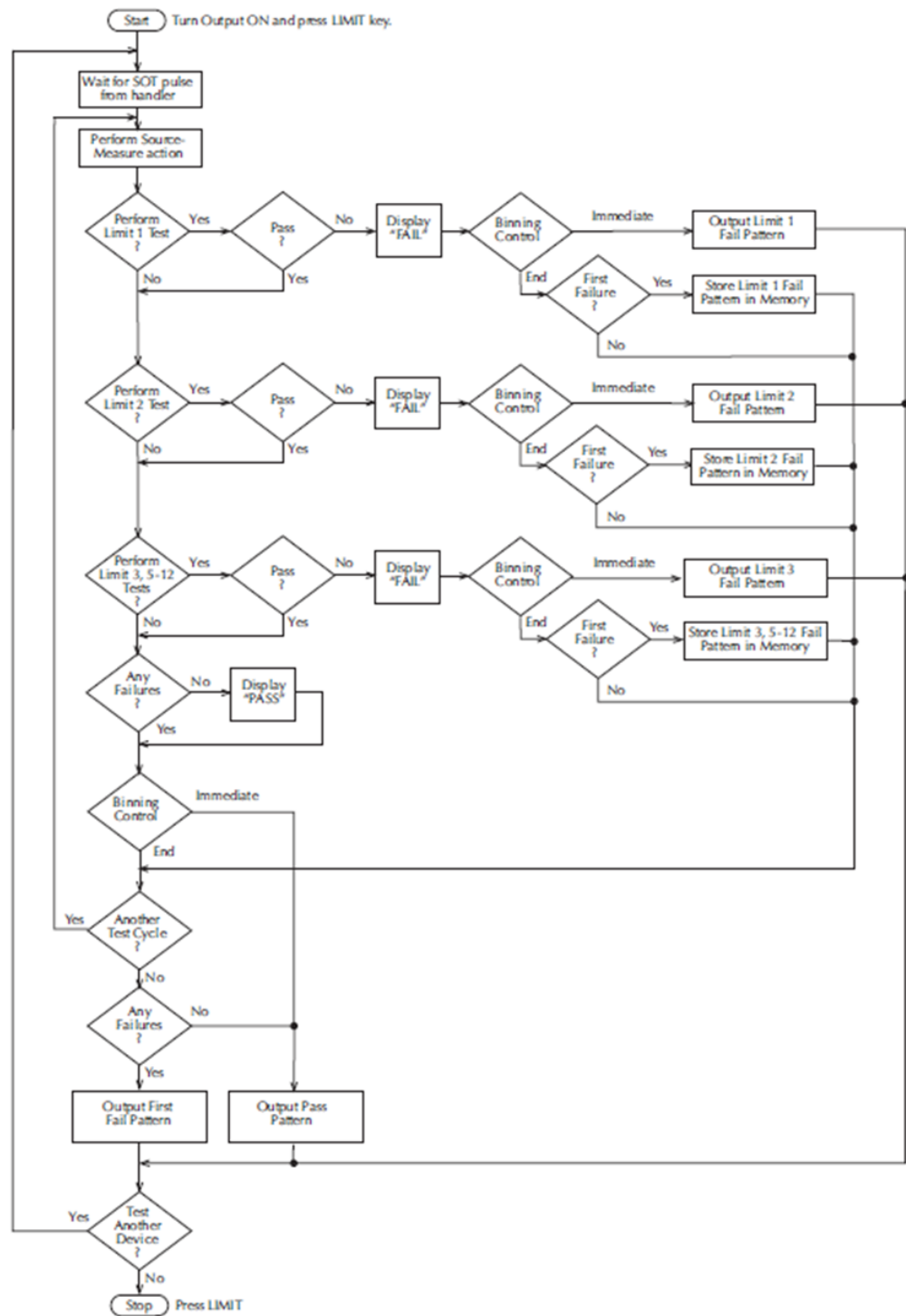

Flow chart of the sorting model:

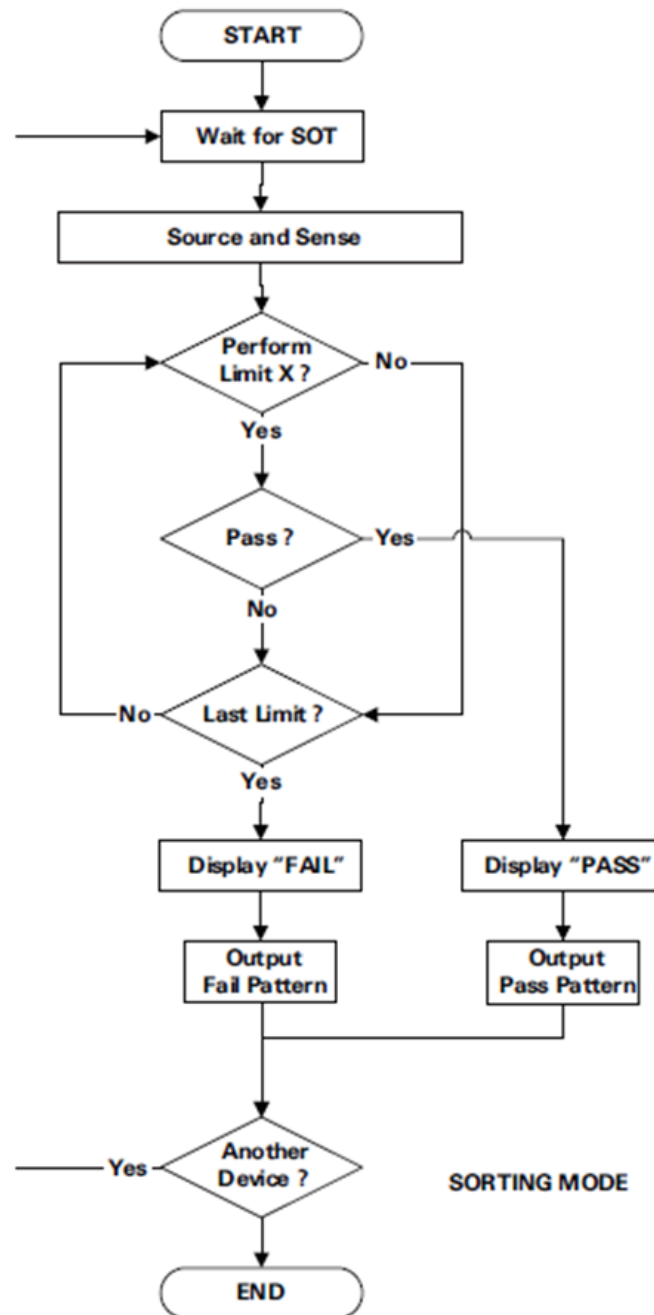

### Mode Selection

Mode selection Grading for grading mode, limit test is executed for up to 12 test limits until failure is detected; mode selection Sorting for sorting mode, limit test is executed for up to 12 test limits until pass is detected.

### Data sources for limit value testing

When the data source is set to RESIST mode, the data source resistance for the limit test is calculated from the voltage measurement value/current measurement value and the RTD compensation mode can be turned on. When

set to MATH mode, the data source is given by the result of the mathematical expressions calculated by the Math function of the device.

### **Trigger source for limit tests**

The trigger source is selected as DIG IO, and the /EOT pin of GPIO receives the rising edge to initiate the limit test, set to Manual to initiate the limit test through the **[Trig]** key on the panel, and set BUS to initiate the limit test by sending **\*TRG** command.

### **Number of test limits**

Test limits can be set to a maximum of 12, only Limit1 can be set to Compliance mode. Compliance prevents damage to the test equipment caused by overvoltage or overcurrent. Voltage compliance is used for current mode, the measured voltage value between +Compliance and -Compliance to meet compliance detection. Current compliance is used for voltage mode. The compliance test is satisfied when the measured current value is between +- Compliance and -Compliance. The Fail On parameter can be configured during compliance testing. When the device is in compliance, setting IN will determine that the limit test fails and setting OUT will determine that it succeeds; if the device is not in compliance, setting IN will determine that the limit test succeeds and setting OUT will determine that it fails.

In addition to Limit1, other Limits can only be set to Limit mode. When set to Limit mode, if the test data is between High Limit and Low Limit, it will determine success, otherwise it will fail. The IO port of High Pattern setting is valid when the test data is greater than High Limit value, and the IO port of Low Pattern setting is valid when it is less than Low Limit value.

### **Number of test data**

The limit test stops when the number of limit tests reaches the number of test data set. To perform the limit test again, you need to turn on the limit test again. When the number of test data is set to 0, the limit test is executed an unlimited number of times.

### **External Interface**

The system provides 12 configurable IO ports that can be configured by the user via Pattern to indicate the limit test Pass/Fail status.

The SOT pin is used to initiate the limit test when the user configures the trigger source to be DIG IO.

The BUSY pin is used to indicate whether the limit test is busy or not.

The EOT pin is used to indicate whether the limit test is finished.

The OE pin is used to indicate whether the SMU output is on or not.

### Timing of automatic clearance

When setting Auto Clear to On, you can set the time to end the delay. As shown in the figure below, all IO ports are high before the test starts, and the limit test starts when a low pulse from SOT is received. The /BUSY signal is pulled low during the test. After the limit test ends, the corresponding IO port is pulled low according to the Pattern parameter of the limit test configuration, which is used to indicate the status of the test Pass/Fail. Delay 10us to start the test and end the delay, the time can be set to 0-60s. After the delay time ends, the EOT signal returns to high level, and all signals and all IO port signals return to high level after 10us. If auto clear is set to Off, each IO port keeps the state of test end after test end, /EOT pulls low, /BUSY pulls high immediately after test end, and EOT signal pulls high at the start of next test.

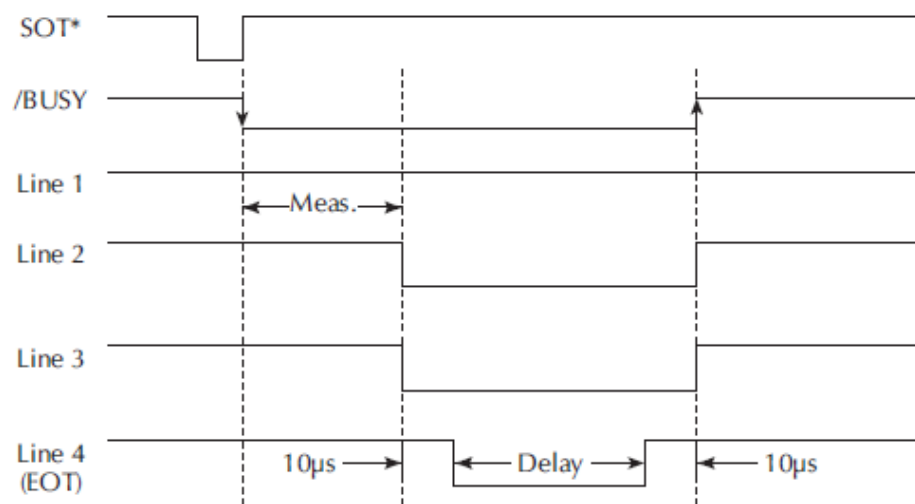

### Grading mode output result timing setting

The Limit Test is set to the Graded Mode to set the Update parameter. When set to Immediate, once a Fail occurs during the test, the corresponding level is immediately output through the IO configured by the Fail Pattern, and the test ends immediately. When set to END, the test results are not output immediately, waiting for the number of tests that have been set to be completed, then output the results.

### Saving and exporting test results

Test results can be viewed through the Limit Test View screen when the test is complete. The test results are displayed in the format:

Serial Number + Time + Data + Status

Serial number: Serial number of the limit test, index of the data

Time: The relative time of the test

DATA: Data records of limit tests performed

PASS/FAIL: Test results

### Test Histogram Interface

The histogram interface is used to view the percentage of limit tests passed and failed. It reflects the ratio of the number of test Pass/Fail to the total number of tests.

### Saving data

The device can save the test data in the U disk. Specific format: Serial number + Time + Data + Status, and can support to U disk real-time recording of limit value test data.

### Limit parameter saving and recalling

The SMU provides 10 groups of storage space for saving limit test configuration parameters, which can be freely saved and recalled by the user. And the present setting parameters support power-down saving.

## 3.4 Battery Simulation

### Function Introduction

The function of battery simulation is to simulate the actual battery output state as well as the charging and discharging characteristics of the battery, which can be achieved by setting the relevant properties of the battery to simulate the reaction of the battery under different conditions according to the user's requirements. For example, full state voltage value, empty state voltage value, internal resistance, maximum capacity of the battery, the number of simulated battery connected in parallel and series, positive and negative limit current values of the battery packs, etc.

### Parameters

The IT2800 series battery simulation modes are divided into two modes: User define and Curve, and the corresponding running files can be edited in different modes.

#### Generalized parameters:

Parameter	Description	Range
Initial Value	Initial battery capacity ratio	0%-100%
SOC Upper	Upper limit of charging capacity	100%-110%

Parameter	Description	Range
SOC Lower	Lower limit of discharging capacity	-10%-0%
End Type	Hold: Holds the capacity when charging to the upper capacity limit value or discharging to the lower capacity limit value.  Off: Turns off the output when charging to the upper capacity limit or discharging to the lower capacity limit.	Hold/Off

SOC (State of charge), i.e. the state of load, is used to reflect the remaining capacity of the battery, which is numerically defined as the ratio of the remaining capacity to the total capacity of the battery, and is often expressed as a percentage. Its value range is 0~1.

VOC (open-circuit voltage), indicates the battery open-circuit voltage.

**User define mode parameter:**

Parameter	Description	Range
Cell Full Voltage	Full voltage of a single cell	0V- Full Voltage Max  Full Voltage range determination step: 1. Determine the current range according to the I-Limit+ parameter.  2. Determine the voltage range corresponding to the current range according to the specifications of the model, and find the Max/Min value of the voltage range.  3. Determine the number of Serial Number of the battery.  Full Voltage Max = Max/Serial Number Full Voltage Min = 0V
Cell Empty Voltage	Empty voltage of a single cell	0V- Empty Voltage Max

Parameter	Description	Range
		Empty Voltage range determination step: 1. Determine the current range according to the I-Limit+ parameter. 2. Determine the voltage range corresponding to the current range according to the specifications of the model, and find the Max/Min value of the voltage range. 3. Determine the number of Serial Number of the battery. Empty Voltage Max=Max/Serial Number Empty Voltage Min = 0V;
Cell Inner Resistance	Inner resistance of a single cell	0-10Ω
Cell Capacity	Capacity of a single cell	0-999.999Ah
Parallel Number	Number of single cells in parallel	1-99
Serial Number	Number of single cells in series	1- Serial Number Max Serial Number range determination step: 1. Determine the Full Voltage maximum value Voltage Max. 2. Determine the Full Voltage parameter. Serial Number Max = Voltage Max/Full Voltage Serial Number Max less than or equal to 99 Serial Number Min = 1

Parameter	Description	Range
I-Limit+	Output current upper limit value when simulating batteries	0A- Current Max I-Limit+ range determination step: 1. Determine the voltage range according to the Full Voltage parameter. 2. According to the specifications of the model to determine the current range corresponding to the voltage range, to find the maximum value of the current range Current Max. 3. I-Limit Max = Current Max I-Limit Min = 0A
I-Limit-	Upper limit of sink current when simulating batteries	Current Min-0A I-Limit- range determination step: 1. Determine the voltage range according to the Full Voltage parameter. 2. According to the specifications of the model to determine the current range corresponding to the voltage range, to find the minimum value of the current range Current Min. 3. I-Limit Max = 0A I-Limit Min = Current Min

**Battery simulation file format in User define mode :**

Model	IT2801
File Type	Battery emulator
Sub Type	User define
Cell Full Voltage	21.000V
Cell Empty Voltage	0V
Cell Inner Resistance	5.000000mΩ

Cell Capacity	10Ah
Parallel	1
Serial	1
I-Limit +	1.000A
I-Limit -	-1.000A

### Curve mode parameter:

#### 1. Curve Edit parameters

Parameter	Description	Range
Cell SOC	Cell battery remaining capacity ratio	0%-100%
Cell Voltage	Present voltage of the cell battery	0V – Voltage Max Cell Voltage Range Confirmation Procedure: 1. Confirm the current range of the model according to I-Limit+. 2. Determine the maximum value of voltage Max for the corresponding current range according to the specifications of the model. 3. Determine the number of cells in series Serial Number. $\text{Voltage Max} = \text{Max/Serial Number}$
Cell Res	Present resistance of the cell battery	0-10Ω



#### Note

Note: Cell SOC, Cell Voltage parameter settings need to maintain the monotonicity of the parameter to ensure that the curve monotonically increasing or decreasing.

#### 2. Common Edit parameters

Parameter	Description	Range
Cell Capacity	Capacity of single cell	0-999.999Ah
Parallel Number	Number of single cells in parallel	1-99
Serial Number	Number of single cells in series	1-Max Max parameter confirmation step: 1. Determine the maximum value of voltage range (Voltage Max) corresponding to the current range according to the I-Limit+ parameter. 2. Determine the maximum voltage Voltage from the Curve file. Max = Voltage Max/Voltage Max less than or equal to 99
I-Limit+	Upper limit value of the limiting current	0A- Current Max I-Limit + range determination step: 1. Find the maximum voltage Voltage based on the Curve file to determine the voltage range. 2. Determine the current range corresponding to the voltage range according to the specifications of the model, and find the current maximum value Current Max of this range. 3. I-Limit Max = Current Max I-Limit Min = 0A
I-Limit-	Lower limit value of limiting current	Current Min-0A I-Limit- range determination step:

Parameter	Description	Range
		1. Find the maximum voltage Voltage based on the Curve file to determine the voltage range.  2. Determine the current range corresponding to the voltage range according to the specifications of the model, and find the current minimum value Current Min of this range.  3. I-Limit Max = 0A  I-Limit Min = Current Min

**Battery simulation file format in Curve mode:**

Model	IT2801	
File Type	Battery emulator	
Sub Type	Curve	
Parallel	1	
Serial	1	
I-Limit +	1.000A	
I-Limit -	-1.000A	
Cell Capacity	10.000Ah	
Cell SOC	Cell Voltage	Cell Res
10%	12.2	0.01
10.10%	13.2	0.01
11.10%	14.2	0.01
12.10%	15.2	0.01
13.10%	16.2	0.01
14.10%	17.2	0.01
15.10%	18.2	0.01
100%	19.2	0.01

## Introduction of interface operation

## User define mode

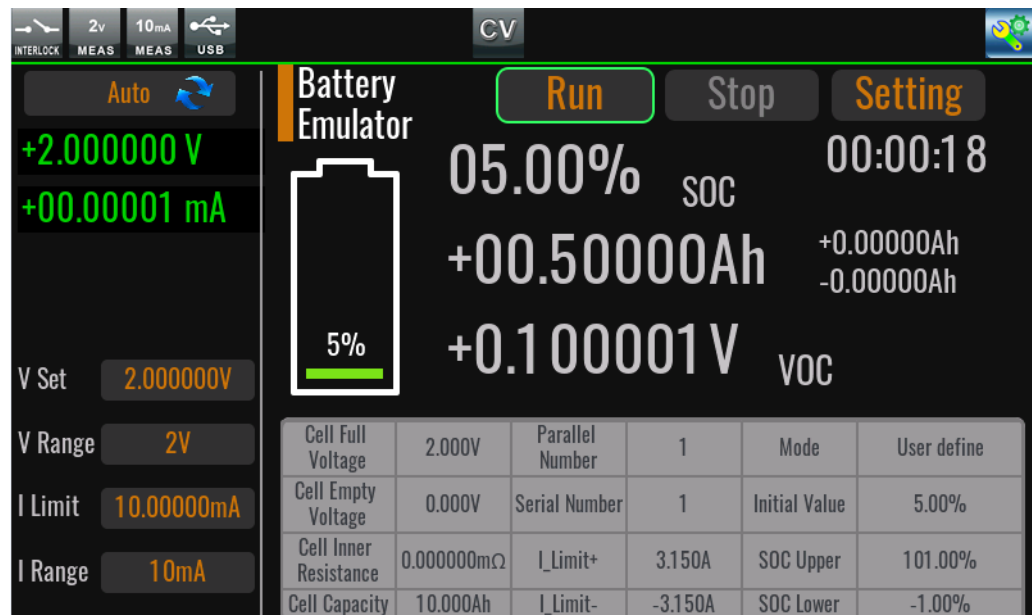

- During the test run, the meter is displayed and the ranges and parameters cannot be set.
- Click Run to start the battery simulation function, click Stop to stop the test, click Setting to configure the parameters, all the parameter configuration items will be displayed at the bottom of the main interface.
- SOC: Indicates the remaining capacity ratio of the battery, while the battery icon shows the present status in real time, the green part is the remaining capacity, the lightning icon indicates that the battery is charging, and the lack of the lightning icon indicates that the battery is in idle or discharged state.
- AH: Present capacity of the battery, for display only. The display accuracy will change according to the current range.
- VOC: Open circuit voltage of the battery. Display accuracy varies according to the voltage range.
- 00:00:00 is the battery run time, refreshed and cleared when the **Run** button is clicked.
- +0.50000AH and -0.00000AH: Capacity increase and decrease during battery simulation.

### Battery Setting

Battery-01.csv
New File
Save
Save As
Delete File

Parameter	Value		
Cell Full Voltage	2.000V	Mode	User define
Cell Empty Voltage	0.000V	Initial Value	5.00%
Cell Inner Resistance	0.000000mΩ	SOC Upper	101.00%
Cell Capacity	10.000Ah	SOC Lower	-1.00%
Parallel Number	1	End type	Hold
Serial Number	1		
I_Limit+	3.150A		
I_Limit-	-3.150A		

- Click **Open File** to select the battery simulation file for User define mode stored within this instrument. Once the file is selected, the **Open File** label changes to the selected file name.
- Clicking **New File** will clear the data in the list and the selected file will be out of selection for new file editing.
- Click **Save** or **Save As** to save the edited file and name it. (Note: Battery Emulator has standardized naming rules. In User Define mode, it is recommended to name the file in **Batthey-XXX.CSV** format.)
- Click **Delete File** to delete the selected file.
- Cell Full Voltage, Cell Empty Voltage and other parameters can be set through the software interface according to the range in the parameter introduction.

#### Procedure:

1. Select mode as User Define.
2. Click New File or Open File to enter the editing state.
3. After configuring Full voltage, empty voltage, Inner resist, capacity, Parallel number, Serial number, I-Limit +, I-Limit - parameters, Save the file and press esc to return.
4. Configure Initial Value as 0-100%, SOC Upper, SOC Lower, End Type.
5. After pressing the Run button, the battery simulation starts to run and both SOC and AH change in real time.

#### Curve Mode

1. Introduction of the main interface.

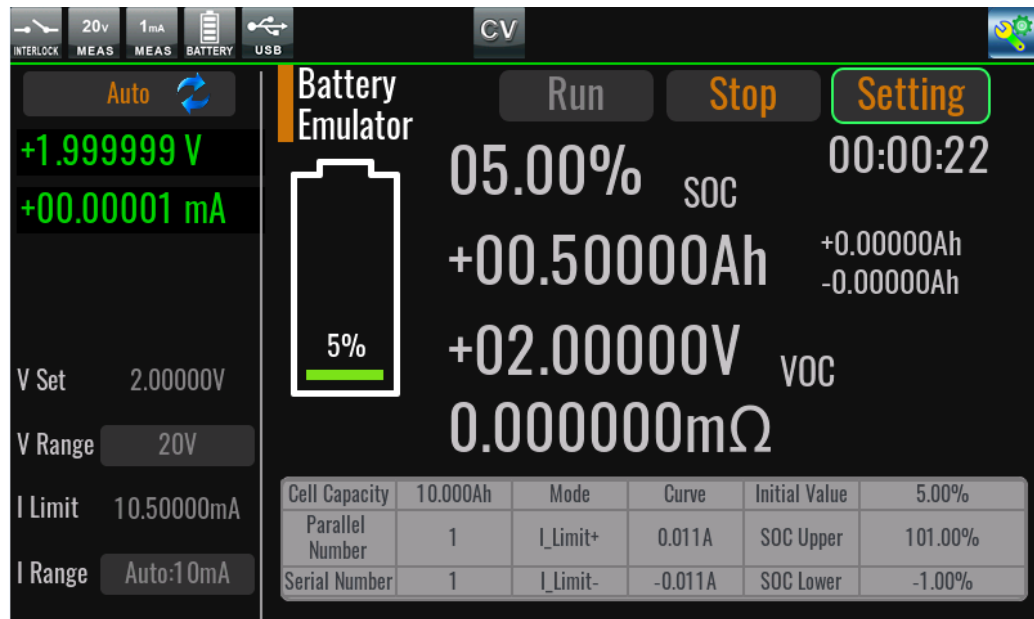

- Click Run to start the battery simulation function, click Stop to stop the test, click Setting to configure the parameters, the contents of the Common Edit parameters in the Curve file are displayed at the bottom of the main interface, and the specific contents of the parameters are referred to the introduction of Curve parameters.
- SOC: Indicates the remaining capacity ratio of the battery, while the battery icon shows the present status in real time, the green part is the remaining capacity, the lightning icon indicates that the battery is charging, and the lack of the lightning icon indicates that the battery is in idle or discharged state.
- AH: Present capacity of the battery, for display only. The display accuracy will change according to the current range.
- VOC: Open circuit voltage of the battery. Display accuracy varies according to the voltage range.
- 00:00:00 is the battery run time, refreshed and cleared when the **Run** button is clicked.
- +0.50000AH and -0.00000AH: Capacity increase and decrease during battery simulation.
- 0.0005mΩ : Present battery internal resistance.

## 2. Introduction of the setup interface.

**Battery Setting**

Open File
New File
Edit File
Delete File

Cell Capacity	10.000Ah
Parallel Number	1
Serial Number	1
I_Limit +	0.011A
I_Limit -	-0.011A

No	Cell SOC	Cell Voltage	Cell Res

Mode Curve  
 Initial Value 5.00%  
 SOC Upper 101.00%  
 SOC Lower -1.00%  
 End type Hold

- Click **Open File** to select an existing Curve mode file locally or on a USB flash drive, and the **Open File** tab will change to the name of the selected file.
- Click **New File** to enter the Curve file editing interface.
- Click **Edit File** to edit an open file. If you do not have an open file, clicking this item will not work.
- Click **Delete File** to delete the selected file.
- The edited parameters can be displayed in the list below.

### 3. Introduction of the Curve edit interface.

**Battery edit**

Description:null

Curve edit
Common edit

No	Cell SOC	Cell Voltage	Cell Res
1			

Save
Save As
Clear All
Esc

- Click Cell SOC, Cell Voltage, Cell Res to configure their parameters via soft keyboard.

- After editing a set of parameters, the **NO.** parameter will change to **1...**, at this time, click **1...** can choose to Inset or Delete the parameters for the line.
- Click **Save** or **Save As** to save the present file and name it. (Note: Battery Emulator has a naming standard, Curve mode is recommended to be named in **Bat-Cur-XXX.CSV** format.)
- Clicking **Clear All** will clear all edited content.
- Clicking **Esc** will exit the editing interface without saving the parameters to file.

#### 4. Introduction of Common Edit Interface

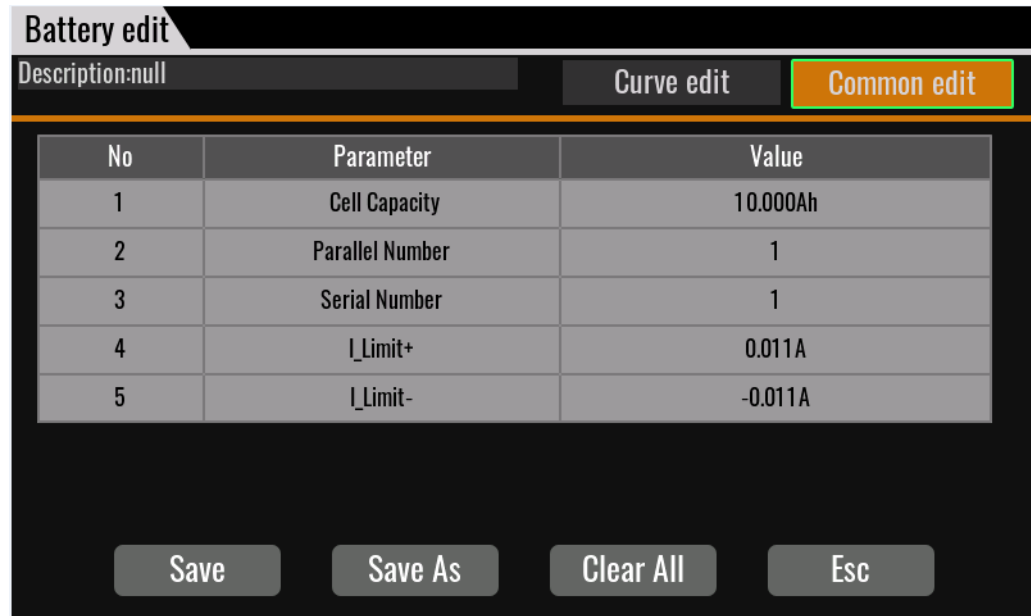

No	Parameter	Value
1	Cell Capacity	10.000Ah
2	Parallel Number	1
3	Serial Number	1
4	I_Limit+	0.011A
5	I_Limit-	-0.011A

- Click Cell Capacity, Parallel Number, Serial Number, I-Limit+, I-Limit- to set parameters via soft keyboard.
- Click **Save** or **Save As** to save the present file and name it. (Note: Battery Emulator has a naming standard, Curve mode is recommended to be named in **Bat-Cur-XXX.CSV** format.)
- Clicking **Clear All** will clear all edited content.
- Clicking **Esc** will exit the editing interface without saving the parameters to file.

#### Procedure for Curve mode:

1. Select mode as **Curve**.
2. Insert the USB flash drive and click **Open File**.
3. Select the Curve file to be run.
4. Configure the Initial Value (0-100%).
5. After pressing the Run button, the battery simulation starts running. Both SOC and AH will change in real time.

## 3.5 Synchronous On/Off Function

### Function Introduction

The synchronization on/off function is used for multiple IT2800 fiber parallel scenarios. When the synchronization function is enabled and the following conditions are met, multiple IT2800 SMUs can perform synchronization on/off operations.

- Synchronizes the source-output operation (transient operation).
- The fiber optic cable is connected correctly.
- Configure one SMU as Master.
- Configure all other SMUs as slaves.
- Turn on the **Output On Sync** function.
- Turn on the **Output Off Sync** function.
- Select the same grouping A or B or C or D.

### Parameters

Parameter	Description	Range
Role	Setting the present role	Single: Single mode
		Master: Master mode
		Slave: Slave mode
Group	Setting the group number (available only in Master or Slave mode)	A: Group A
		B: Group B
		C: Group C
		D: Group D
Output On Sync	Synchronized output on function (configurable only in Master or Slave mode)	Off: Turn off the Output On synchronization
		On: Turn on the Output On synchronization

Parameter	Description	Range
Output Off Sync	Synchronized output off function (configurable only in Master or Slave mode)	Off: Turn off the Output Off synchronization
		On: Turn on the Output Off synchronization
Numbers	Display the number of parallel devices (visible only in Master mode)	Displays the number of fiber-optic parallel devices, and if the connection fails or is in the unconnected state, it displays Networking...

## Introduction of interface operation

### On/Off synchronization setting interface:

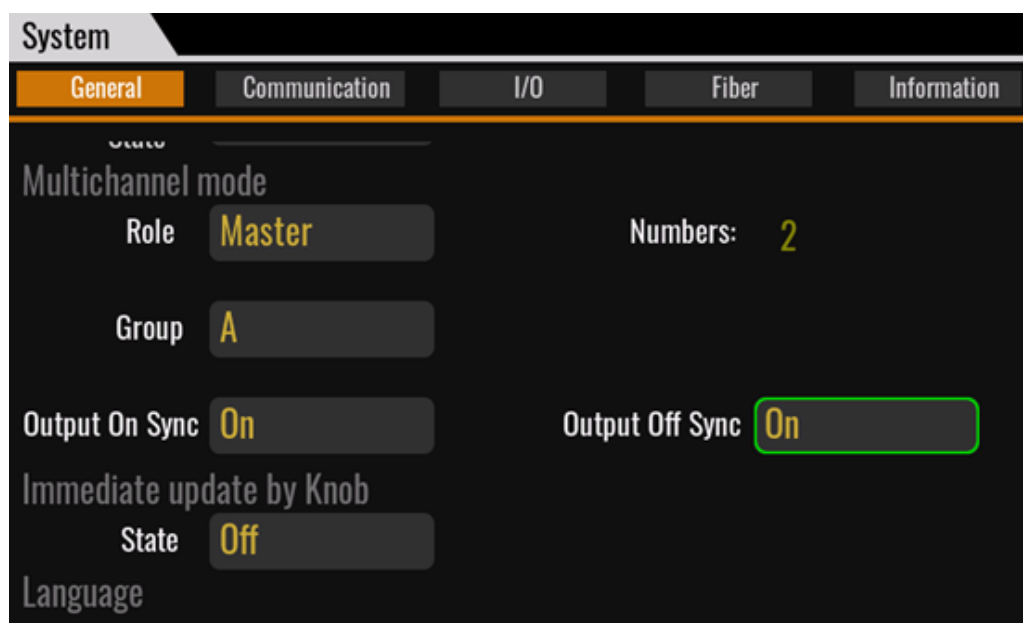

In addition to setting up Master/Slave, you also need to set up A/B/C/D grouping and it is not possible to synchronize On/Off between different groupings.

#### CAUTION

**If you do not have the correct configuration, or if the fiber optic cable is not connected, the Master's Numbers will always be displayed in the unconnected state, as shown in the following figure.**

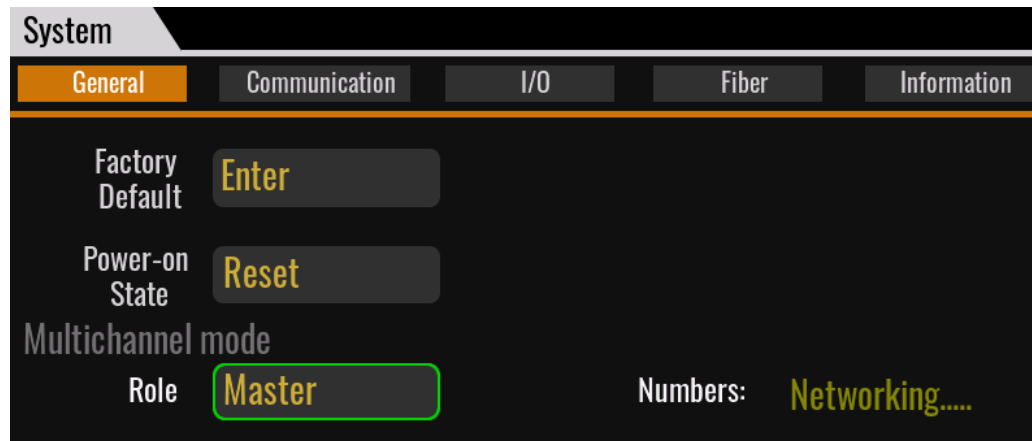

## 3.6 Protection Functions in Detail

### Overvoltage / overcurrent protection

The overvoltage/overcurrent protection feature effectively prevents damage to the test equipment due to overcurrent or overvoltage. If this feature is enabled, the SMU will immediately and automatically turn off the output when it reaches a compliance state.

Set the over voltage / over current protection, configure it to **On** via **config->source->output connection->Over V/I protect**.

- When mode is voltage source, then the current is the protection value or limit value, if **Over V/I protect** is turned on, the output will be turned off when the current output reaches the I Limit setting; if **Over V/I protect** is turned off and the current output reaches the I Limit, then the current will be maintained at the I Limit value output all the time.
- When mode is current source, then the voltage is the protection value or limit value, if Over V/I protect is turned on, the output will be turned off when the voltage output reaches the V Limit setting; if Over V/I protect is turned off and the voltage output reaches the V Limit, then the voltage will be maintained at the V Limit value output.

### Interlocking function

The interlock function is designed to prevent the user from being electrocuted when touching the measurement terminals. If the interlock terminals are open, the maximum output is limited to  $\pm 42$  V. To perform high voltage measurements above  $\pm 42$  V, the interlock terminals must be shorted.

The interlock function works as described below.

- When the interlock terminals are open, the maximum output is limited to  $\pm 42$  V. If the SMU detects a voltage output higher than 42 V, the SMU

immediately turns off the output and generates an alarm. Display icon:



Pressing the **esc** key removes the alarm.

- When the interlock terminals are shorted, the source channel can apply its maximum output value.
- When the interlock terminals are disconnected under high voltage conditions exceeding  $\pm 42$  V, the output is immediately OFF and an alarm is generated.



Icons are displayed:

Pressing the **esc** key removes the alarm.

### Over temperature protection

When the internal temperature of the SMU exceeds  $55^{\circ}\text{C}$ , the SMU automatically turns off the output for protection. An alarm is also generated and

an icon is displayed: 

Pressing the **esc** key removes the alarm. Wait for the temperature to decrease before turning the output back on.

### Multi-machine failure alarm

During the use of multi-machine interconnection, if a synchronization configuration error or fiber optic communication abnormality occurs, an icon will

appear on the Meter interface: 

Until wired or configured correctly, or returned to single-unit mode, this alarm will automatically be eliminated.

## 3.7 Sweep Function

### Function Introduction

Sweep mode supports scanning output of multiple waveforms, as shown in the figure below. Not only does it perform sweep output, but it also performs measurements for each step.

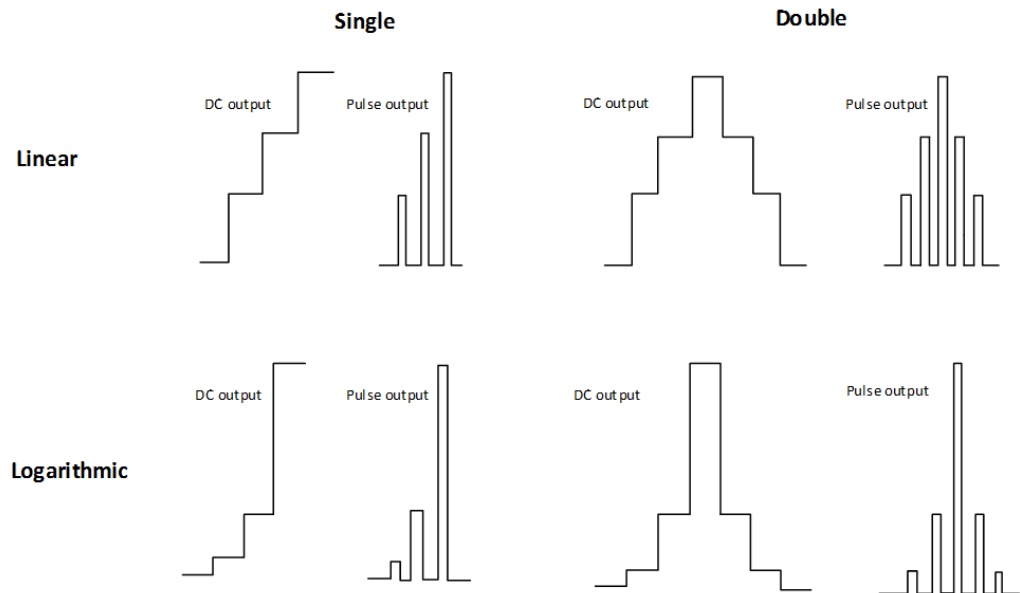

## Interface Introduction



- **Run/Stop** can be used to start or stop the sweep function.
- **I-U** Display the menu, which can be used to switch the curve display mode, has the following display modes.
  - I-U: The x-axis represents voltage and the y-axis represents current.
  - U-I: The x-axis represents current and the y-axis represents voltage.
  - Datalist: Displays the measurement data in a list.
- **Auto**: Automatically adjusts the x/y-axis display boundaries according to the collected data so that the data can be fully displayed in the data frame.
- **Clear**: Clear the curves in the display box.
- **Setting**: The configuration menu.

A description of the specific interface parameters is given later.

- **Measure:** Characteristic parameter display switch, when turned on, it can display the maximum value of voltage, maximum value of current, maximum value of power of the latest curve and the value of voltage and current at this time.
- **Cursor:** Cursor line. When turned on, there is a red cursor line. This displays the focus value of the red cursor line when it intersects the latest line.
- **Step:0V** Indicates the present output step value after the sweep run.

## Setting Menu Details

### Common Setting

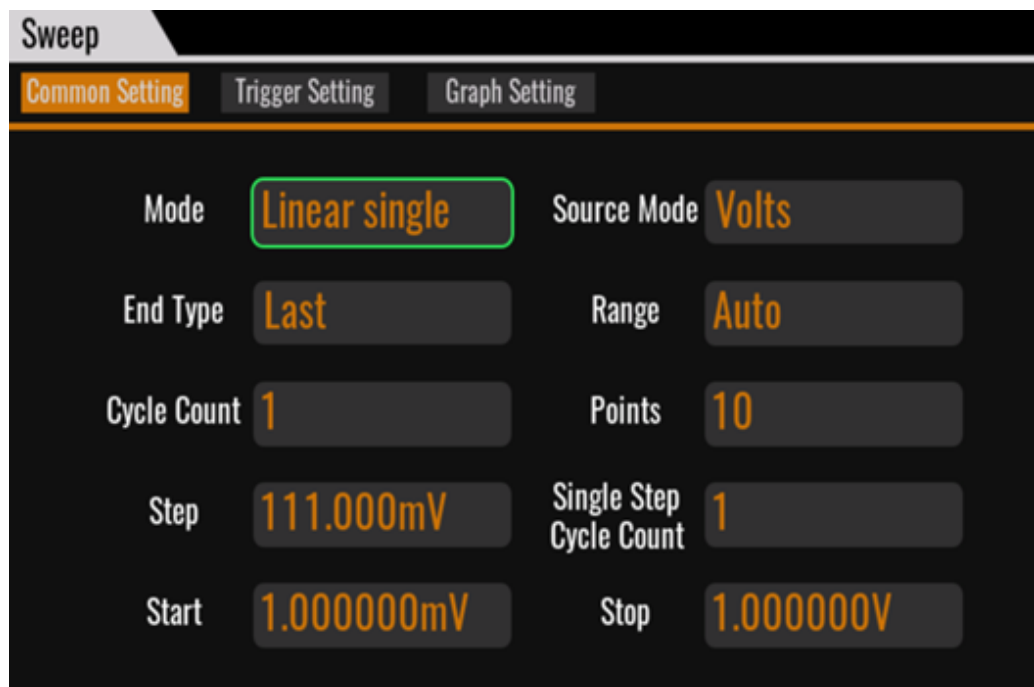

The IT2800 supports the following scanning **Mode**.

- Linear single: Scans from the start to the end in linear incremental steps.
- Linear double: Scans from the start to the end and back to the start in linear incremental steps.
- Log single: Scans from the start to the end in logarithmic incremental steps.
- Log double: Scans from the start to the end and back in logarithmic incremental steps.
- List: Scans the values defined in the setup list.

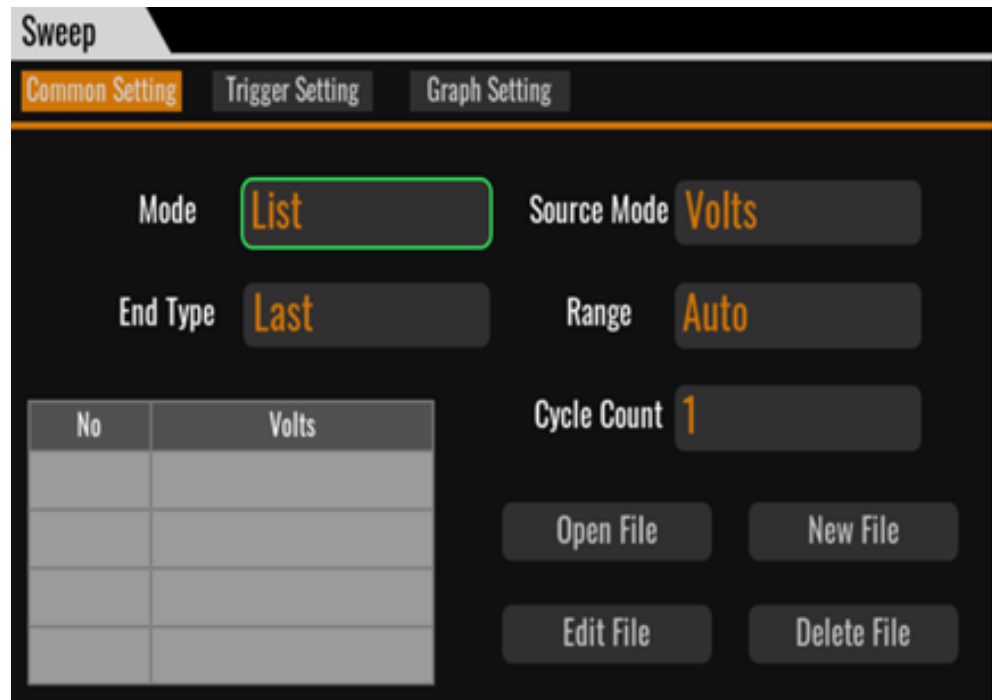

- **Open File:** Open a list file that already exists inside the instrument or is saved on a USB flash drive.
- **New File:** Create a new list file.

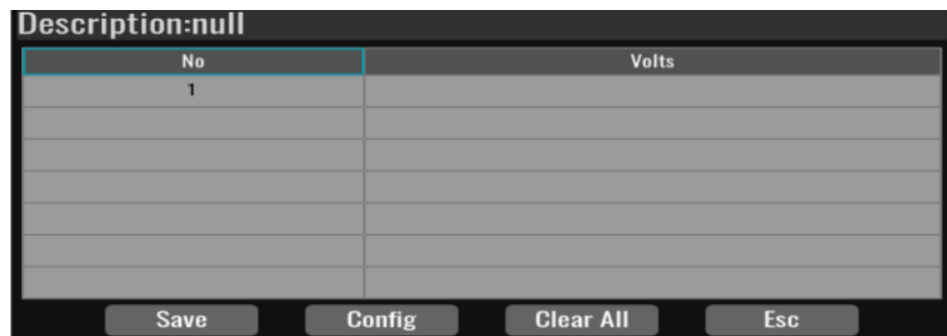

- **Edit File:** Edit an opened or newly created list file.

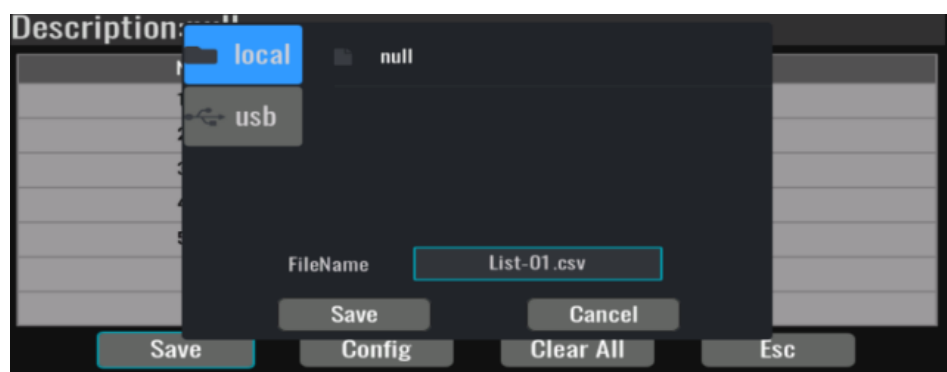

- ◆ **Save:** Save the edited list file to the instrument or to a USB flash drive and make the setting data effective.
- ◆ **Config:** Make the edited data effective.

- ◆ **ClearAll:** Clear the edit list.
- ◆ **Esc:** Return to the list main menu.
- **Delete File:** Delete the list file that already exists inside the instrument or is saved on a USB flash drive.

Other parameters of the **Common Setting** interface are described below:

Parameter	Description
Source Mode	Set the source output mode: Volts (voltage source) or Amps (current source).
End Type	Set the scan end type. Last/Fix/Off types are supported. <ul style="list-style-type: none"> <li>• Last: After sweep has finished running, always output the value of the last step.</li> <li>• Fix: After sweep has finished running, always output the value of the Normal mode setting.</li> <li>• Off: After sweep has finished running, the SMU turns off the output and stops the sweep function.</li> </ul>
Range	Set sweeping range. Support Auto/ Fixed range/ Best range. <ul style="list-style-type: none"> <li>• Auto: The optimized range will be switched automatically during the sweep output process.</li> <li>• Fixed range: Sweeps the output with a fixed range.</li> <li>• Best: Select a fixed range that covers all sweep values.</li> </ul>
Cycle Count	The number of cycle times. Indicates the total number of cycles to be run after the sweep is run. From the first output step to the last output step, it represents one cycle. If this value is 0, represents an infinite cycle.
Points	Set the number of sweep steps.
Step	Sets the sweep step value (incremental step value). Not applicable to Log and List sweep operations. When the sweep mode is Linear, the Points setting and the Step setting are in conflict with each other. When Points is set, the Step

Parameter	Description
	value is automatically generated; when Step is set, the Points value is automatically generated.
Single Step Cycle Count	Step cycle count, which refers to the number of times each step in the cycle is executed.
Start	Sets the sweep start value.
Stop	Sets the sweep end value.

### Trigger Setting

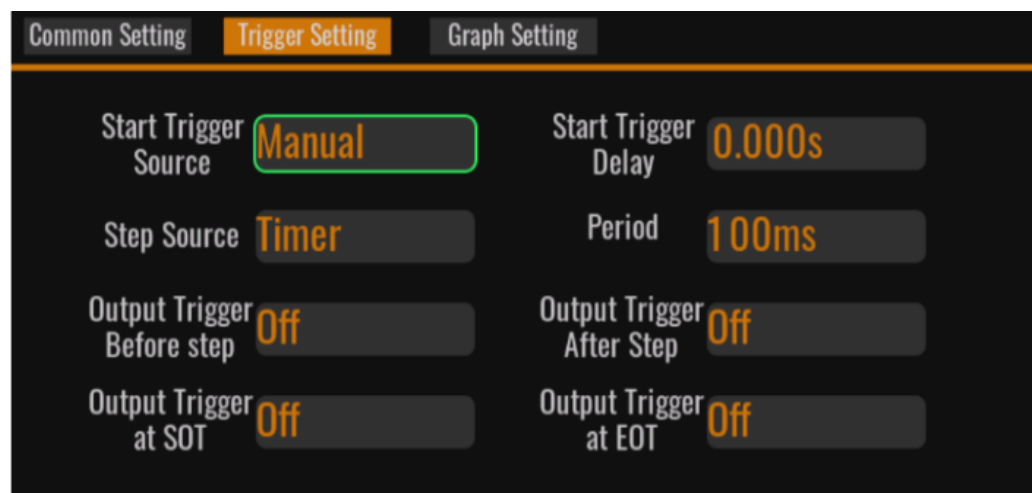

- **Start Trigger Source** supports the following methods:
  - Immediate: Immediate trigger mode.
  - Manual: Manual trigger mode.
  - Bus: Command (\*TRG) trigger method.
  - Trigger: IO trigger mode. Support Trigger1-Trigger8, total 8 IO interfaces.
  - Fiber: Fiber trigger mode. Support Fiber1-Fiber32, total 32 fiber bits. (- Used when interconnecting multiple SMUs)
- **Start Trigger Delay**: Indicates the waiting time between the receipt of the trigger signal and the execution of the first step, which can be set by the interface.
- **Step Source** supports the following methods:
  - Bus: Command (\*TRG) triggering method. Trigger delay time can be set by interface.
  - Trigger: IO trigger mode. Trigger delay time can be set by interface.
  - Fiber: Fiber optic trigger mode. Trigger delay time can be set by interface.
  - Timer: Timer trigger method. Timer also includes Auto and Manual, and the configuration logic is as follows:

- ◆ In Pulse mode, select Auto mode, step time = pulse width + pulse delay.
  - ◆ In Pulse mode, select Manual mode to automatically optimize the configuration of pulse delay and pulse width when the set step time is less than pulse delay + pulse width. The built-in algorithm of the instrument will modify the pulse delay first based on satisfying the pulse width.
  - ◆ In DC mode, when Auto mode is selected for PERIOD, STEP time = measure time + measure wait + match time (50us).
  - ◆ In DC mode, when Manual mode is selected for PERIOD, when period time < measure wait + measure time + match time (50us) is set, the configuration of measure wait and measure time is automatically optimized.
- **Output Trigger Before Step/After Step/at SOT/at EOT** supports the following methods, taking Trigger Before Step as an example:
    - Off: Disable the trigger.
    - Trigger: Trigger is generated by IO pin.
    - Fiber: Trigger is generated by a fiber optic signal.

### Graph Setting

- Line Num: Used to set the number of lines to be displayed (1-20).
- Volts Scale: Used to set the voltage display scale.
- Volts Invert: Used to set the voltage invert display switch.
- Amps Scale: Used to set the current display scale.
- AmpsScale: Used to set the current reverse display switch.
- Export Data: Used for data export. Export file format:

1	Model	IT2801-Single	
2	Function Mode	LINEAR_SINGLE	
3	Source Mode	Voltage	
4	Start Value	0.1	
5	Stop Value	10	
6	Points	1000	
7	Times(s)	Voltage(V)	Current(A)
8	0.83832	0.0999021	0.00129638
9	0.84032	0.109772	0.00131317
10	0.84232	0.119605	0.00133069
11	0.84432	0.12949	0.00134804
12	0.84632	0.139394	0.00136449
13	0.84832	0.149399	0.00138277
14	0.85032	0.159254	0.0013973
15	0.85232	0.169266	0.00141171
16	0.85432	0.179129	0.00142128
17	0.85632	0.189065	0.00144693
18	0.85832	0.198954	0.00145377
19	0.86032	0.208853	0.00147617
20	0.86232	0.218816	0.00148354
21	0.86432	0.228737	0.00150391
22	0.86632	0.238592	0.00151976
23	0.86832	0.248554	0.00153439
24	0.87032	0.258436	0.00154852
25	0.87232	0.268449	0.00156009

## Mode Details

### 1. Sweep output.

The Source Measurement Unit can output a variety of waveforms as shown below. Measurements can also be made for each sweep step.

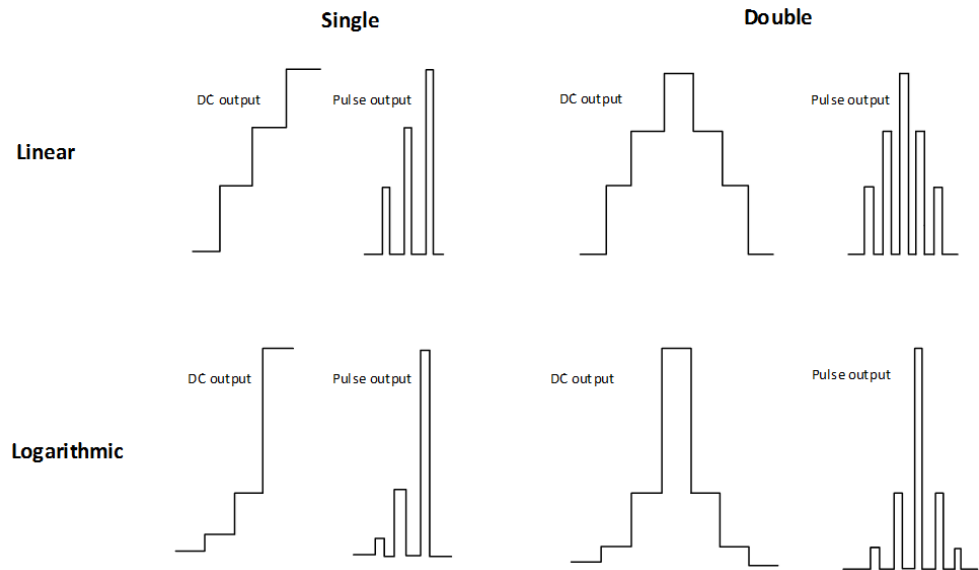

2. The sweep output process, as shown below.

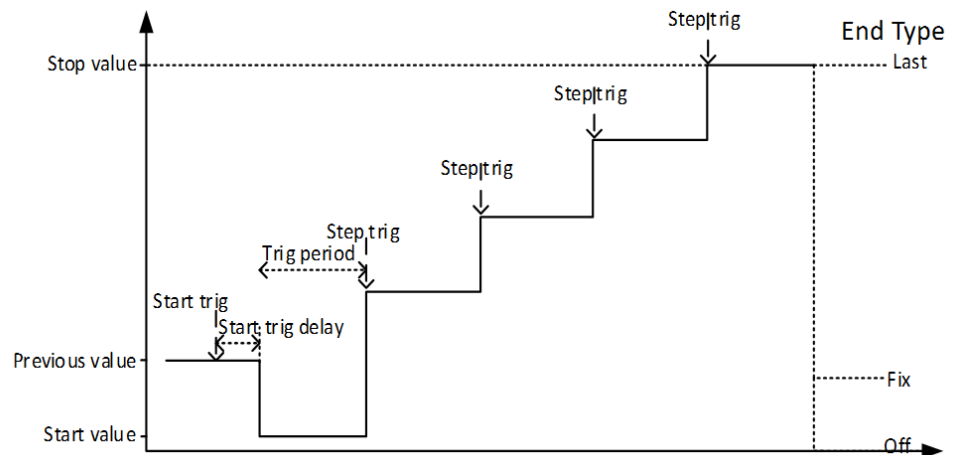

3. List sweeps.

A list sweep efficiently performs the output of a set waveform and measures the voltage or current at each output value. The entire sweep is controlled by a trigger system, initiated by a start trigger source and generating the output for each step by a step trigger source. If the trigger type is set to Timer, the output of each step can be triggered at regular intervals.

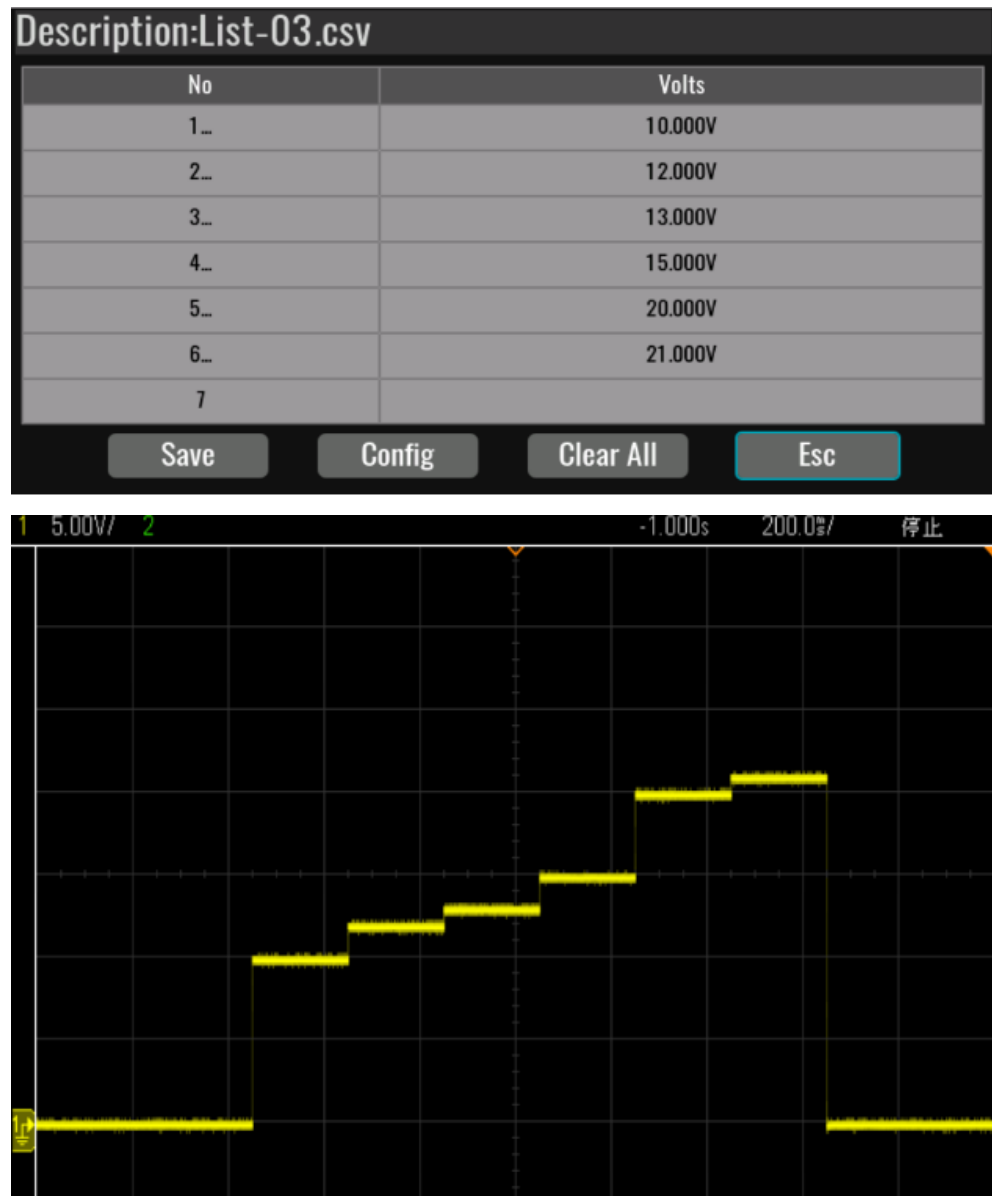

#### 4. Trigger output function.

In trigger output, signal output can be accomplished by start, pre-step, post-step, and end trigger signals.

- Output Trigger at SOT: A pulse signal can be output at the beginning of the sweep;
- Output Trigger Before step: A pulse signal can be output at the pre-step of each step of the sweep;
- Output Trigger After Step: A pulse signal can be output after each step of the sweep;
- Output Trigger at EOT: A pulse signal can be output at the end of the sweep.

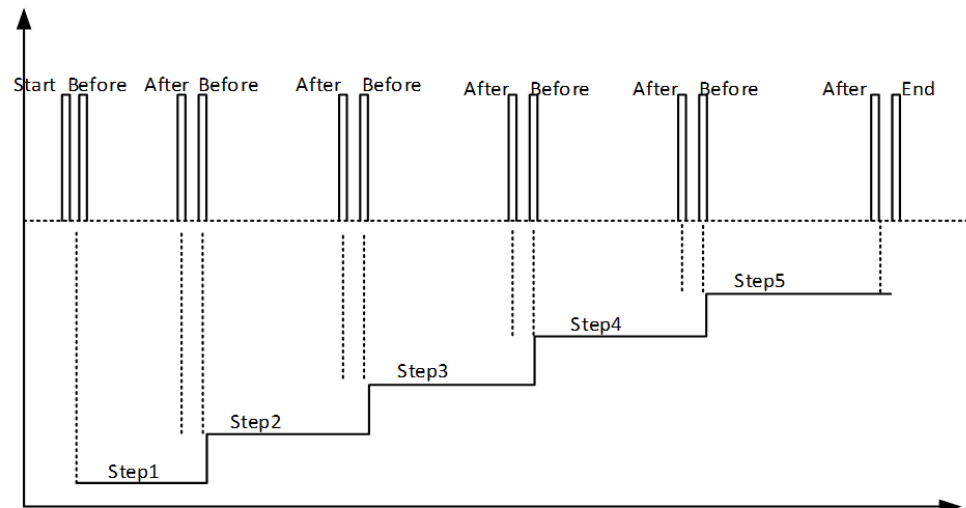

## Operation Example

1. Parameter Configuration: Press Setting to enter the parameter setting interface in Sweep mode.
  - Press Common Setting for the Common Setting menu.
    - Configure Mode: Sweep output mode, select Linear single.
    - Configure End Type: Output type at the end of sweep, select Last.
    - Configure Range: The range used during sweeps, select Best.
    - Configure Cycle Count: The number of sweep cycles, set to 1.
    - Configure Points or Step: The number of sweep points or the sweep step value. Set step to 11.
    - Configure Start: The sweep start value. Set to 0.
    - Configure Stop: The end value of the sweep. Set to 2, at this point, STEP will become 200mV.
  - Press Trigger Setting for trigger setting.
    - Configure Start Trigger Source: Set the start running trigger source. When this trigger signal is generated, sweep will run automatically. Set it to Manual.
    - Configure Start Trigger Delay: Indicates the waiting time between the receipt of the trigger signal and the execution of the first step, set to 0.
    - Configure Step Source: Indicates the trigger source for single step. After this trigger signal is generated, the sweep will run step by step, generating a signal and executing a step. If Timer is selected, the SMU will generate step triggers periodically according to the configured period time. Set to Timer.

- Configure PERIOD: When STEP SOURCE is TIMER, it indicates the time interval of the step trigger generated by the cycle. Set it to 100ms.
- Configure Output Trigger Before step: The pre-step output trigger signal for each step of the sweep. Select off.
- Configure Output Trigger After step: The post-step output trigger signal for each step of the sweep. Select off.
- Configure Output Trigger at SOT: Indicates the sweep start output trigger signal. Select off.
- Configure Output Trigger at EOT: Indicates that the trigger signal is output at the end of the sweep. Select off.
- Press Graph Setting for the graphic display setup menu. This will work fine without configuration.
  - Configure Line Num: Set the number of Curves to be displayed in the main view interface. Set it to 1.
  - Configure Volts Scale: Sets the axis display mode corresponding to voltage. The setting is linear.
  - Configure Volts Invert: sets whether the voltage display is inverted. Set to off.
  - Configure Amps Scale: Sets the axis display mode corresponding to the current. The setting is linear.
  - Configure Amps Invert: sets whether the current display is inverted. Set to off.

## 2. Starting to run.

Return to the sweep main view screen, first turn the output On, then press the Run button. At this time, the sweep function is on, waiting for the start trigger signal.

The Start Trigger Source is set to Manual, so it needs to be triggered by a trigger key (**[Trig]**). The Sweep then start running. Sweep output starts from 0V, each step is 0.2V, the execution time is 100ms, total 11 steps. After 1s time, execution to the last step 2V, the last step output 100ms and then the sweep ends. Since End Type is set to last, the last value (last step) is continuously output after the end of Sweep.

Users can select the main interface data list to view the voltage and current values output at each step.

## 3.8 Config Menu Function

### I Limit / V Limit

I Limit / V Limit is set to prevent equipment damage due to overvoltage or overcurrent. The limit value limits the output voltage or current of the source meter. The SMU maintains the source output until the limit is reached and then outputs as a constant voltage source or constant current source after the limit is reached.

The current source mode can be configured for the voltage limit value, and the voltage source mode can be configured for the current limit value. The limit value is set with the same accuracy as the output set value.

The current range of this series of SMUs is described below:

Range	Setting interval	Remark
10nA	[-10.5nA, -1nA], [1nA, 10.5nA]	Supported on IT2805 and IT2806 models
100nA	[-105nA, -1nA], [1nA, 105nA]	Supported on IT2805 and IT2806 models
1uA	[-1.05uA, -0.01uA], [0.01uA, 1.05uA]	
10uA	[-10.5uA, -0.1uA], [0.1uA, 10.5uA]	
100uA	[-105uA, -1uA], [1uA, 105uA]	
1mA	[-1.05mA, -0.01mA], [0.01mA, 1.05mA]	
10mA	[-10.5mA, -0.1mA], [0.1mA, 10.5mA]	
100mA	[-105mA, -1uA], [1mA, 105mA]	
1A	[-1.05A, -0.01A], [0.01A, 1.05A]	
1.5A	[-1.575A, -0.015A], [0.015A, 1.575A]	Supported on IT2805
3A	[-3.15A, -0.03A], [0.03A, 3.15A]	Supported on IT2806
10A	[-10.5A, -0.1A], [0.1A, 10.5A]	IT2806 Pulse Mode Support

**Note**

If the current limit is set too small, it will increase the stabilization time of the voltage.

## Measurement range setting

The device offers the following range modes for voltage and current:

- Fixed: The device uses the specified range.
- Automatic range selection (Auto): The device automatically selects the range with the best resolution for the source output and limit values.

The setting of Auto Range Low-Limit (Config->Measure->Auto Range Low-Limit) affects the selection of the minimum auto range of the device.

Example: In the voltage mode of the device, if Auto Range Low-Limit->Volt is set to 2V, the range is set to Auto, and the set value of voltage is 200mV, the device will automatically select the 2V range for output when the device is turned on.

In Pulse Mode, when setting Auto range, it does not switch range in real time during output, the device is automatically set to the smallest range that will cover the Pulse Base and Peak values.

- Best: When used in Sweep mode, the device automatically uses the smallest range that will cover the entire sweep output.

Output and measurement range: To prevent the output power of the SMU from exceeding the upper limit, the voltage and current of the SMU are limited as follows:

IT2801		
DC	1050V	10.5mA
	210V	105mA
	21V	1.05A
IT2805		
DC	210V	105mA
	21V	1.05A
	9V	1.575A
IT2806		
DC	210V	105mA
	21V	1.05A
	9V	3.15A
Pulse	210V	1.05A
	12.5V	10.5A

## Measurement time

Measurement time is used to set the integration time (the time it takes to measure the input signal) for AD sampling. The measurement time affects the accuracy of the measurement, the amount of read noise, and the final sampling rate of the device. Measurement time offers two ways to set it. One is based on the power line period NPLC (when the power line period is 60hz, the measurement time for 1PLC is 16.67ms); the other is the aperture time Aperture, which is set to an accuracy of 10us.

Setting interval for measurement time:

Measurement unit	Setting interval
Aperture	[10us, 2s]
NPLC(50Hz)	[0.0005, 100]
NPLC(60Hz)	[0.0006, 120]

### DC mode timing diagram:

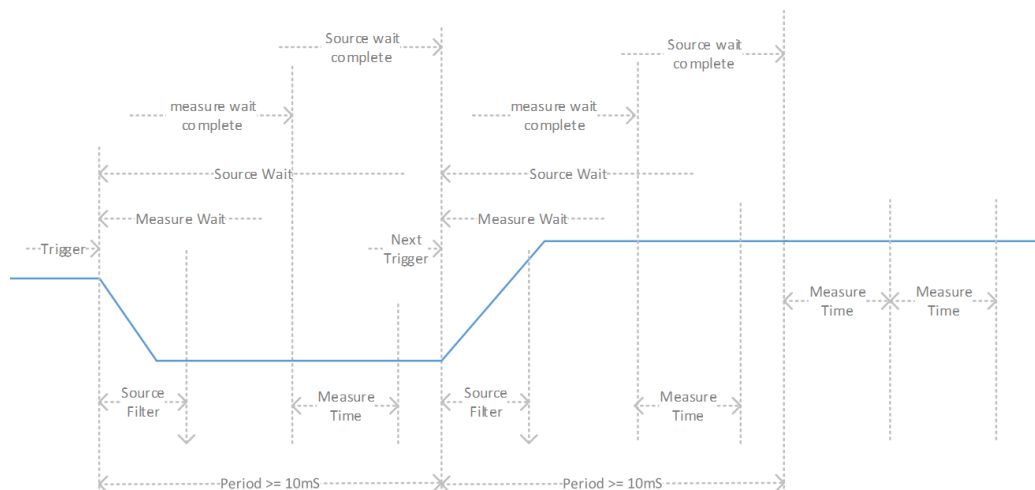

- **Source Filter:** Source filter time, used to obtain a stable output.
- **Measure Wait:** Measurement wait time, indicates the delay time from the reception of a valid trigger signal to the start of the measurement.
- **Source Wait:** Source output wait time, indicates the time from receiving a valid trigger signal to the completion of a single excitation and waiting for the next trigger.
- **Measure Time:** The time required for the measurement, determined by the measurement speed set in the Config Measure interface.

Measurement process includes Measure Wait Time and Measure Time, when the device is in Auto automatic timed trigger mode or single trigger mode, the time from the set value change to acquire one measurement data is: Measure Wait Time + Measure Time; when the device is in Auto automatic timed trigger mode, and there is no change of the set value, the time to acquire one measurement data is Measure Time; the time interval between acquiring to two measurements in Auto mode is not less than 10ms of the cycle time of Auto.

#### Pulse mode timing diagram:

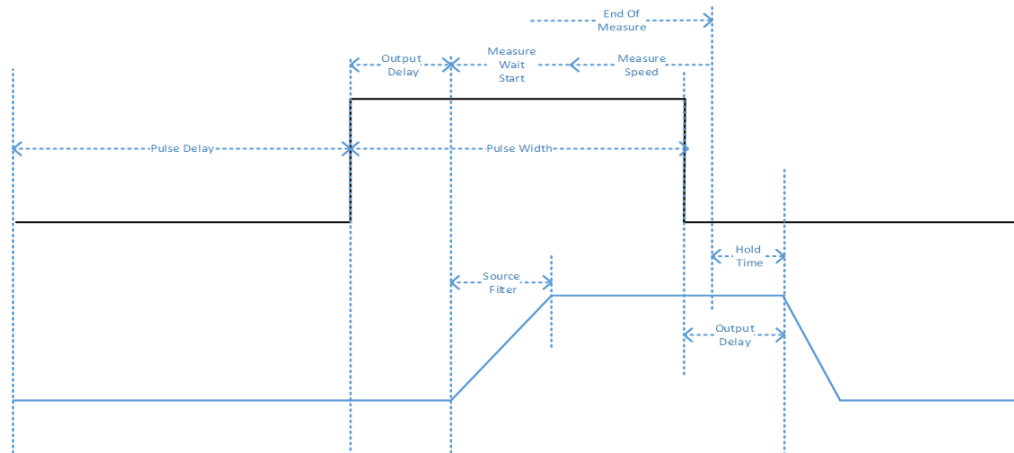

Measurement time in Pulse Mode is affected by Pulse Width and Measurement Waiting Time, the device will prioritize the Pulse Width time and adjust the measurement time according to the Measurement Waiting Time set by the user. Firstly, the source meter will ensure that at least one measurement will be completed and the minimum time interval for one measurement is 10us, and secondly, the set value of the measurement time can not exceed Pulse Width - Measure Wait - Holding Time, in which the time reserved for Holding Time is 20us. When Pulse Mode is on, the measurement time setting is not limited, but the actual time is calculated by the source meter according to the rules, and the Real Measure Speed will be displayed on the interface.

#### Pulse Output

The IT2800 series SMUs can output pulsed voltage or current and can apply Pulse mode in Sweep mode. Turning on Pulse mode, the SMU will automatically turn off the source wait time and cannot be set, the cycle time of the pulse is composed of Pulse Width and Pulse Delay together. The source meter outputs the set Pulse Peak during Pulse Width time, and the source meter outputs the set Pulse Base during Pulse Delay time.

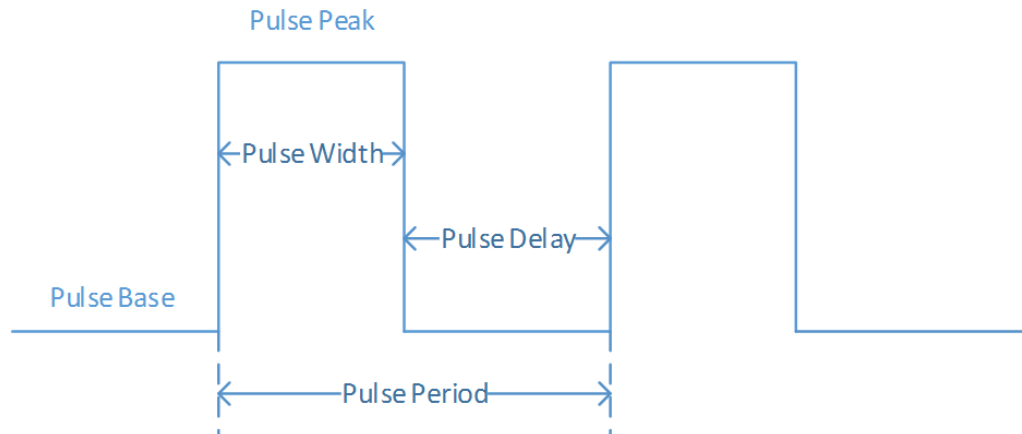

Pulse mode supports **short-term overpower output** on **IT2806** models only. In this case, the base value of the pulse, the maximum value of the pulse width and the minimum value of the pulse delay are limited to ensure that the device will not be damaged due to prolonged over-power output.

The IT2806 provides a pulse output that exceeds the power limit, with the energy for the pulse being provided by an internal capacitor.

Each pulse peak output consumes energy from the capacitor, after which the capacitor starts to charge, and it is necessary to ensure that the capacitor has enough charging time to output the next pulse peak.

The pulse mode can be set to 10A range, the voltage can be set to 20V range, but the maximum voltage value is 12.5V, the maximum pulse base value is 500mA, the maximum pulse width time is 1ms, and the minimum delay time of the pulse is pulse width\*40.

It can also be set to 200V range, the current range is set to 1A, the maximum pulse base value is 50mA, the minimum pulse width time is 1ms, and the minimum pulse delay time is pulse width\*40.

#### IT2801 Maximum Pulse Width and Maximum Duty Cycle:

	Maximum voltage	Maximum peak current	Maximum base current	Maximum pulse width	Maximum duty cycle
Pulse	1050V	10.5mA	10.5mA	1000s	100%
	210V	105mA	105mA	1000s	100%
	21V	1.05A	1.05A	1000s	100%

#### IT2805 Maximum Pulse Width and Maximum Duty Cycle:

	Maximum voltage	Maximum peak current	Maximum base current	Maximum pulse width	Maximum duty cycle
Pulse	210V	105mA	105mA	1000s	100%
	21V	1.05A	1.05A	1000s	100%
	9V	1.575A	1.575A	1000s	100%

**IT2806 Maximum Pulse Width and Maximum Duty Cycle:**

	Maximum voltage	Maximum peak current	Maximum base current	Maximum pulse width	Maximum duty cycle
Pulse	210V	105mA	105mA	1000s	100%
	21V	1.05A	1.05A	1000s	100%
	9V	3.15A	3.15A	1000s	100%
Pulse	12.5V	10.5A	500mA	1ms	2.50%
	210V	1.05A	50mA	2.5ms	2.50%

Configure the priority of the pulse output:

- Selecting the base value priority mode, the SMU outputs the base value of the pulse first after receiving a valid trigger signal, and outputs the peak value of the pulse after the pulse waiting time is over;
- Selecting the peak priority mode, the SMU outputs the peak value of the pulse first after receiving a valid trigger signal, and outputs the base value of the pulse after the pulse width time is over.

Pulse output and measurement timing:

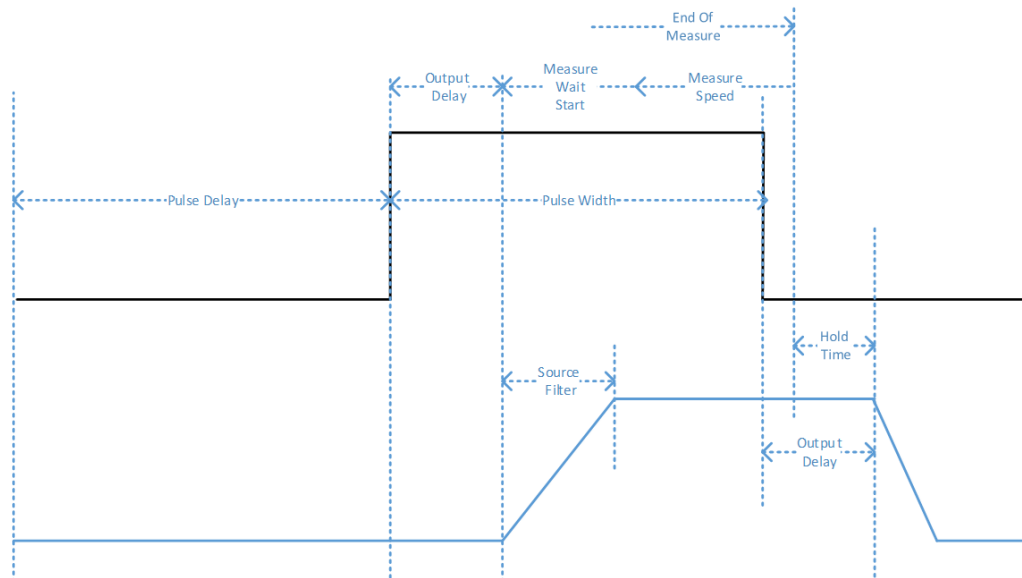

- Pulse Delay: Pulse delay time, output pulse base value.
- Output Delay: Output delay time (30us), indicating the delay time between the device issuing the output command and the actual output.
- Hold Time: Hold Time (20us), indicates the time to perform other operations (math calculations, storage, scanning, etc.) after the source output is measured.
- Measure Wait: Measurement wait time, indicates the delay time between the pulse peak output and the start of measurement.
- Measure Time: Measurement time, indicates the time between the start of measurement after the measurement wait time has expired and the time when the measurement result is obtained.

### CAUTION

In order to ensure that the pulse peak can be measured accurately, it is necessary to assist in the measurement waiting time. By turning on the automatic measurement waiting time, the SMU will automatically configure the appropriate measurement waiting time according to the present set range to ensure that the measurement starts at the point where the peak rise is completed and the output is stabilized. In case the output stabilization time is longer due to the influence of external test equipment or modification of the output filtering time for a more stable output, it is necessary to increase the measurement waiting time in order to ensure the measurement of a stable pulse peak.

## Output Filter

The Output Filter is used to obtain an output that is clean and free of any output spikes or overshoot. Setting the filter parameters increases the stabilization time of the output.

- **Filter State:** Turns the output filter on or off. Turns the output filtering on to get a clean output without any output spikes and overshoots.
- **Auto Filter:** Enables or disables automatic filtering. Auto Filter automatically determines the stabilization time according to the set voltage range, current range, voltage value or current value.
- **Time Constant:** Set the filtering time, setting range: 10us - 10ms, can only be set when auto filtering is off.

The set filter time is the rise time from the present value to 0.707 times the target value.

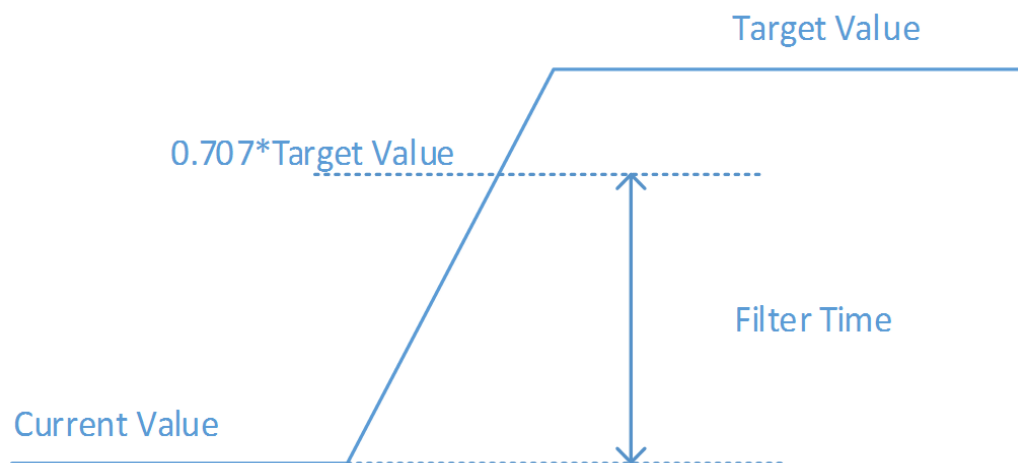

## Output Off State

The output off state can be set to High-z or Zero.

- **High-z:** The output goes into a high resistance state when the output is OFF and the output relay is disconnected. This disconnects the external circuit from the SMU's output connector.
  - In voltage source mode, the output is turned off, the current limit range and current limit value remain unchanged, the voltage range is set to the maximum range, and the voltage setting value remains unchanged.
  - In current source mode, the output is turned off, the voltage limit range is set to the maximum range, the voltage limit value remains unchanged, the current range remains unchanged, and the current value is set to zero.

- User settings are restored when the output is turned on.
- Zero: Fast zeroing when the output is OFF.
  - In voltage source mode, the output is turned off, the current limit value range is 1uA, the current limit value is 1uA, the voltage value output is 0V, and the voltage range is unchanged.
  - In current source mode, the output is turned off, the voltage limit value range is 2V, the voltage limit value is 20mV, the current output value is 0, and the current range remains unchanged.
  - User settings are restored when the output is turned on.

### Automatic output on/off function

Auto output turn on: Turning on this function, the SMU will automatically turn on the output after receiving a valid trigger signal and before the trigger output takes effect.

Auto Output Off: Turn on this function to automatically turn off the output when the triggered output is completed and the measurement is finished.

### High capacitance mode (supported by model IT2805, IT2806, IT2805R, and IT2806R only)

The **Voltage Source** output mode can support **HC Mode** high capacitance mode on or off.

High capacitance mode allows efficient measurement of capacitive loads greater than 0.01uF.

If the measurement result data is unstable, set this function to ON and the measurement data can be stabilized. This function is effective for measuring capacitive devices up to 50uF.

The high capacitance mode applies to the following source/measurement conditions.

- Operating modes: voltage source and current measurement.
- Measurement adjustment range mode: fixed range.
- Measurement range: 1 uA to 10 A.

## 3.9 Meas ohms Function

### Resistance Measurement

The SMU provides resistance measurement. When resistance measurement is turned on, the device automatically switches to current source mode.

The device offers two resistance measurement modes, manual and automatic.

Fixed range resistance measurement:

Resistance Range	Test Current
2Ω	1A
20Ω	100mA
200Ω	10mA
2kΩ	1mA
20kΩ	100uA
200kΩ	10uA
2MΩ	1uA
20MΩ	100nA
200MΩ	10nA

**Note: The IT2801 model supports a maximum of 20MΩ range.**

Using fixed gear for resistance measurement, the source meter will adjust the current range for measurement according to the selected resistance range to ensure the accuracy of the test. When selecting automatic range, the device automatically adjusts to the appropriate range for measurement.

Measurements can be made using either the 2-wire or 4-wire system, and the 4-wire system is recommended to ensure the accuracy of resistance measurements. The 4-wire measurement method minimizes or eliminates the effect of the voltage drop caused by the resistance of the test leads on the resistance measurement of the DUT.

Resistance offset compensation effectively compensates for measurement errors due to thermal electromagnetic fields (VEMF) in the measurement of resistors with lower resistance values. When resistance compensation is turned on, the channel will make 2 measurements and return the result calculated by the formula  $R_{comp} = (V_2 - V_1) / (I_2 - I_1)$ . Where  $V_1$  and  $I_1$  are measurements under 0A conditions.

## 3.10 Meas math Function

The IT2800 series provides mathematical calculations using the measurement result data. The calculation results can be read with the Trace function, and the results can be used for limit value testing.

### Expression Introduction

Resources used in mathematical expressions:

- Constants: Expressions may contain integers and floats, and floats may be in exponential form.
- Variables: SMU outputs and measurements are used as variables in the math operation process. Variables are categorized into scalars and vectors, with scalars being single measurements and vectors (arrays) being used for multiple measurements. When the limit test uses math calculations as test data and the math formula contains vectors, the device performs multiple outputs and measurements as many times as the number of arrays. When the math function is turned on in Fixed mode, when the variable is a scalar, one calculation is made for each output and measurement, and when the variable is a vector (array), measurements are made after each output and measurement of the number of arrays.

Variable		Description
Scalar	Vector	
VOLT	VOLT[n]	Voltage measurement data
CURR	CURR[n]	Current measurement data
WATT	WATT[n]	Power measurement data
RES	RES[n]	Resistance measurement data
SOUR	SOUR[n]	Source output setting data
TIME	TIME[n]	Time measurement data

- Math operators: Math expressions support the following operators

Priority	Operator	Description
High	()	Parentheses
.	+ and -	Unary addition and unary subtraction operators
.	* and /	Multiplication and division operators
Low	+ and -	Addition and subtraction operators

- Primary functions: mathematical expressions also support some primary functions

Name	Description
In	Natural logarithmic function
LOG	Logarithmic function
SIN	Sine function
COS	Cosine function
TAN	Tangent function
EXP	Exponential function
SQRT	Square root function

Functions LOG and In perform calculations by taking the absolute value of constants within the function, so if a negative value is specified, it is calculated as a positive value.

### Limit Testing Utilizing Mathematical Calculation Results

If mathematical calculation results are set as the basis for limit testing, the mathematical function must first be activated, and the relevant mathematical formula selected. When the variables in the mathematical formula are scalars, the limit testing script receives a valid trigger signal, performs one output and measurement, sends an interrupt signal to the SOC, and waits for the SOC to provide feedback on the mathematical calculation results to the script. After receiving the feedback, the limit testing continues. In the case of vector variables (arrays), when the script receives a valid trigger signal, it performs output and measurement for each element in the array.

## POWER

$$\text{POWER} = \text{VOLT} * \text{CURR}$$

## OFFCOMPOHM

$$\text{OFFCOMPOHM} = (\text{VOLT}[1] - \text{VOLT}[0]) / (\text{CURR}[1] - \text{CURR}[0])$$

In this context, VOLT[0] and CURR[0] represent data obtained by measuring the output current after applying current to the device. On the other hand, VOLT[1] and CURR[1] represent data obtained by measuring the output voltage after applying zero current to the device. This functionality effectively reduces errors in resistance measurements.

## VARALPHA

$$\text{VARALPHA} = \log(\text{CURR}[1]/\text{CURR}[0]) / \log(\text{VOLT}[1]/\text{VOLT}[0])$$

CURR[0] and VOLT[0] represent measurement data at a specific point on the potentiometer and the nonlinear I-V characteristic curve. On the other hand, CURR[1] and VOLT[1] represent data at another point.

## VOLTCOEF

$$\text{VOLTCOEF} = (\text{RES}[1] - \text{RES}[0]) / (\text{RES}[1] * (\text{VOLT}[1] - \text{VOLT}[0])) * 100\%$$

The voltage coefficient is the ratio at which the resistance changes with respect to voltage.

## User-Define

Custom expression mode allows users to define their own expressions in the following interface.

1. Enter the **Menu**→**Meas Math** to select **Function** as **User-Define**.

The interface is shown in the following image.

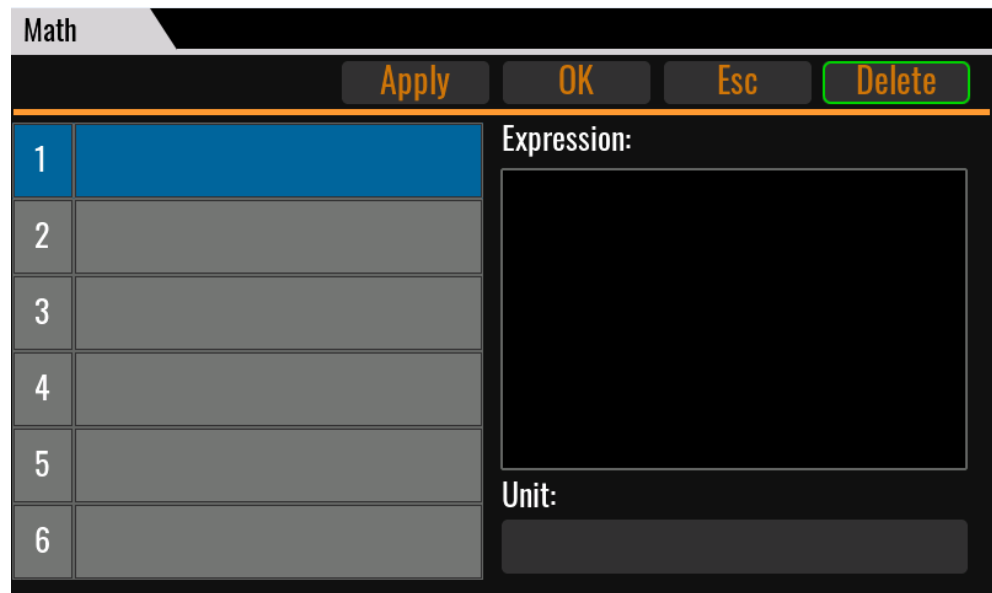

2. Double-click on the left-side cell to edit the expression name, as shown in the following image.

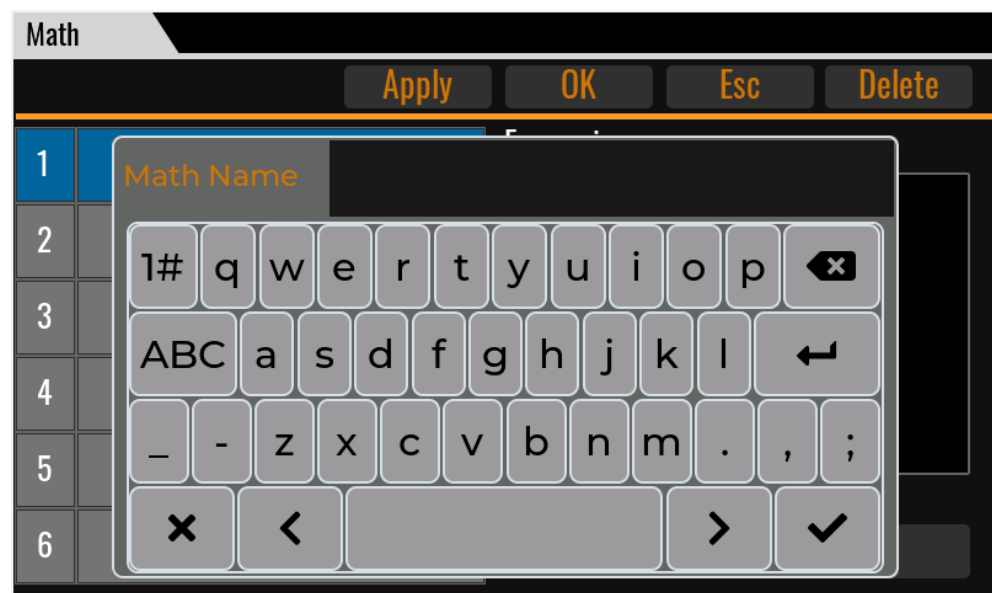

3. Double-click on the text box area below **Expression** to edit the custom expression.

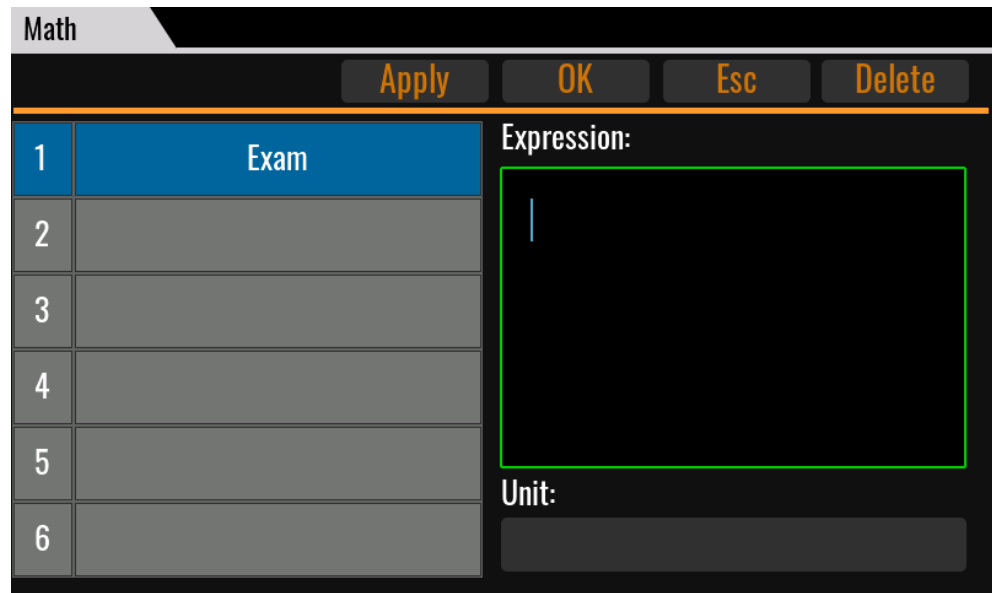

4. Edit the custom expression in the following interface.

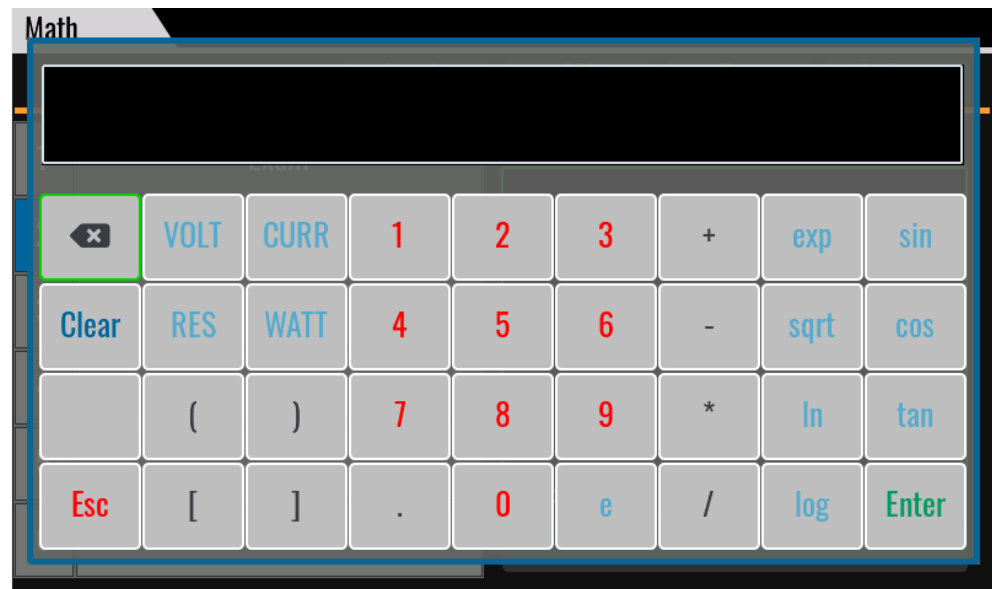

5. After completing the expression editing, press **[Enter]**.
6. Double-click on the text box area below **Unit** to edit the unit.

After completing the custom expression editing, the interface should appear as shown in the following image.

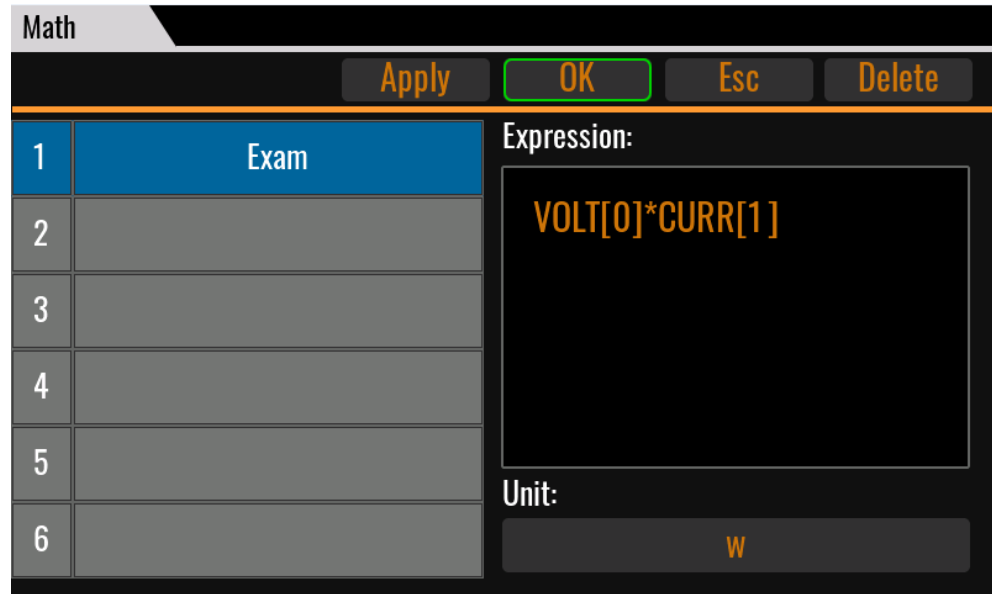

- Click **[OK]** to save the custom expression.

After applying, the display appears as shown in the following image.

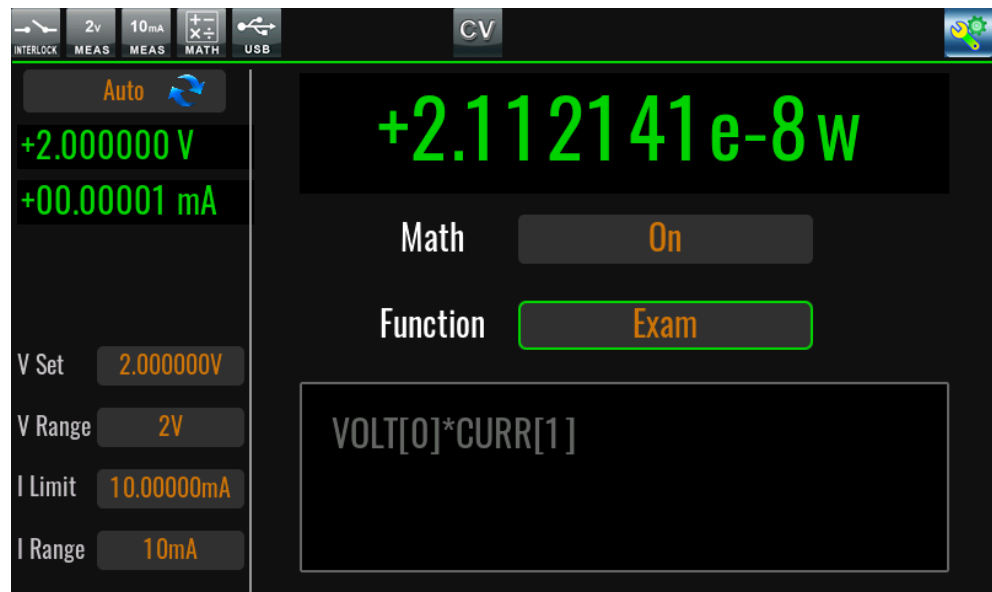

## 3.11 Trace Function

### Function Introduction

The Trace Buffer feature is used to collect measurement and limit testing result data. For IT2801 and IT2806, it supports 1,000,000 sets of data, while IT2805 supports 300,000 sets of data. Each data set includes voltage measurement values, current measurement values, resistance measurement values, time, limit testing status, and source output values.

## Data Output Formatting

The IT2800 allows configuration of the data output format. You can use the command **SENSe[c]:FORMat:ELEMents:SENSe** to configure the output elements. The available elements include voltage measurement values, current measurement values, resistance measurement values, time, status, and source output values. The terminator 0x0a will be appended to the end of each data.

Configure the data type of the returned values using the command **SENSe[c]:FORMat[:data] ASCII|REAL32|REAL64**.

- When the data type is configured as **ASCII**, the device formats the returned values as string data. If configured for three elements, the example return would be: +1.000001E-06, +1.000002E-06, +9.999999E-07.
- When the data type is configured as **REAL32**, the returned data length is 4 bytes. The data is formatted as follows: #<length of byte count<data byte length<byte>...<byte><terminator>

For example, with a data set containing 2 elements, the data header is #18. The data includes 2 four-byte values and 1 byte for the terminator. For elements other than the status, all are in float format.

Additionally, you can configure the order of data bytes using the command **SENSe[c]:FORMat:BORDER NORMAl|SWAPped**. When configured as "Normal", the data is transmitted in the order of byte1 to byte4. When configured as "SWAPped", the data is transmitted in the order of byte4 to byte1.

- When the data type is configured as **REAL64**, the returned data length is 8 bytes. The data is formatted as follows: #<length of byte count<data byte length<byte>...<byte><terminator>

For example, with a data set containing 2 elements, the data header is #216. The data includes 2 eight-byte values and 1 byte for the terminator. For elements other than the status, all are in double format.

Additionally, you can configure the order of data bytes using the command **SENSe[c]:FORMat:BORDER NORMAl|SWAPped**. When configured as "Normal", the data is transmitted in the order of byte1 to byte8; when configured as "SWAPped", the data is transmitted in the order of byte8 to byte1.

## How to Use

This functionality is implemented through SCPI commands. The detailed explanation of the functionality is as follows:

- **SENSe[c]:TRACe:CLEAr**

Clear the data in the data buffer and set the Trace function to NEV (Never).

- **SENSe[c]:TRACe:DATA? [offset[, size]]**

Returns the data from the data buffer. The format of the returned data is determined by **SENSe[c]:TRACe:FEED**.

The parameter "offset" is used to indicate the starting position for reading data. The parameter can be specified as n|CURRent|STARt. When offset=n, it specifies starting from the nth data point. When offset=CURRent, it indicates reading from the presently unread position. When offset=STARt, it specifies reading from the starting position of the Trace.

The parameter "size" is used to specify the length of the data to be read. It can be configured from 0 to the maximum number of data buffer entries. If this parameter is not set, it reads all data starting from the offset position.

The return value type is NR3. For the specific data format, please refer to **Data Output Formatting**.

- **SENSe[c]:TRACe:FEED SENSe|MATH**

Specify the data placed in the Trace buffer. When set to "SENSe", the Trace buffer stores specified measurement result data, and you can use the **SENSe[c]:FORMat:ELEMents:SENSe** command to configure the data type. Available elements include voltage measurement values, current measurement values, resistance measurement values, time, status, and source output values. When set to "MATH", the Trace buffer stores specified calculation result data, including calculation results, time, and limit testing status. You can configure data elements using the **SENSe[c]:FORMat:ELEMents:CALCulate** command.

- **SENSe[c]:TRACe:FEED:CONTrol <NEXT|NEVer|ALWays>**

Set the control mode for the Trace buffer.

- NEVer: Disables the Trace buffer function, and the **SENSe[c]:TRACe:POINts** command can be used.
- NEXT: Enables the Trace buffer function until the buffer is full. Once the buffer is full, it automatically sets the Trace function to NEVer, disabling the Trace function.
- ALWays: Enables the Trace function and operates in continuous storage mode. If data is not read promptly, it will be overwritten in a circular manner.

- **SENSe[c]:TRACe:FREE?**

Returns the available space and total space in the Trace buffer. For example: 999999,1000000; indicating a total of 1000000 spaces, with 999999 spaces available.

- SENSe[c]:TRACe:POINts:ACTual?**  
 Returns the number of data points already saved in the Trace buffer.
- SENSe[c]:TRACe:POINts**  
 Sets the size of the Trace buffer, configurable when the Trace function is in NEVer mode. The range for IT2801 and IT2806 is 1-1000000; for IT2805, the range is 1-300000.
- SENSe[c]:TRACe:TSTamp:FORMat DELT|ABSolute**  
 Sets the reading rule for time in the Trace buffer. When set to ABS, the returned time is the increment value from the first data time. When set to DELT, the returned time is the increment value from the previous data.

*RST	Reset SMU
SENS:TRAC:CLE	Clear Trace data and enter NEV mode
SENS:TRAC:POIN 2	Set Trace buffer size to 2
SENS:TRAC:FEED SENS	Set Trace buffer measurement data
SENS: TRAC: FEED: CONT NEXT	Set Trace control mode to NEXT
SENS: FORM: ELEM: SENS VOLT	Set Trace data element to voltage
SENS:FORM ASCII	Set Trace return value type to string
FUNC:TRIG:CONT 1	Set automatic triggering
OUTP 1	Turn on the output
SENS:TRAC:FREE?	Query the number of free buffer entries and total buffer entries
SENS:TRAC:POIN:ACT?	Query the number of stored data points
SENS:TRAC:DATA?	Retrieve all buffered data

## 3.12 Trigger Function

### Trigger Source

The IT2800 series SMU can choose from the following trigger sources:

- **AUTO:** Internal Automatic Timed Trigger

When set to AUTO, internal automatic triggering occurs, and the minimum time interval between two triggers is 10ms.

- **Manual:** Manual Trigger

Press the **[Trig]** key to generate one trigger.

- **Bus:** Bus Trigger

Sending the command **\*TRG** or **TRIG:INIT** generates an immediate trigger.

- **TRIG1-TRIG8:** IO Pin Trigger

External DIO1-DIO8 Signals as Trigger Source

Schematic Diagram for External Port Trigger Connection:

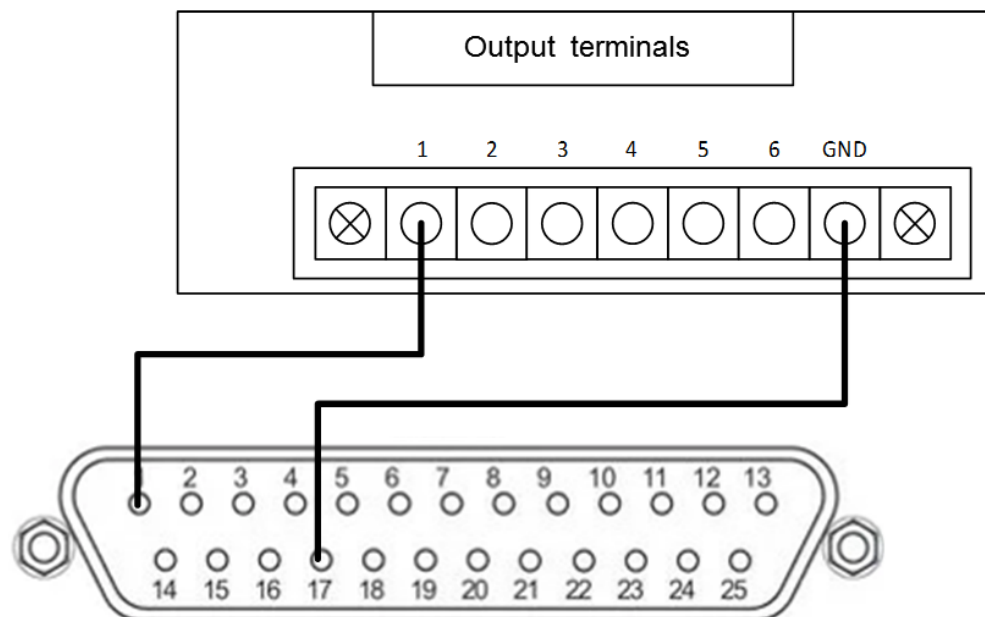

Connect the output terminal Pin1 of the external device to pin 1 of the SMU device's DB25 connector and connect the GND to pin 17. Set **System -> I/O -> Function** to **Trig-in** for trigger input, and set **System -> I/O -> Reverse** to **Off** (disable IO level inversion). When the external device generates a falling edge on pin 1, it triggers a valid event. If **System -> I/O -> Reverse** is set to **On** (enable IO level inversion), it directly triggers a valid event.

- **Fiber1-Fiber32:** Fiber Optic Trigger

Using Fiber Optic as Trigger Signal

The schematic diagram for fiber optic connection is as shown in the following figure:

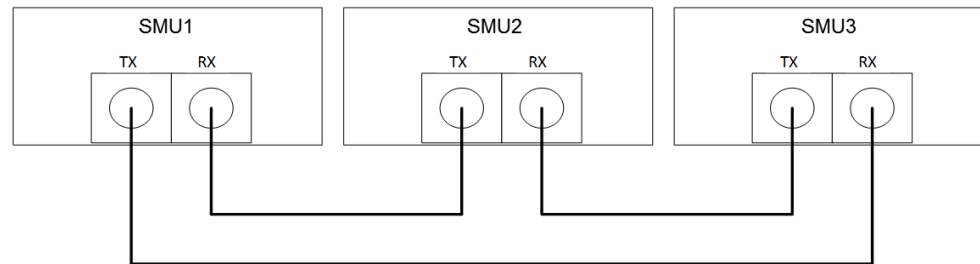

The fiber optic connection is arranged in a daisy-chain configuration. For example, with three devices connected, Device 1's RX is connected to Device 2's TX, Device 2's RX is connected to Device 3's TX, and Device 3's RX is connected to Device 1's TX. The fiber optic interface provides a 32-bit signal and can be used as a trigger source.

## Trigger Output Function

The IT2800 also supports trigger output functionality with two available trigger modes: Source and Sense.

- **Source:** The device generates a pulse output signal on the external IO port or fiber optic interface simultaneously with the output.
- **Sense:** The device generates a pulse output signal on the external IO port or fiber optic interface at the beginning of the measurement.

When selecting DIO for trigger output, you need to go to the **System -> IO** interface to configure the selected DIO. If the chosen trigger output for Source is **Trig1**, you should configure **DIO-1 -> Functon** as **Trig-out**, and set the width of the trigger pulse.

## Trigger Function Flowchart

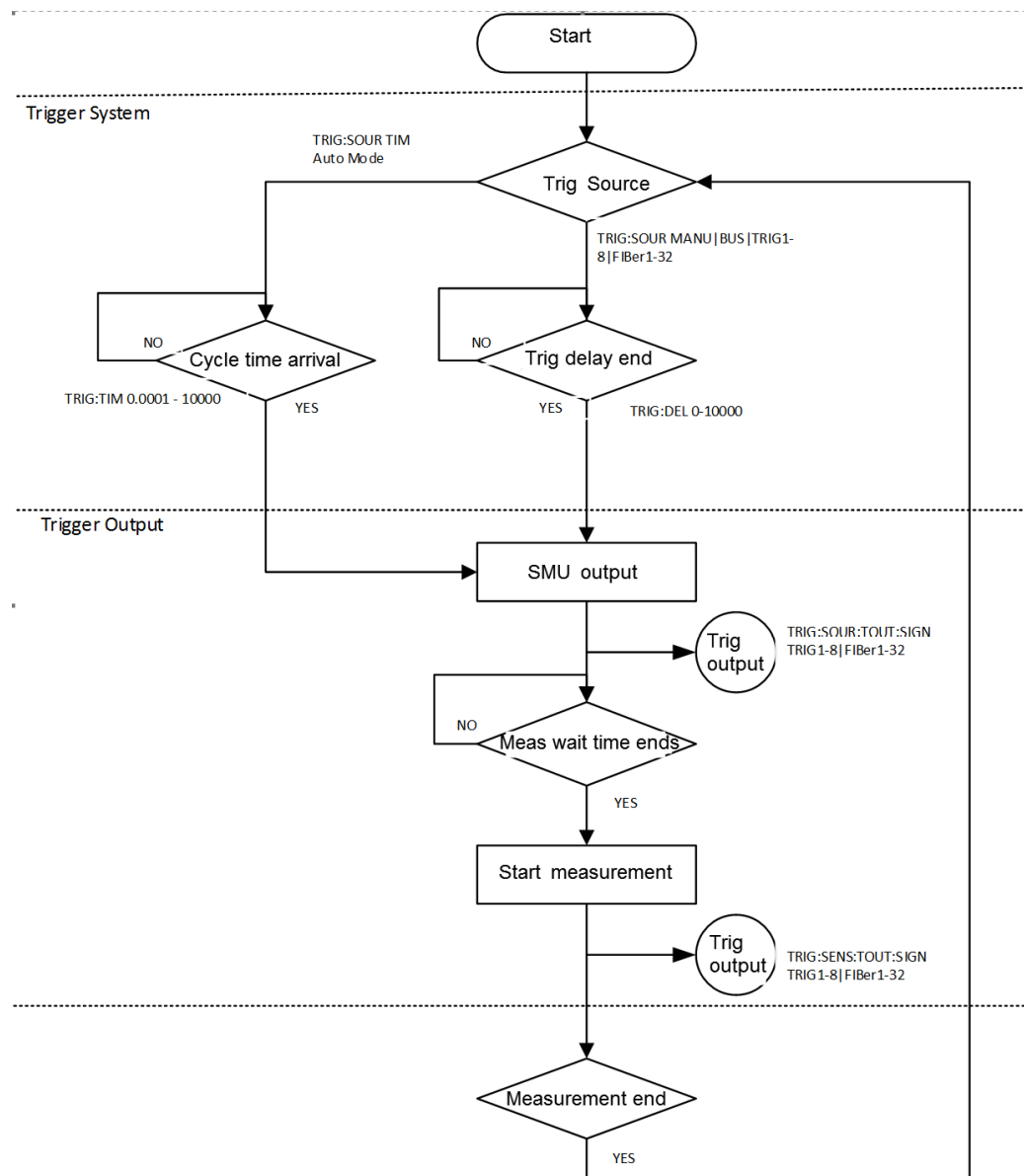

### 3.13 Fiber Optic Synchronization Trigger Function

The triggering function is used for the synchronization of multiple IT2800 SMUs in a fiber optic interconnection setup. A specific trigger signal is transmitted over the fiber optic network, enabling synchronized triggering among the IT2800 SMUs. If the synchronization feature is enabled and the following conditions are met, multiple machines can perform synchronized triggering operations.

- The fiber optic cables are correctly connected.

- Confirm that synchronization is in a normal state.
- This feature cannot be configured in standalone mode; it must be configured in either master or slave mode.
- Open the trigger synchronization feature in the **System**→**Fiber** interface.
- In normal mode, configure synchronous triggering by navigating to **Config**→**Advanced Setting**→**Trigger Source** and changing the trigger source to **Fiber**.
- In Sweep mode, configure synchronous triggering by navigating to **Sweep**→**Setting**→**Trigger Setting**→**Start Trigger Source / Step Source** and changing the trigger source to **Fiber**.

## Parameter Details

**System**→**Fiber** menu described as below:

Parameter	Description	Setting Range
Trig1_in->fiber25	IO1 triggering is converted to Fiber25 trigger signal. Set IO1 as Trig in in Menu > System > I/O > IO1. When an external stimulus signal is applied to IO1, triggering conditions are met, and it is then converted to a Fiber25 trigger signal.	On: Turn on
		Off: Turn off
Trig2_in->fiber26	IO2 triggering is converted to Fiber26 trigger signal. Set IO2 as Trig in in Menu > System > I/O > IO2. When an external stimulus signal is applied to IO2, triggering conditions are met, and it is then converted to a Fiber26 trigger signal.	On: Turn on
		Off: Turn off
Trig3_in->fiber27	IO3 triggering is converted to Fiber27 trigger signal. Set IO3 as Trig in in Menu > System > I/O > IO3. When an external stimulus signal is applied to IO3, triggering conditions are met, and it is then converted to a Fiber27 trigger signal.	On: Turn on
		Off: Turn off
Trig4_in->fiber28	IO4 triggering is converted to Fiber28 trigger signal. Set IO4 as Trig in in Menu > System > I/O > IO4. When an external stimulus signal is applied to IO4, triggering conditions are met, and it is then converted to a Fiber28 trigger signal.	On: Turn on
		Off: Turn off

Parameter	Description	Setting Range
Manual->fiber29	Manual triggering is converted to Fiber29 trigger signal. Pressing the <b>[Trig]</b> key on the front panel generates triggering conditions, and it is then converted to a Fiber29 trigger signal.	On: Turn on
		Off: Turn off
GpibTrigger->fiber30	GPIB triggering signal is converted to Fiber30 trigger signal. In the Ni-VISA software, clicking Trig generates triggering conditions, and it is then converted to a Fiber30 trigger signal.	On: Turn on
		Off: Turn off
BusTrigger->fiber31	Bus triggering signal is converted to Fiber31 trigger signal. Using SCPI to send the command <b>*TRG</b> generates triggering conditions, and it is then converted to a Fiber31 trigger signal.	On: Turn on
		Off: Turn off
ScopeTrigger->fiber32	Oscilloscope triggering signal is converted to Fiber32 trigger signal. In the IT2800's Scope function, when the triggering conditions for the Scope are met, it is then converted to a Fiber32 trigger signal.	On: Turn on
		Off: Turn off

### Synchronous triggering in normal mode

1. Enter the **Menu > System > Fiber** interface and enable the required trigger functionalities.

Example of the Synchronization Trigger Interface: The Master opens Manual and converts it to Fiber29 signal.

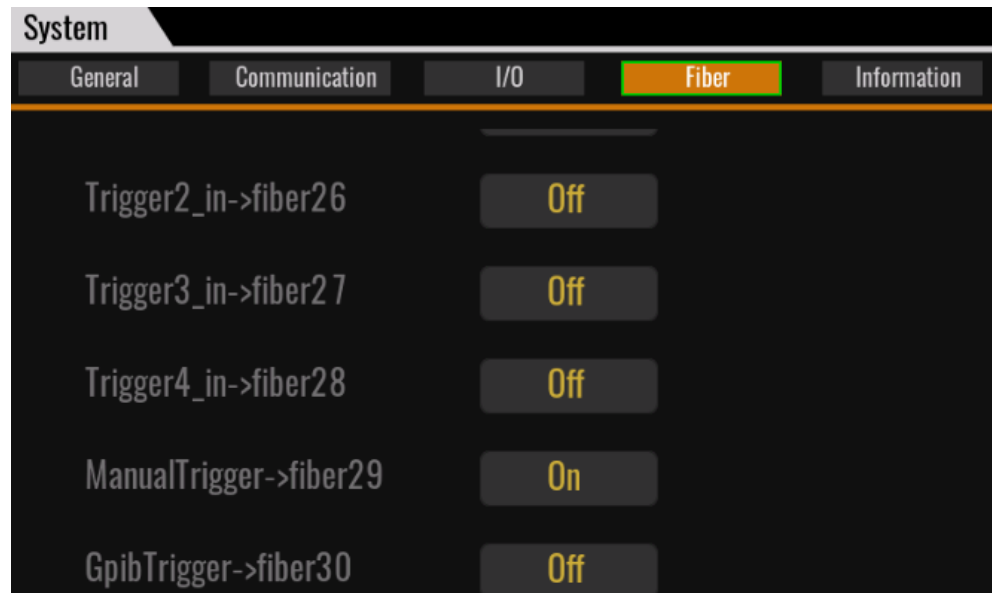

- Enter **Menu > Config > Advanced Setting > Trigger Source** and set the trigger source to **Fiber**, with available mapped fiber signals from Fiber25 to Fiber32.

Each IT2800 SMU that needs to receive trigger signals must be configured with the trigger source.

Example of Trigger Source Settings Interface: Set the trigger source for the Master as **Fiber 29**.

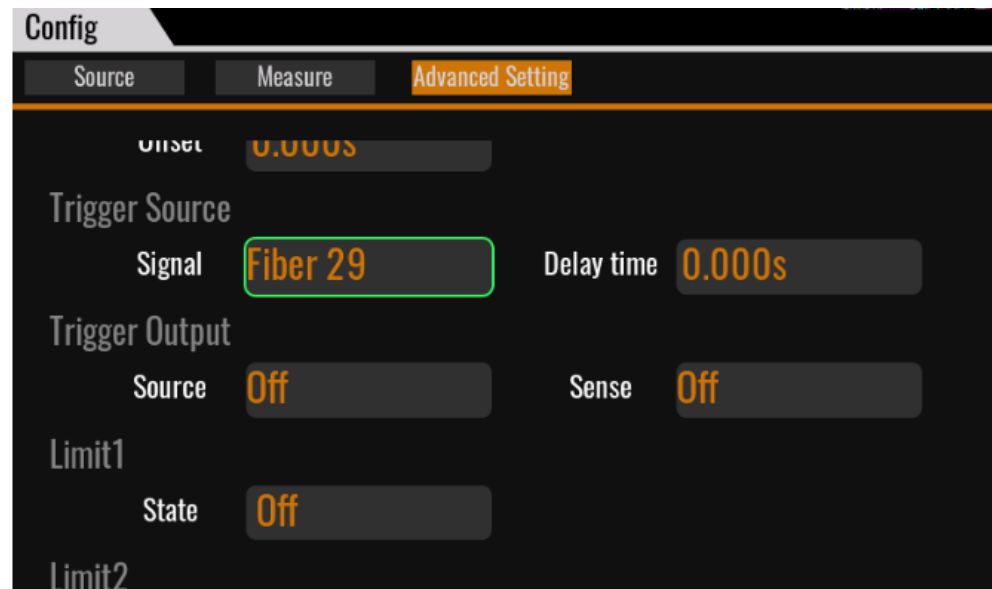

Example of Trigger Source Settings Interface: Set the trigger source for the Slave as **Fiber 29**.

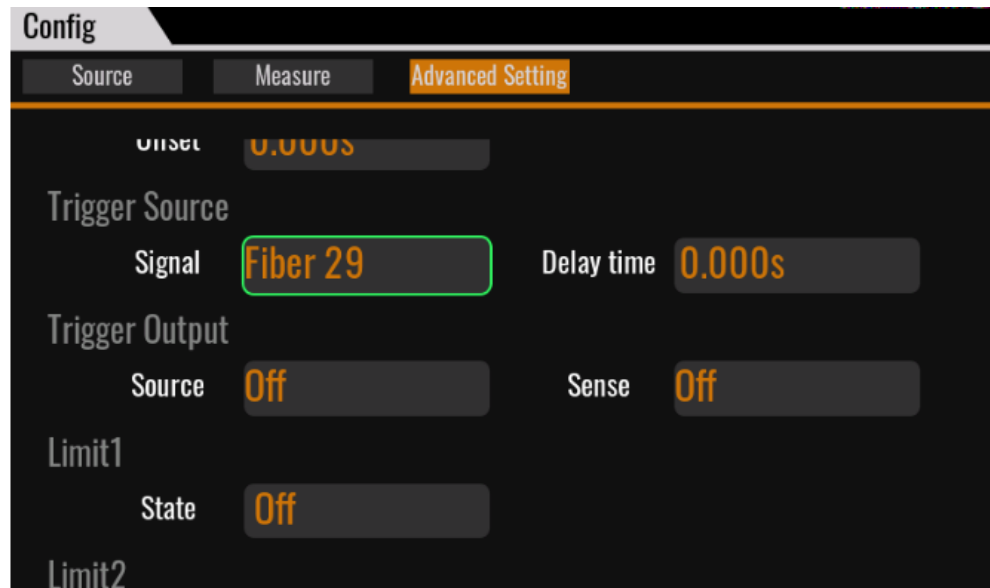

After completing the settings as described above, pressing the **[Trig]** key on the Master's front panel generates a trigger, and the trigger signal is converted to Fiber29. All synchronized IT2800 series SMU slave units will receive this signal.

### Synchronous triggering in Sweep mode

1. Enter the **Menu > System > Fiber** interface and enable the required trigger functionalities.

Example of the Synchronization Trigger Interface: The Master opens Manual and converts it to Fiber29 signal.

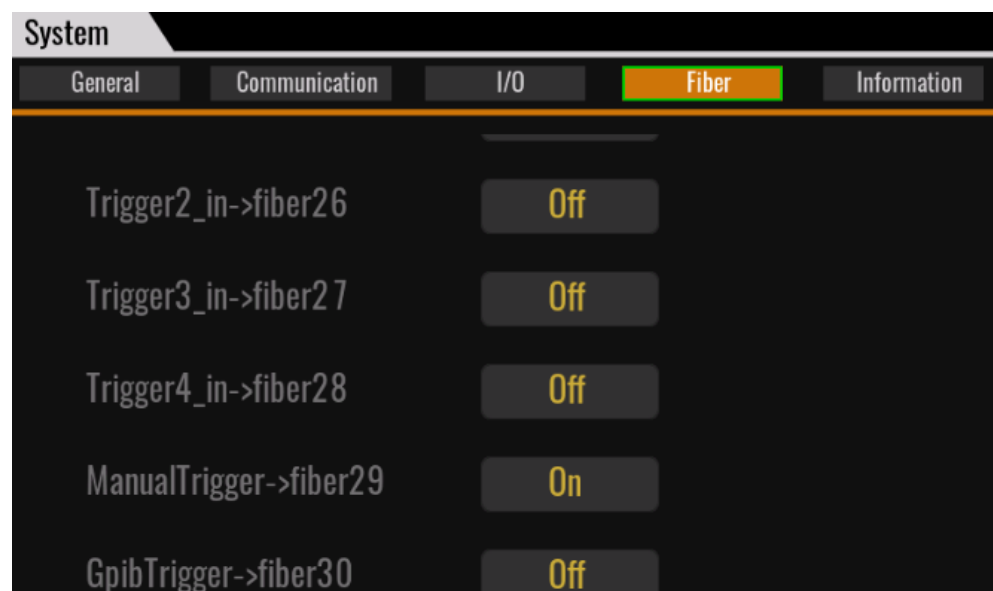

2. Enter **Menu > Sweep > Setting > Trigger Setting > Start Trig Source** and set the trigger source to **Fiber**, with available mapped fiber signals from Fiber25 to Fiber32.

Each IT2800 SMU that needs to receive trigger signals must be configured with the trigger source.

Trigger Source Settings Interface (Sweep):

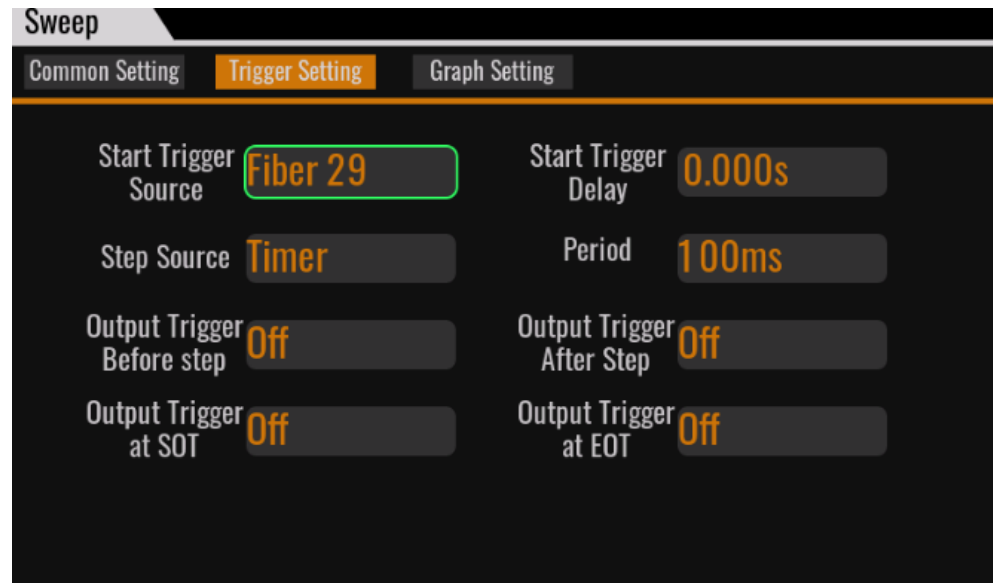

After completing the settings as described above, pressing the **[Trig]** key on the Master's front panel generates a trigger, and the trigger signal is converted to Fiber29. All synchronized IT2800 series SMU slave units will receive this signal.

After receiving the trigger signal, the Sweep operation will commence.

### Fiber Trigger without using the Fiber Remap Function

This function does not require enabling the Fiber Redirect feature in **Menu > System > Fiber**. Instead, set the trigger source signal in **Menu > Config > Advanced Setting > Trigger Source** to **Manual** and set **Menu > Config > Advanced Setting > Trigger Output** to **Fiber** (triggering output a fiber signal). This way, the device will output a fiber signal upon receiving a trigger signal (-pressing the **[Trig]** key).

1. Enter **Menu > Config > Advanced Setting** and the interface is displayed as below.

Config

Source
Measure
Advanced Setting

Offset 0.000s

Trigger Source

Signal Manual      Delay time 0.000s

Trigger Output

Source Fiber 1      Sense Off

Limit1

State Off

2. After completing the settings, pressing the **[Trig]** key on the front panel will cause the IT2800 SMU to output a fiber trigger signal upon receiving the Manual trigger signal.

# 4 Technical Specification

This chapter will introduce the main technical parameters of the instrument, such as rated voltage/current/power and so on. Besides, we will introduce the working environment and storage temperature.

- ◆ [Main Specification](#)
- ◆ [Supplemental Characteristics](#)

## 4.1 Main Specification

### 4.1.1 IT2801

#### Basic Parameters

Working temperature	0~40°C
Altitude	0~2000M
AC input voltage	90~260V
AC input frequency	50/60Hz
AC input apparent power	250VA
Cooling style	fans
External dimensions (without rubber bumper and handle)	450mm (D) x 214mm (W) x 88.2mm (H)
Weight	6.7kg
Maximum output power	20W
Maximum output voltage	1050V
Maximum output current	1.05A
Communication interface	Standard: USB and LAN Optional: GPIB

System Bus	Fiber optic
Digital I/O	DB25
Command response time	1ms

### Electrical performance parameters

Test conditions
1. Temperature: 23°C±5°C
2. Humidity: 30%~80% relative humidity
3. Use after 60 minutes for warming up the device
4. Calibration period: 1 year
5. Measuring speed: 1 PLC (power line cycle)

Voltage accuracy				
Range	Source / Measure Resolution	Setting accuracy	Measurement accuracy	Noise (peak to peak) (<10Hz)
±200mV	100nV	0.015%+300μV	0.015%+300μV	≤25μV
±2V	1μV	0.015%+300μV	0.015%+300μV	≤25μV
±20V	10μV	0.015%+1mV	0.015%+1mV	≤200μV
±200V	100μV	0.015%+10mV	0.015%+10mV	≤2mV
±1000V	1mV	0.02%+50mV	0.02%+50mV	≤10mV

Current accuracy				
Range	Source / Measure resolution	Setting accuracy	Measurement accuracy	Noise (peak to peak) (<10Hz)
±1μA	1pA	0.025%+300pA	0.025%+300pA	≤8pA
±10μA	10pA	0.025%+700pA	0.025%+700pA	≤80pA

±100μA	100pA	0.025%+6nA	0.025%+6nA	≤800pA
±1mA	1nA	0.025%+60nA	0.025%+60nA	≤8nA
±10mA	10nA	0.025%+600nA	0.025%+600nA	≤80nA
±100mA	100nA	0.025%+6μA	0.025%+6μA	≤800nA
±1A	1μA	0.03%+500μA	0.03%+500μA	≤30μA

Resistance accuracy (4-wire measurement, 2V range)				
Range	Resolu- tion	Test current	Current range	Measurement accuracy
2Ω	1μΩ	1A	1A	0.1%+300μΩ
20Ω	10μΩ	100mA	100mA	0.055%+3mΩ
200Ω	100μΩ	10mA	10mA	0.055%+30mΩ
2KΩ	1mΩ	1mA	1mA	0.055%+300mΩ
20KΩ	10mΩ	100μA	100μA	0.055%+3Ω
200KΩ	100mΩ	10μA	10μA	0.055%+30Ω
2MΩ	1Ω	1μA	1μA	0.07%+300Ω
20MΩ	10Ω	100nA	1μA	0.35%+3kΩ

Derating accuracy with PLC setting < 1 PLC (additional accuracy deviation, i.e., a percentage of the following range needs to be added to the existing accuracy deviation)						
PLC	1μA~1- 0μA	100μA~- 100mA	1A	200- mV	2V	20V~1000V
0.1PLC	0.01%	0.01%	0.02%	0.02- %	0.01- %	0.01%
0.01PLC	0.08%	0.05%	0.03%	0.05- %	0.05- %	0.02%
0.001PL- C	0.50%	0.50%	0.20%	0.20- %	0.10- %	0.05%

## Supplemental Characteristics

### Supplemental Characteristics

1. Temperature coefficient (0 to 18 °C and 28 to 50 °C):  $\pm 0.15 \times$  accuracy/°C

2. Noise 10 Hz to 20 MHz (V source): 30mV p-p, 3mV rms

3. Voltage output stabilization time.

The time required to reach within 0.1% of the final value under open circuit conditions.

Stepping from 10% to 90% of the range

200mV: < 450 $\mu$ s

2V: < 700 $\mu$ s

20V: < 250 $\mu$ s

200V: < 300 $\mu$ s

1000V: < 5ms

4. Slew rate

Stepping from 10% to 90% of the range under no-load condition.

200mV: 2mV/ $\mu$ s

2V: 20mV/ $\mu$ s

20V: 200mV/ $\mu$ s

200V: 1.8V/ $\mu$ s

1000V: 1V/ $\mu$ s

5. Current output stabilization time.

The time required to reach within 0.1% of the final value under short-circuit conditions.

Stepping from 10% to 90% of the range

1 $\mu$ A: < 1.5ms

10 $\mu$ A: < 1ms

100 $\mu$ A: < 300 $\mu$ s

1mA: < 300 $\mu$ s

10mA: < 300 $\mu$ s

100mA: < 300 $\mu$ s

1A: < 300 $\mu$ s

6. V source overshoot: <(0.1%+10mV)

Step is 10%~90% of the range, resistive load.

7. I source overshoot: <0.1%.

Step is 10%~90% of the range, resistive load.

8. Voltage source range change overshoot: <250mV. 100K load, 20 MHz bandwidth

9. Current source range change overshoot: < 250mV/R load, 20 MHz bandwidth
10. Maximum capacitive load: 0.01 $\mu$ F
11. DC floating voltage: Max  $\pm$ 250 V DC between low force and chassis ground
12. Guard offset voltage (V source): < 1mV
13. GUARD output impedance: >10K $\Omega$  Typical
14. Common mode isolation: > 1G $\Omega$ , < 4700pF
15. Max voltage between High Force and High Sense: 4V  
Max voltage between Low Force and Low Sense: 4V

## 4.1.2 IT2805

### Basic Parameters

Working temperature	0~40°C
Altitude	0~2000M
AC input voltage	90~260V
AC input frequency	50/60Hz
AC input apparent power	250VA
Cooling style	fans
External dimensions (without rubber bumper and handle)	450mm (D) x 214mm (W) x 88.2mm (H)
Weight	6.7kg
Maximum output power	20W
Maximum output voltage	210V
Maximum output current	1.515A

Communication interface	Standard: USB and LAN Optional: GPIB
System Bus	Fiber optic
Digital I/O	DB25
Command response time	1ms

### Electrical performance parameters

Test conditions
1. Temperature: 23°C±5°C
2. Humidity: 30%~80% relative humidity
3. Use after 60 minutes for warming up the device
4. Calibration period: 1 year
5. Measuring speed: 1 PLC (power line cycle)

Voltage and Current		
	Voltage	Current
DC and Pulse	200V	0.1A
	20V	1A
	6V	1.5A

Voltage accuracy					
Range	Setting resolution	Setting accuracy	Measurement resolution	Measurement accuracy	Noise (-peak to peak) (<10Hz)
±200mV	1μV	0.015% +300μV	100nV	0.015% +300μV	≤ 8 μV

±2V	10μV	0.015% +300μV	1μV	0.015% +300μV	≤ 10 μV
±20V	100μV	0.015%+1mV	10μV	0.015%+1mV	≤ 80 μV
±200V	1mV	0.015%+10mV	100μV	0.015% +10mV	≤ 800μV

Current accuracy					
Range	Setting resolution	Setting accuracy	Measurement resolution	Measurement accuracy	Noise (peak to peak) (<10Hz)
±10nA	100fA	0.1%+50pA	10fA	0.1%+50pA	≤ 2pA
±100nA	1pA	0.06% +100pA	100fA	0.06% +100pA	≤ 3 pA
±1μA	10pA	0.025% +300pA	1pA	0.025% +300pA	≤ 10 pA
±10μA	100pA	0.025% +700pA	10pA	0.025% +700pA	≤ 60 pA
±100μA	1nA	0.02%+6nA	100pA	0.02%+6nA	≤ 600pA
±1mA	10nA	0.02%+60nA	1nA	0.02% +60nA	≤ 6nA
±10mA	100nA	0.02% +600nA	10nA	0.02% +600nA	≤ 60 nA
±100mA	1μA	0.02%+6μA	100nA	0.02%+6μA	≤ 600 nA
±1A	10μA	0.05% +500μA	1μA	0.05% +500μA	≤ 10μA
±1.5A	10μA	0.05% +1.5mA	1μA	0.05% +1.5mA	≤ 30μA

Resistance accuracy (4-wire measurement, 2V range)				
Range	Resolution	Test current	Current range	Measurement accuracy

2Ω	1μΩ	1A	1A	0.1%+300μΩ
20Ω	10μΩ	100mA	100mA	0.055%+3mΩ
200Ω	100μΩ	10mA	10mA	0.055%+30mΩ
2KΩ	1mΩ	1mA	1mA	0.055%+300mΩ
20KΩ	10mΩ	100μA	100μA	0.055%+3Ω
200KΩ	100mΩ	10μA	10μA	0.055%+30Ω
2MΩ	1Ω	1μA	1μA	0.07%+300Ω
20MΩ	10Ω	100nA	100nA	0.2%+3kΩ
200MΩ	100Ω	10nA	10nA	0.7%+30kΩ

Derating accuracy with PLC setting < 1 PLC (additional accuracy deviation, i.e., a percentage of the following range needs to be added to the existing accuracy deviation)		
PLC	200mV	2V~200V
0.1PLC	0.01%	0.005%
0.01PLC	0.05%	0.01%
0.001PLC	0.3%	0.10%

PLC	10nA	100nA	1μA~10μA	100μA~100mA	1A-1.5A
0.1PLC	0.30%	0.03%	0.01%	0.01%	0.01%
0.01PLC	1.00%	0.10%	0.05%	0.02%	0.03%
0.001PLC	3.00%	1.00%	0.30%	0.20%	0.20%

## Supplemental Characteristics

### Supplemental Characteristics

1. Temperature coefficient (0 to 18 °C and 28 to 50 °C): ±0.15 x accuracy/°C

2. Noise 10 Hz to 20 MHz (V source): 30mVp-p / 4mVrms (1A range and below)

3. Voltage output stabilization time.

The time required to reach within 0.1% of the final value under open circuit conditions.

Stepping from 10% to 90% of the range

200mV: < 100 $\mu$ s (1.5A range)

2V: < 120 $\mu$ s (1.5A range)

20V: < 250 $\mu$ s (1A range)

200V: < 400 $\mu$ s (100mA range)

4. Slew rate

Stepping from 10% to 90% of the range under no-load condition.

200mV: 3mV/ $\mu$ s (3A range)

2V: 24mV/ $\mu$ s (3A range)

20V: 140mV/ $\mu$ s (1A range)

200V: 0.6V/ $\mu$ s (100mA range)

5. Current output stabilization time.

The time required to reach within 0.1% of the final value under short-circuit conditions.

Stepping from 10% to 90% of the range

100nA: < 5ms

1 $\mu$ A: < 600 $\mu$ s

10 $\mu$ A: < 350 $\mu$ s

100 $\mu$ A: < 200 $\mu$ s

1mA: < 150 $\mu$ s

10mA: < 150 $\mu$ s

100mA: < 150 $\mu$ s

1A: < 300 $\mu$ s

1.5A: < 100 $\mu$ s

6. V source overshoot: < (0.1%+10mV)

Step is 10%~90% of the range, resistive load.

7. I source overshoot: < 0.1%

Step is 10%~90% of the range, resistive load.

8. Voltage source range change overshoot: < 250mV. 100K load, 20 MHz bandwidth

9. Current source range change overshoot: < 250mV/R load, 20 MHz bandwidth

10. Maximum capacitive load: 0.01 $\mu$ F (Normal mode), 50 $\mu$ F (High capacitance mode)

11. DC floating voltage: Max  $\pm 250$  V DC between low force and chassis ground
12. Guard offset voltage (V source):  $< 1$  mV
13. GUARD output impedance:  $> 10$  k $\Omega$  Typical
14. Common mode isolation:  $> 1$  G $\Omega$ ,  $< 4700$  pF
15. Max voltage between High Force and High Sense: 4V  
Max voltage between Low Force and Low Sense: 4V

### Pulse source supplemental characteristics

Minimum programmable pulse width: 100 $\mu$ s

Pulse width programming resolution: 10 $\mu$ s

	Max voltage	Max peak current	Max base current	Max pulse width	Max duty cycle
DC or pulsed	6V	1.5A	1.5A	Unlimited	100%
	20	1A	1A	Unlimited	100%
	200	0.1A	0.1A	Unlimited	100%

## 4.1.3 IT2806

### Basic Parameters

Working temperature	0~40 $^{\circ}$ C
Altitude	0~2000M
AC input voltage	90~260V
AC input frequency	50/60Hz
AC input apparent power	250VA
Cooling style	fans

External dimensions (without rubber bumper and handle)	450mm (D) x 214mm (W) x 88.2mm (H)
Weight	6.7kg
Maximum output power	20W
Maximum output voltage	210V
Maximum output current	3.03A DC / 10.5A Pulse
Communication interface	Standard: USB and LAN Optional: GPIB
System Bus	Fiber optic
Digital I/O	DB25
Command response time	1ms

### Electrical performance parameters

Test conditions
1. Temperature: 23°C±5°C
2. Humidity: 30%~80% relative humidity
3. Use after 60 minutes for warming up the device
4. Calibration period: 1 year
5. Measuring speed: 1 PLC (power line cycle)

Voltage and Current		
	Voltage	Current
DC and Pulse	200V	0.1A
	20V	1A
	6V	3A

Pulse	200V	1A
	12V	10A

Voltage accuracy				
Range	Resolution	Setting accuracy	Measurement accuracy	Noise (peak to peak) (<10Hz)
±200mV	100nV	0.015%+300μV	0.015%+300μV	≤ 8μV
±2V	1μV	0.015%+300μV	0.015%+300μV	≤ 10μV
±20V	10μV	0.015%+1mV	0.015%+1mV	≤ 80μV
±200V	100μV	0.015%+10mV	0.015%+10mV	≤ 800μV

Current accuracy				
Range	Source / Measure resolution	Setting accuracy	Measurement accuracy	Noise (peak to peak) (<10Hz)
±10nA	10fA	0.1%+50pA	0.1%+50pA	≤ 2pA
±100nA	100fA	0.06%+100pA	0.06%+100pA	≤ 3 pA
±1μA	1pA	0.025%+300pA	0.025%+300pA	≤ 10 pA
±10μA	10pA	0.025%+700pA	0.025%+700pA	≤ 60 pA
±100μA	100pA	0.02%+6nA	0.02%+6nA	≤ 600pA
±1mA	1nA	0.02%+60nA	0.02%+60nA	≤ 6nA
±10mA	10nA	0.02%+600nA	0.02%+600nA	≤ 60 nA
±100mA	100nA	0.02%+6μA	0.02%+6μA	≤ 600 nA
±1A	1μA	0.05%+500μA	0.05%+500μA	≤ 10μA
±3A	10μA	0.05%+1.5mA	0.05%+1.5mA	≤ 30μA
±10A (*1)	10μA	0.4%+25mA (*2)	0.4%+25mA (*2)	-

\*1 Pulse mode

\*2 Measurement speed: 0.01 PLC

Resistance accuracy (4-wire measurement, 2V range)				
Range	Resolu- tion	Test current	Current range	Measurement accuracy
2Ω	1μΩ	1A	1A	0.1%+300μΩ
20Ω	10μΩ	100mA	100mA	0.055%+3mΩ
200Ω	100μΩ	10mA	10mA	0.055%+30mΩ
2KΩ	1mΩ	1mA	1mA	0.055%+300mΩ
20KΩ	10mΩ	100μA	100μA	0.055%+3Ω
200KΩ	100mΩ	10μA	10μA	0.055%+30Ω
2MΩ	1Ω	1μA	1μA	0.07%+300Ω
20MΩ	10Ω	100nA	100nA	0.2%+3kΩ
200MΩ	100Ω	10nA	10nA	0.7%+30kΩ

Derating accuracy with PLC setting < 1 PLC (- additional accuracy deviation, i.e., a percentage of the following range needs to be added to the existing accuracy deviation)		
PLC	200mV	2V-200V
0.1PLC	0.01%	0.005%
0.01PLC	0.05%	0.01%
0.001PLC	0.3%	0.1%

PLC	10nA	100nA	1μA~10μA	100μA~100m- A	1A~3A
0.1PLC	0.30%	0.03%	0.01%	0.01%	0.01%

0.01PLC	1.00%	0.10%	0.05%	0.02%	0.03%
0.001PL-C	3.00%	1.00%	0.30%	0.20%	0.20%

## Supplemental Characteristics

1. Temperature coefficient (0 to 18 °C and 28 to 50 °C):  $\pm 0.15 \times$  accuracy/°C
2. Noise 10 Hz to 20 MHz (V source): 30mVp-p / 4mVrms (1A range and below)
3. Voltage output stabilization time.  
The time required to reach within 0.1% of the final value under open circuit conditions.  
Stepping from 10% to 90% of the range  
200mV: < 100 $\mu$ s (3A range)  
2V: < 120 $\mu$ s (3A range)  
20V: < 250 $\mu$ s (1A range)  
200V: < 400 $\mu$ s (100mA range)
4. Slew rate  
Stepping from 10% to 90% of the range under no-load condition.  
200mV: 3mV/ $\mu$ s (3A range)  
2V: 24mV/ $\mu$ s (3A range)  
20V: 140mV/ $\mu$ s (1A range)  
200V: 0.6V/ $\mu$ s (100mA range)
5. Current output stabilization time.  
The time required to reach within 0.1% of the final value under short-circuit conditions.  
Stepping from 10% to 90% of the range  
100nA: < 5ms  
1 $\mu$ A: < 600 $\mu$ s  
10 $\mu$ A: < 350 $\mu$ s  
100 $\mu$ A: < 200 $\mu$ s  
1mA: < 150 $\mu$ s  
10mA: < 150 $\mu$ s  
100mA: < 150 $\mu$ s  
1A: < 300 $\mu$ s  
3A: < 80 $\mu$ s
6. V source overshoot: < (0.1%+10mV)

Step is 10%~90% of the range, resistive load.

7. I source overshoot: < 0.1%

Step is 10%~90% of the range, resistive load.

8. Voltage source range change overshoot: < 250mV. 100K load, 20 MHz bandwidth

9. Current source range change overshoot: < 250mV/R load, 20 MHz bandwidth

10. Maximum capacitive load: 0.01 $\mu$ F (Normal mode), 50 $\mu$ F (High capacitance mode)

11. DC floating voltage: Max  $\pm$ 250 V DC between low force and chassis ground

12. Guard offset voltage (V source): < 1mV

13. GUARD output impedance: > 10K $\Omega$  Typical

14. Common mode isolation: > 1G $\Omega$ , < 4700pF

15. Max voltage between High Force and High Sense: 4V  
Max voltage between Low Force and Low Sense: 4V

### Pulse source supplemental characteristics

Minimum programmable pulse width: 100 $\mu$ s

Pulse width programming resolution: 10 $\mu$ s

	Max voltage	Max peak current	Max base current	Max pulse width	Max duty cycle
DC or pulsed	6V	3A	3A	Unlimited	100%
	20	1A	1A	Unlimited	100%
	200	0.1A	0.1A	Unlimited	100%
Pulse	12V	10A	0.5A	1ms	2.50%
	200	1A	50mA	2.5ms	2.50%

## 4.1.4 IT2801R

### Basic Parameters

Working temperature	0~40°C
Altitude	0~2000M
AC input voltage	90~260V
AC input frequency	50/60Hz
AC input apparent power	250VA
Cooling style	fans
External dimensions (without rubber bumper and handle)	450mm (D) x 214mm (W) x 88.2mm (H)
Weight	6.7kg
Maximum output power	20W
Maximum output voltage	1050V
Maximum output current	1.05A
Communication interface	USB/LAN
System Bus	Fiber optic
Digital I/O	DB25
Command response time	1ms

### Electrical performance parameters

Test conditions
1. Temperature: 23°C±5°C
2. Humidity: 30%~80% relative humidity

3. Use after 60 minutes for warming up the device
4. Calibration period: 1 year
5. Measuring speed: 1 PLC (power line cycle)

Voltage accuracy				
Range	Source / Measure Resolution	Setting accuracy	Measurement accuracy	Noise (peak to peak) (<10Hz)
±200mV	100nV	0.015%+300μV	0.015%+300μV	≤25μV
±2V	1μV	0.015%+300μV	0.015%+300μV	≤25μV
±20V	10μV	0.015%+1mV	0.015%+1mV	≤200μV
±200V	100μV	0.015%+10mV	0.015%+10mV	≤2mV
±1000V	1mV	0.02%+50mV	0.02%+50mV	≤10mV

Current accuracy				
Range	Source / Measure resolution	Setting accuracy	Measurement accuracy	Noise (peak to peak) (<10Hz)
±1μA	1pA	0.025%+300pA	0.025%+300pA	≤8pA
±10μA	10pA	0.025%+700pA	0.025%+700pA	≤80pA
±100μA	100pA	0.025%+6nA	0.025%+6nA	≤800pA
±1mA	1nA	0.025%+60nA	0.025%+60nA	≤8nA
±10mA	10nA	0.025%+600nA	0.025%+600nA	≤80nA
±100mA	100nA	0.025%+6μA	0.025%+6μA	≤800nA
±1A	1μA	0.03%+500μA	0.03%+500μA	≤30μA

Resistance accuracy (4-wire measurement, 2V range)				
Range	Resolution	Test current	Current range	Measurement accuracy

2Ω	1μΩ	1A	1A	0.1%+300μΩ
20Ω	10μΩ	100mA	100mA	0.055%+3mΩ
200Ω	100μΩ	10mA	10mA	0.055%+30mΩ
2KΩ	1mΩ	1mA	1mA	0.055%+300mΩ
20KΩ	10mΩ	100μA	100μA	0.055%+3Ω
200KΩ	100mΩ	10μA	10μA	0.055%+30Ω
2MΩ	1Ω	1μA	1μA	0.07%+300Ω
20MΩ	10Ω	100nA	1μA	0.35%+3kΩ

Derating accuracy with PLC setting < 1 PLC (additional accuracy deviation, i.e., a percentage of the following range needs to be added to the existing accuracy deviation)						
PLC	1μA~1-0μA	100μA~-100mA	1A	200-mV	2V	20V~1000V
0.1PLC	0.01%	0.01%	0.02%	0.02-%	0.01-%	0.01%
0.01PLC	0.08%	0.05%	0.03%	0.05-%	0.05-%	0.02%
0.001PL-C	0.50%	0.50%	0.20%	0.20-%	0.10-%	0.05%

## Supplemental Characteristics

### Supplemental Characteristics

1. Temperature coefficient (0 to 18 °C and 28 to 50 °C):  $\pm 0.15 \times$  accuracy/°C
2. Noise 10 Hz to 20 MHz: 4mVrms
3. Voltage output stabilization time.  
The time required to reach within 0.1% of the final value under open circuit conditions.  
Stepping from 10% to 90% of the range  
200mV: < 450μs  
2V: < 700μs

20V: < 250 $\mu$ s

200V: < 300 $\mu$ s

1000V: < 5ms

#### 4. Slew rate

Stepping from 10% to 90% of the range under no-load condition.

200mV: 2mV/ $\mu$ s

2V: 20mV/ $\mu$ s

20V: 200mV/ $\mu$ s

200V: 1.8V/ $\mu$ s

1000V: 1V/ $\mu$ s

#### 5. Current output stabilization time.

The time required to reach within 0.1% of the final value under short-circuit conditions.

Stepping from 10% to 90% of the range

1 $\mu$ A: < 1.5ms

10 $\mu$ A: < 1ms

100 $\mu$ A: < 300 $\mu$ s

1mA: < 300 $\mu$ s

10mA: < 300 $\mu$ s

100mA: < 300 $\mu$ s

1A: < 300 $\mu$ s

#### 6. V source overshoot: <(0.1%+10mV)

Step is 10%~90% of the range, resistive load.

#### 7. I source overshoot: <0.1%.

Step is 10%~90% of the range, resistive load.

#### 8. Voltage source range change overshoot: <250mV. 100K load, 20 MHz bandwidth

#### 9. Current source range change overshoot: < 250mV/R load, 20 MHz bandwidth

#### 10. Maximum capacitive load: 0.01 $\mu$ F

#### 11. DC floating voltage: Max $\pm$ 250 V DC between low force and chassis ground

#### 12. Guard offset voltage (V source): < 1mV

#### 13. GUARD output impedance: >10k $\Omega$ Typical

#### 14. Common mode isolation: > 1G $\Omega$ , < 4700pF

#### 15. Max voltage between High Force and High Sense: 4V

Max voltage between Low Force and Low Sense: 4V

## 4.1.5 IT2805R

### Basic Parameters

Working temperature	0~40°C
Altitude	0~2000M
AC input voltage	90~260V
AC input frequency	50/60Hz
AC input apparent power	250VA
Cooling style	fans
External dimensions (without rubber bumper and handle)	450mm (D) x 214mm (W) x 88.2mm (H)
Weight	6.7kg
Maximum output power	20W
Maximum output voltage	210V
Maximum output current	1.515A
Communication interface	USB/LAN
System Bus	Fiber optic
Digital I/O	DB25
Command response time	1ms

**Electrical performance parameters**

Test conditions
1. Temperature: 23°C±5°C
2. Humidity: 30%~80% relative humidity
3. Use after 60 minutes for warming up the device
4. Calibration period: 1 year
5. Measuring speed: 1 PLC (power line cycle)

Voltage and Current		
	Voltage	Current
DC and Pulse	200V	0.1A
	20V	1A
	6V	1.5A

Voltage accuracy					
Range	Setting resolution	Setting accuracy	Measurement resolution	Measurement accuracy	Noise (-peak to peak) (<10Hz)
±200mV	1μV	0.015%+300μV	100nV	0.015%+300μV	≤ 8 μV
±2V	10μV	0.015%+300μV	1μV	0.015%+300μV	≤ 10 μV
±20V	100μV	0.015%+1mV	10μV	0.015%+1mV	≤ 80 μV
±200V	1mV	0.015%+10mV	100μV	0.015%+10mV	≤ 800μV

Current accuracy					
Range	Setting resolution	Setting accuracy	Measurement resolution	Measurement accuracy	Noise (peak to peak) (<10Hz)
±10nA	100fA	0.1%+50pA	10fA	0.1%+50pA	≤ 2pA
±100nA	1pA	0.06%+100pA	100fA	0.06%+100pA	≤ 3 pA
±1μA	10pA	0.025%+300pA	1pA	0.025%+300pA	≤ 10 pA
±10μA	100pA	0.025%+700pA	10pA	0.025%+700pA	≤ 60 pA
±100μA	1nA	0.02%+6nA	100pA	0.02%+6nA	≤ 600pA
±1mA	10nA	0.02%+60nA	1nA	0.02%+60nA	≤ 6nA
±10mA	100nA	0.02%+600nA	10nA	0.02%+600nA	≤ 60 nA
±100mA	1μA	0.02%+6μA	100nA	0.02%+6μA	≤ 600 nA
±1A	10μA	0.05%+500μA	1μA	0.05%+500μA	≤ 10μA
±1.5A	10μA	0.05%+1.5mA	1μA	0.05%+1.5mA	≤ 30μA

Resistance accuracy (4-wire measurement, 2V range)				
Range	Resolution	Test current	Current range	Measurement accuracy
2Ω	1μΩ	1A	1A	0.1%+300μΩ
20Ω	10μΩ	100mA	100mA	0.055%+3mΩ
200Ω	100μΩ	10mA	10mA	0.055%+30mΩ
2KΩ	1mΩ	1mA	1mA	0.055%+300mΩ
20KΩ	10mΩ	100μA	100μA	0.055%+3Ω
200KΩ	100mΩ	10μA	10μA	0.055%+30Ω

2MΩ	1Ω	1μA	1μA	0.07%+300Ω
20MΩ	10Ω	100nA	100nA	0.2%+3kΩ
200MΩ	100Ω	10nA	10nA	0.7%+30kΩ

Derating accuracy with PLC setting < 1 PLC (additional accuracy deviation, i.e., a percentage of the following range needs to be added to the existing accuracy deviation)		
PLC	200mV	2V~200V
0.1PLC	0.01%	0.005%
0.01PLC	0.05%	0.01%
0.001PLC	0.3%	0.10%

PLC	10nA	100nA	1μA~10μA	100μA~100mA	1A-1.5A
0.1PLC	0.30%	0.03%	0.01%	0.01%	0.01%
0.01PLC	1.00%	0.10%	0.05%	0.02%	0.03%
0.001PLC	3.00%	1.00%	0.30%	0.20%	0.20%

## Supplemental Characteristics

### Supplemental Characteristics

1. Temperature coefficient (0 to 18 °C and 28 to 50 °C):  $\pm 0.15 \times$  accuracy/°C

2. Noise 10 Hz to 20 MHz (V source): 4mVrms (1A range and below)

3. Voltage output stabilization time.

The time required to reach within 0.1% of the final value under open circuit conditions.

Stepping from 10% to 90% of the range

200mV: < 100μs (1.5A range)

2V: < 120μs (1.5A range)

20V: < 250μs (1A range)

200V: < 400 $\mu$ s (100mA range)

4. Slew rate

Stepping from 10% to 90% of the range under no-load condition.

200mV: 3mV/ $\mu$ s (3A range)

2V: 24mV/ $\mu$ s (3A range)

20V: 140mV/ $\mu$ s (1A range)

200V: 0.6V/ $\mu$ s (100mA range)

5. Current output stabilization time.

The time required to reach within 0.1% of the final value under short-circuit conditions.

Stepping from 10% to 90% of the range

100nA: <5ms

1 $\mu$ A: < 600 $\mu$ s

10 $\mu$ A: < 350 $\mu$ s

100 $\mu$ A: < 200 $\mu$ s

1mA: < 150 $\mu$ s

10mA: < 150 $\mu$ s

100mA: < 150 $\mu$ s

1A: < 300 $\mu$ s

1.5A: <100 $\mu$ s

6. V source overshoot: < (0.1%+10mV)

Step is 10%~90% of the range, resistive load.

7. I source overshoot: < 0.1%

Step is 10%~90% of the range, resistive load.

8. Voltage source range change overshoot: < 250mV. 100K load, 20 MHz bandwidth

9. Current source range change overshoot: < 250mV/R load, 20 MHz bandwidth

10. Maximum capacitive load: 0.01 $\mu$ F (Normal mode), 50 $\mu$ F (High capacitance mode)

11. DC floating voltage: Max  $\pm$ 250 V DC between low force and chassis ground

12. Guard offset voltage (V source): < 1mV

13. GUARD output impedance: > 10k $\Omega$  Typical

14. Common mode isolation: > 1G $\Omega$ , < 4700pF

15. Max voltage between High Force and High Sense: 4V

Max voltage between Low Force and Low Sense: 4V

### Pulse source supplemental characteristics

Minimum programmable pulse width: 100 $\mu$ s

Pulse width programming resolution: 10 $\mu$ s

	Max voltage	Max peak current	Max base current	Max pulse width	Max duty cycle
DC or pulsed	6V	1.5A	1.5A	Unlimited	100%
	20	1A	1A	Unlimited	100%
	200	0.1A	0.1A	Unlimited	100%

## 4.1.6 IT2806R

### Basic Parameters

Working temperature	0~40°C
Altitude	0~2000M
AC input voltage	90~260V
AC input frequency	50/60Hz
AC input apparent power	250VA
Cooling style	fans
External dimensions (without rubber bumper and handle)	450mm (D) x 214mm (W) x 88.2mm (H)
Weight	6.7kg
Maximum output power	20W
Maximum output voltage	210V

Maximum output current	3.03A DC / 10.5A Pulse
Communication interface	USB/LAN
System Bus	Fiber optic
Digital I/O	DB25
Command response time	1ms

### Electrical performance parameters

Test conditions
1. Temperature: 23°C±5°C
2. Humidity: 30%~80% relative humidity
3. Use after 60 minutes for warming up the device
4. Calibration period: 1 year
5. Measuring speed: 1 PLC (power line cycle)

Voltage and Current		
	Voltage	Current
DC and Pulse	200V	0.1A
	20V	1A
	6V	3A
Pulse	200V	1A
	12V	10A

Voltage accuracy				
Range	Resolution	Setting accuracy	Measurement accuracy	Noise (peak to peak) (<10Hz)
±200mV	100nV	0.015%+300μV	0.015%+300μV	≤ 8μV

±2V	1μV	0.015%+300μV	0.015%+300μV	≤ 10μV
±20V	10μV	0.015%+1mV	0.015%+1mV	≤ 80μV
±200V	100μV	0.015%+10mV	0.015%+10mV	≤ 800μV

Current accuracy				
Range	Source / Measure resolution	Setting accuracy	Measurement accuracy	Noise (peak to peak) (<10Hz)
±10nA	10fA	0.1%+50pA	0.1%+50pA	≤ 2pA
±100nA	100fA	0.06%+100pA	0.06%+100pA	≤ 3 pA
±1μA	1pA	0.025%+300pA	0.025%+300pA	≤ 10 pA
±10μA	10pA	0.025%+700pA	0.025%+700pA	≤ 60 pA
±100μA	100pA	0.02%+6nA	0.02%+6nA	≤ 600pA
±1mA	1nA	0.02%+60nA	0.02%+60nA	≤ 6nA
±10mA	10nA	0.02%+600nA	0.02%+600nA	≤ 60 nA
±100mA	100nA	0.02%+6μA	0.02%+6μA	≤ 600 nA
±1A	1μA	0.05%+500μA	0.05%+500μA	≤ 10μA
±3A	10μA	0.05%+1.5mA	0.05%+1.5mA	≤ 30μA
±10A (*1)	10μA	0.4%+25mA (*2)	0.4%+25mA (*2)	-

\*1 Pulse mode

\*2 Measurement speed: 0.01 PLC

Resistance accuracy (4-wire measurement, 2V range)				
Range	Resolu- tion	Test current	Current range	Measurement accuracy
2Ω	1μΩ	1A	1A	0.1%+300μΩ

20Ω	10μΩ	100mA	100mA	0.055%+3mΩ
200Ω	100μΩ	10mA	10mA	0.055%+30mΩ
2KΩ	1mΩ	1mA	1mA	0.055%+300mΩ
20KΩ	10mΩ	100μA	100μA	0.055%+3Ω
200KΩ	100mΩ	10μA	10μA	0.055%+30Ω
2MΩ	1Ω	1μA	1μA	0.07%+300Ω
20MΩ	10Ω	100nA	100nA	0.2%+3kΩ
200MΩ	100Ω	10nA	10nA	0.7%+30kΩ

Derating accuracy with PLC setting < 1 PLC (- additional accuracy deviation, i.e., a percentage of the following range needs to be added to the existing accuracy deviation)		
PLC	200mV	2V-200V
0.1PLC	0.01%	0.005%
0.01PLC	0.05%	0.01%
0.001PLC	0.3%	0.1%

PLC	10nA	100nA	1μA~10μA	100μA~100mA	1A~3A
0.1PLC	0.30%	0.03%	0.01%	0.01%	0.01%
0.01PLC	1.00%	0.10%	0.05%	0.02%	0.03%
0.001PLC	3.00%	1.00%	0.30%	0.20%	0.20%

### Supplemental Characteristics

1. Temperature coefficient (0 to 18 °C and 28 to 50 °C):  $\pm 0.15 \times$  accuracy/°C
2. Noise 10 Hz to 20 MHz (V source): 4mVrms (1A range and below)

3. Voltage output stabilization time.

The time required to reach within 0.1% of the final value under open circuit conditions.

Stepping from 10% to 90% of the range

200mV: < 100 $\mu$ s (3A range)

2V: < 120 $\mu$ s (3A range)

20V: < 250 $\mu$ s (1A range)

200V: < 400 $\mu$ s (100mA range)

4. Slew rate

Stepping from 10% to 90% of the range under no-load condition.

200mV: 3mV/ $\mu$ s (3A range)

2V: 24mV/ $\mu$ s (3A range)

20V: 140mV/ $\mu$ s (1A range)

200V: 0.6V/ $\mu$ s (100mA range)

5. Current output stabilization time.

The time required to reach within 0.1% of the final value under short-circuit conditions.

Stepping from 10% to 90% of the range

100nA: < 5ms

1 $\mu$ A: < 600 $\mu$ s

10 $\mu$ A: < 350 $\mu$ s

100 $\mu$ A: < 200 $\mu$ s

1mA: < 150 $\mu$ s

10mA: < 150 $\mu$ s

100mA: < 150 $\mu$ s

1A: < 300 $\mu$ s

3A: < 80 $\mu$ s

6. V source overshoot: < (0.1%+10mV)

Step is 10%~90% of the range, resistive load.

7. I source overshoot: < 0.1%

Step is 10%~90% of the range, resistive load.

8. Voltage source range change overshoot: < 250mV. 100K load, 20 MHz bandwidth

9. Current source range change overshoot: < 250mV/R load, 20 MHz bandwidth

10. Maximum capacitive load: 0.01 $\mu$ F (Normal mode), 50 $\mu$ F (High capacitance mode)

11. DC floating voltage: Max  $\pm$ 250 V DC between low force and chassis ground

---

12. Guard offset voltage (V source): < 1mV
13. GUARD output impedance: > 10kΩ Typical
14. Common mode isolation: > 1GΩ, < 4700pF
15. Max voltage between High Force and High Sense: 4V  
Max voltage between Low Force and Low Sense: 4V

### Pulse source supplemental characteristics

Minimum programmable pulse width: 100μs

Pulse width programming resolution: 10μs

	Max voltage	Max peak current	Max base current	Max pulse width	Max duty cycle
DC or pulsed	6V	3A	3A	Unlimited	100%
	20	1A	1A	Unlimited	100%
	200	0.1A	0.1A	Unlimited	100%
Pulse	12V	10A	0.5A	1ms	2.50%
	200	1A	50mA	2.5ms	2.50%

## 4.2 Supplemental Characteristics

State storage capacity: 10 sets

Recommended calibration frequency: once a year

Cooling style: fans

# 5 Routine Maintenance

This chapter describes the general maintenance items and maintenance methods of the IT2800 series SMU.

- ◆ Instrument Self-Test
- ◆ Cleaning and Maintenance
- ◆ Contact of ITECH Engineers
- ◆ Return for Repair

## 5.1 Instrument Self-Test

IT2800 series SMU provides the self-test function to check the operation. The self-test is automatically performed when the instrument is powered on. It is recommended to perform the self-test for the following condition or purpose. Before performing the self-test, turn the channel output off and disconnect test leads and cables from the terminals.

- If a channel is in the lock condition due to over temperature

In this condition, the Emergency dialog box is displayed on the screen. And the ERR indicator turns on and the **[On/Off]** switch is not effective. Perform the self-test to unlock the channel. The channel can be used soon if the self-test does not report any problem.

- If you feel that the instrument may be defective
- For preventive maintenance

## 5.2 Cleaning and Maintenance

To ensure the safety function and performance of the instrument, please clean and maintain the instrument properly.

### WARNING

- **To prevent electrical shock, disconnect the instrument from AC mains power and disconnect all test leads before cleaning.**
  - **Do not use detergent or solvents.**
  - **Do not disassemble the instrument and attempt to clean internally.**
-

Clean the outside and the front panel screen of the instrument using a soft, lintfree, cloth slightly dampened with water. Use a brush to clean the dust on the vent and cooling fans.

## 5.3 Contact of ITECH Engineers

This section describes operations to be carried out by the user in case of failure of the instrument.

### Preparation before contact

When the instrument fails, you should make the following preparations before returning the instrument to ITECH for repair or contacting engineers.

- Check all the items listed in the [Self-inspection of equipment faults](#) and confirm whether there are still some problems.
- Collect the SN of the instrument.  
For details, see [Collect the SN number](#).

If there are still some problems, carefully read the **Warranty** and **Limitation of Warranty** in the preface of the manual. Confirm that your instrument complies with warranty service conditions. If after your warranty expires, ITECH offers repair services at competitive prices.

### Self-inspection of equipment faults

When the instrument fails, make the following checks to ensure that the failure is in the instrument rather than any external connections. If the instrument failure can be eliminated via simple inspection, the maintenance cost and time can be saved.

- Check whether the AC power cord is securely connected to the instrument and to a powered outlet.
- Check whether the front-panel Power On switch has been pushed.
- Check whether self-inspection of the instrument is successful and whether the specifications and performance are within the indicator ranges.
- Check whether the instrument displays error information.
- Use other instruments instead of this instrument for confirmation.

### Collect the SN number

ITECH will constantly improve the product performance, availability and reliability. All relevant information is marked uniquely according to the serial

number of each instrument. The equipment returned for repair must adopt the SN number as the tracking ID.

When you contact the engineer, the effective SN number of the instrument will be the effective guarantee for effective service and complete information. You can obtain the SN number of the instrument by the following ways:

1. Press the **[Menu]**→**System** key to enter into the system menu interface.
2. Use left and right keys or rotate the knob to select **System Info** and press **[Enter]** key.
3. Check the SN number.

Please record the SN number and provide SN information when doing maintenance service.

### How to contact ITECH engineers

Access ITECH official website [www.itechate.com](http://www.itechate.com).

## 5.4 Return for Repair

If your instrument fails during the warranty period, ITECH will repair or replace it under the terms of your warranty. After your warranty expires, ITECH offers repair services at competitive prices. Also you can purchase an extended maintenance service contract that exceeds the standard warranty period.

### Get Repair Service

To get the service for your instrument, choose the easiest way to contact the ITECH engineers. ITECH will arrange for repair or replacement of your instrument or provide warranty and repair cost information (if applicable).

### Repackaging for Shipment

#### **CAUTION**

**Never use styrene pellets in any shape as packaging materials. They do not adequately cushion the instrument or prevent it from shifting in the carton. Styrene pellets cause the instrument damage by generating static electricity and by lodging in the rear panel.**

---

ITECH recommends that you retain the original shipping carton for return shipments and always insure shipments. To ship the unit to ITECH for service or repair:

1. Download the ITECH maintenance service application from our website, complete it and place it in the box with the instrument.
2. Place the unit in its original container with appropriate packaging material.

If the original shipping container is unavailable, use a container that will ensure at least 10 cm (4 in.) of compressible packaging material around the entire instrument. Use static-free packaging materials.

3. Secure the container with strong tape or metal bands.

## Connect with us

Thank you for purchasing ITECH products. Any questions, pls. feel free to let us know.

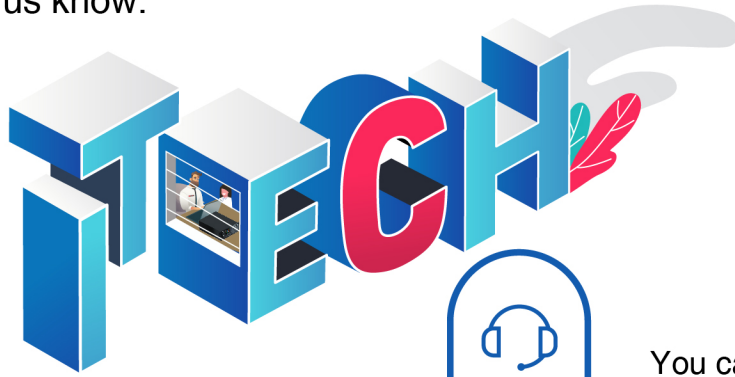

You can chat with us on ITECH website



For more information, pls. visit [www.itechate.com](http://www.itechate.com)



Click and follow ITECH Electronics

