

# High-power DC Power Supply

## IT6600D Series User Manual



---

Model: IT6600D

Version: V1.5/2026.2

## Notices

© Itech Electronic, Co., Ltd. 2026  
No part of this manual may be reproduced in any form or by any means ( including electronic storage and retrieval or translation into a foreign language) without prior permission and written consent from Itech Electronic, Co., Ltd. as governed by international copyright laws.

### Manual Part Number

IT6600D

### Revision

1st Edition: February 2,

2026.

Itech Electronic, Co., Ltd.

### Trademarks

Pentium is U.S. registered trademarks of Intel Corporation.

Microsoft, Visual Studio, Windows and MS Windows are registered trademarks of Microsoft Corporation in the United States and/or other countries and regions.

## Warranty

The materials contained in this document are provided “as is”, and is subject to change, without prior notice, in future editions. Further, to the maximum extent permitted by applicable laws, ITECH disclaims all warrants, either express or implied, with regard to this manual and any information contained herein, including but not limited to the implied warranties of merchantability and fitness for a particular purpose. ITECH shall not be held liable for errors or for incidental or indirect damages in connection with the furnishing, use or application of this document or of any information contained herein. Should ITECH and the user enter into a separate written agreement with warranty terms covering the materials in this document that conflict with these terms, the warranty terms in the separate agreement shall prevail.

### Technology Licenses

The hardware and/or software described herein are furnished under a license and may be used or copied only in accordance with the terms of such license.

### Restricted Rights Legend

Restricted permissions of the U.S. government. Permissions for software and technical data which are authorized to the U.S. Government only include those for custom provision to end users. ITECH provides this customary commercial license in software and technical data pursuant to FAR 12.211 ( Technical Data) and 12.212 ( Computer Software) and DFARS 252.227-7015 ( Technical Data – Commercial Items) and DFARS 227.7202-3 ( Rights in Commercial Computer Software or Computer Software Documentation).

## Safety Notices

### CAUTION

A CAUTION sign denotes a hazard. It calls attention to an operating procedure or practice that, if not correctly performed or adhered to, could result in damage to the product or loss of important data. Do not proceed beyond a CAUTION sign until the indicated conditions are fully understood and met.

### WARNING

A WARNING sign denotes a hazard. It calls attention to an operating procedure or practice that, if not correctly performed or adhered to, could result in personal injury or death. Do not proceed beyond a WARNING sign until the indicated conditions are fully understood and met.



### NOTE

A NOTE sign denotes important hint. It calls attention to tips or supplementary information that is essential for users to refer to.

## Quality Certification and Assurance

We certify that IT6600 series power supply meets all the published specifications at time of shipment from the factory.

## Warranty

ITECH warrants that the product will be free from defects in material and workmanship under normal use for a period of one ( 1 ) year from the date of delivery ( except those described in the Limitation of Warranty below).



### Note

Visit <https://www.itechate.com/en/support/register.html> to complete product registration by filling out the necessary information to extend the warranty to two (2) years.

For warranty service or repair, the product must be returned to a service center designated by ITECH.











- The product returned to ITECH for warranty service must be shipped PREPAID. And ITECH will pay for return of the product to customer.
- If the product is returned to ITECH for warranty service from overseas, all the freights, duties and other taxes shall be on the account of customer.



## Limitation of Warranty

This Warranty will be rendered invalid if the product is:

- Damaged resulting from customer-wired circuits or customer-supplied parts or accessories;
- Modified or repaired by customer without authorization;
- Damaged resulting from customer-wired circuits or use in an environment not designated by us;
- The product model or serial number is altered, deleted, removed or made illegible by customer;
- Damaged as a result of accidents, including but not limited to lightning, moisture, fire, improper use or negligence.

## Safety Symbols

	Direct current		ON ( power)
	Alternating current		OFF ( power)
	Both direct and alternating current		Power-on state
	Chassis (earth ground) symbol.		Power-off state
	Earth ( ground) terminal		Reference terminal

	Caution	+	Positive terminal
	Warning ( refer to this manual for specific Warning or Caution information)	—	Negative terminal
	A chassis terminal	-	-

## Safety Precautions

The following safety precautions must be observed during all phases of operation of this instrument. Failure to comply with these precautions or specific warnings elsewhere in this manual will constitute a default under safety standards of design, manufacture and intended use of the instrument. ITECH assumes no liability for the customer's failure to comply with these precautions.

### WARNING

- Do not use the instrument if it is damaged. Before operation, check the casing to see whether it cracks. Do not operate the instrument in the presence of inflammable gasses, vapors or dusts.
- The instrument is provided with a power cord during delivery and should be connected to a socket with a protective earth terminal, a junction box or a three-phase distribution box. Before operation, be sure that the instrument is well grounded.
- Check all marks on the instrument before connecting the instrument to power supply.
- Use electric wires of appropriate load. All loading wires should be capable of bearing maximum short-circuit of electronic load without overheating. If there are multiple loads, each pair of the load power cord must be carry out the full rated short-circuit output current of the power securely.
- Ensure the voltage fluctuation of mains supply is less than 10% of the working voltage range in order to reduce risks of fire and electric shock.
- Do not install alternative parts on the instrument or perform any unauthorized modification.
- Do not use the instrument if the detachable cover is removed or loosen.
- To prevent the possibility of accidental injuries, be sure to use the power adapter supplied by the manufacturer only.
- We do not accept responsibility for any direct or indirect financial damage or loss of profit that might occur when using the instrument.
- This instrument is used for industrial purposes, do not apply this product to IT power supply system.
- Never use the instrument with a life-support system or any other equipment subject to safety requirements.

### WARNING

- **SHOCK HAZARD Ground the Instrument.** This product is provided with a protective earth terminal. To minimize shock hazard, the instrument must be connected to the AC mains through a grounded power cord, with the ground wire firmly connected to an electrical ground (safety ground) at the power outlet or distribution box. Any interruption of the protective (grounding) conductor or disconnection of the protective earth terminal will cause a potential shock hazard that could result in injury or death.
- **Before applying power, verify that all safety precautions are taken.** All connections must be made with the instrument turned off, and must be performed by qualified personnel who are aware of the hazards involved. Improper actions can cause fatal injury as well as equipment damage.
- **SHOCK HAZARD, LETHAL VOLTAGES** This product can input the dangerous voltage that can cause personal injury, and the operator must always be protected from electric shock. Ensure that the input electrodes are either insulated or covered using the safety covers provided, so that no accidental contact with lethal voltages can occur.
- **Never touch cables or connections immediately after turning off the instrument.** Verify that there is no dangerous voltage on the electrodes or sense terminals before touching them.

#### CAUTION

- Failure to use the instrument as directed by the manufacturer may render its protective features void.
- Always clean the casing with a dry cloth. Do not clean the internals.
- Make sure the vent hole is always unblocked.

## Environmental Conditions

The instrument is designed for indoor use and an area with low condensation. The table below shows the general environmental requirements for the instrument.



Environmental Conditions	Requirements
Operating temperature	0°C~50°C
Operating humidity	20%~80%( non-condensation)
Storage temperature	-10°C~70 °C
Altitude	Operating up to 2,000 meters
Installation category	II
Pollution degree	Pollution degree 2



#### Note

To make accurate measurements, allow the instrument to warm up for 30 min.

## Regulatory Markings

	<p>The CE mark indicates that the product complies with all the relevant European legal directives. The specific year ( if any) affixed refers to the year when the design was approved.</p>
	<p>The instrument complies with the WEEE Directive ( 2002/96/EC) marking requirement. This affix product label indicates that you must not discard the electrical/electronic product in domestic household waste.</p>
	<p>This symbol indicates the time period during which no hazardous or toxic substances are expected to leak or deteriorate during normal use. The expected useful life of the product is 10 years. The product can be used safely during the 10-year Environment Friendly Use Period ( EFUP). Upon expiration of the EFUP, the product must be immediately recycled.</p>

## Waste Electrical and Electronic Equipment ( WEEE) Directive



2002/96/EC Waste Electrical and Electronic Equipment ( WEEE) Directive

This product complies with the WEEE Directive ( 2002/96/EC) marking requirement. This affix product label indicates that you must not discard the electrical/electronic product in domestic household waste.

Product Category

With reference to the equipment classifications described in the Annex 1 of the WEEE Directive, this instrument is classified as a "Monitoring and Control Instrument".

To return this unwanted instrument, contact your nearest ITECH office.

 **Compliance Information**

Complies with the essential requirements of the following applicable European Directives, and carries the CE marking accordingly:

- Electromagnetic Compatibility (EMC) Directive 2014/30/EU
- Low-Voltage Directive (Safety) 2014/35/EU

Conforms with the following product standards:

**EMC Standard**

IEC 61326-1 / EN 61326-1 <sup>123</sup>

**Reference Standards**

CISPR 11, Class A

IEC 61000-3-2

IEC 61000-3-3

IEC 61000-4-2

IEC 61000-4-3

IEC 61000-4-4

IEC 61000-4-5

IEC 61000-4-6

IEC 61000-4-11

1. The product is intended for use in non-residential/non-domestic environments. Use of the product in residential/domestic environments may cause electromagnetic interference.
2. Connection of the instrument to a test object may produce radiations beyond the specified limit.
3. Use high-performance shielded interface cable to ensure conformity with the EMC standards listed above.

**Safety Standard**

IEC 61010-1:2010+A1:2016

**Note**

This section provides general and universal terms. For more detailed information on the Declaration of Conformity, please contact ITECH personnel.

## Content

Quality Certification and Assurance .....	i
Warranty .....	i
Limitation of Warranty .....	i
Safety Symbols .....	i
Safety Precautions.....	ii
Environmental Conditions.....	iii
Regulatory Markings .....	iv
Waste Electrical and Electronic Equipment ( WEEE) Directive .....	iv
 Compliance Information .....	v
<b>Chapter1 Quick Reference .....</b>	<b>1</b>
1.1 Brief Introduction .....	1
1.2 Models and Options .....	1
1.3 Front Panel .....	4
1.4 Keyboard .....	6
1.5 Rear Panel .....	8
1.6 Home-Screen Overview .....	12
1.7 Instrument Installation and Dimensions .....	15
<b>Chapter2 Inspection and Installation .....</b>	<b>23</b>
2.1 Unpacking and Transportation .....	23
2.2 Verifying the Shipment.....	25
2.3 Connecting the Power Cord .....	26
2.4 Connecting Test Lines ( Optional).....	28
<b>Chapter3 Getting Started .....</b>	<b>32</b>
3.1 Power-on the Instrument .....	32
3.2 Touch Screen Introduction .....	33
3.3 Set output parameters .....	34
3.4 Output On/Off Control .....	34
<b>Chapter4 Power Supply Function.....</b>	<b>36</b>
4.1 Output Function .....	36
4.1.1 Set the Output Mode.....	36
4.1.2 Set the Output Priority Mode.....	37
4.1.3 Set Output Slew.....	38
4.1.4 Set the Internal Resistance .....	39
4.1.5 Set the Output-On/Output-Off Delay .....	40
4.1.6 Enable the Output .....	40
4.2 Protection Function.....	40
4.2.1 Over Voltage Protection .....	41
4.2.2 Over Current protection .....	41
4.2.2 Over Power protection .....	42
4.2.4 Under Voltage Protection.....	42
4.2.5 Under Current Protection .....	43
4.2.6 Set Maximum Voltage/Current/Power Limit.....	43
4.2.7 Over-temperature protection (OTP) .....	43
4.2.8 Sense Reverse Protection .....	44
4.3 LIST Function .....	44
4.3.1 ARB Function .....	48
4.4 Battery Charging Test Function .....	52
<b>Chapter5 System-Related Functions .....</b>	<b>54</b>
5.1 System Menu Reference .....	54
5.2 Configuration Menu Reference .....	58
5.3 Key Lock Function.....	58
5.4 Switching Local/Remote Mode .....	59
5.5 Save and Recall Operations .....	59

5.6	Screen Capture Function .....	60
5.7	Query the System Log .....	60
5.8	Multi-units operation .....	60
5.8.1	<i>Series Operation(single-unit)</i> .....	60
5.8.2	<i>Parallel Operation(single-unit)</i> .....	62
5.8.3	<i>Parallel Operation(multi-units)</i> .....	63
5.8.4	<i>Parallel Operation(one master and multi-slaves)</i> .....	68
5.8.5	<i>Parallel Operation(cabinet model)</i> .....	71
5.9	Digital I/O Function .....	75
5.9.1	<i>Description of Digital I/O pin</i> .....	75
5.9.2	<i>I/O Control</i> .....	78
5.10	Analogue Function (Ext-Program) (Optional).....	81
5.11	Redundant function .....	85
<b>Chapter6</b>	<b>Measurement Functions.....</b>	<b>87</b>
6.1	Meter Mode .....	87
6.2	Oscilloscope Mode .....	88
6.3	Recorder Function .....	91
<b>Chapter7</b>	<b>Technical Specifications .....</b>	<b>94</b>
7.1	Supplemental characteristics .....	94
7.2	Main technical parameters .....	94
IT6642D-1200-200	.....	94
IT6684D-1200-400	.....	96
IT66126D-1200-600	.....	98
IT66168D-1200-800	.....	100
IT66210D-1200-1000	.....	102
IT66252D-1200-1200	.....	104
IT66294D-1200-1400	.....	106
IT66336D-1200-1600	.....	108
IT66378D-1200-1800	.....	110
IT66420D-1200-2000	.....	113
IT6642D-1600-140	.....	115
IT6684D-1600-280	.....	117
IT66126D-1600-420	.....	119
IT66168D-1600-560	.....	121
IT66210D-1600-700	.....	123
IT66252D-1600-840	.....	125
IT66294D-1600-980	.....	127
IT66336D-1600-1120	.....	129
IT66378D-1600-1260	.....	131
IT66420D-1600-1400	.....	133
IT6642D-2250-100	.....	135
IT6684D-2250-200	.....	137
IT66126D-2250-300	.....	139
IT66168D-2250-400	.....	141
IT66210D-2250-500	.....	144
IT66252D-2250-600	.....	146
IT66294D-2250-700	.....	148
IT66336D-2250-800	.....	150
IT66378D-2250-900	.....	152
IT66420D-2250-1000	.....	154
<b>Chapter8</b>	<b>Remote Control .....</b>	<b>157</b>
8.1	USB Interface.....	157
8.2	LAN Interface.....	157
8.2.1	<i>Using Web Server</i> .....	158
8.2.2	<i>Using Telnet</i> .....	159
8.2.3	<i>Using Sockets</i> .....	160
8.2.4	<i>Using VNC</i> .....	160

---

8.3 CAN Interface .....	162
8.4 GPIB Interface (Optional) .....	163
8.5 RS232 Interface (Optional) .....	164
8.6 EtherCAT Interface (Optional) .....	166
<b>Appendix</b> .....	<b>167</b>
Specifications of Red and Black Test Lines .....	167

# Chapter1 Quick Reference

This chapter briefly introduces the front panel, rear panel, keyboard and screen display of the product, which provides you with a quick overview of its appearance, structure and key functions before operating. This chapter will not specify each operation in detail, it is just a guide to get you started quickly.

## 1.1 Brief Introduction

IT6600D series DC power supply is a new generation DC power supply. Its touch screen and intuitive GUI not only simplify parameter setting and waveform editing, but also improve convenience. It adopts advanced third-generation SiC technology. A 3U height single unit can output 21kW each in dual channels. If the two independent channels are connected in series/parallel, it can reach maximum power 42kW. Since 1 unit IT6600 can cover the output range of 3-5 normal power supplies, it can be applied to various applications requiring high voltage or high current.

IT6600D's CC/CV priority allows the output mode to be selected based on the specific needs of the DUT, which is especially important during precision measurements. High-precision, high-speed features and a variety of standard communication interfaces enable IT6600D to be widely used in laboratories, production lines and automatic test systems.

### Features

- High power density, up to 42kW in 3U.
- Independent dual-channel design in 3U unit, and channels can be connected in series or parallel.
- Master-slave current sharing, output max. 10MW in parallel.
- 5-inch touch screen with intuitive GUI.
- Data recorder function.
- Oscilloscope function, instant data analysis and saving.
- CC/CV priority.
- List function, dynamic working condition simulation with tens of millions of points.
- Redundancy function, helps to check the status of each single unit or cabinet and ensure the overall output.
- Built-in communication interface: USB/LAN/CAN 2.0B/Digital IO.
- Optional communication interface: GPIB/EtherCAT/Analog&RS232.

## 1.2 Models and Options

This series models include:

- **One master and multi-slaves series**

Model	Dual-channel output specifications	Parallel output specifications	Series Output Specifications	Height
IT6642D-1200-200	600V/100A/21kW*2ch	600V/200A/42kW*1ch	1200V/100A/42kW*1ch	3U

Model	Dual-channel output specifications	Parallel output specifications	Series Output Specifications	Height
IT6684D-1200-400	600V/200A/42kW*2ch	600V/400A/84kW*1ch	1200V/200A/84kW*1ch	15U
IT66126D-1200-600	600V/300A/63kW*2ch	600V/600A/126kW*1ch	1200V/300A/126kW*1ch	15U
IT66168D-1200-800	600V/400A/84kW*2ch	600V/800A/168kW*1ch	1200V/400A/168kW*1ch	27U
IT66210D-1200-1000	600V/500A/105kW*2ch	600V/1000A/210kW*1ch	1200V/500A/210kW*1ch	27U
IT66252D-1200-1200	600V/600A/126kW*2ch	600V/1200A/252kW*1ch	1200V/600A/252kW*1ch	27U
IT66294D-1200-1400	600V/700A/147kW*2ch	600V/1400A/294kW*1ch	1200V/700A/294kW*1ch	27U
IT66336D-1200-1600	600V/800A/168kW*2ch	600V/1600A/336kW*1ch	1200V/800A/336kW*1ch	37U
IT66378D-1200-1800	600V/900A/189kW*2ch	600V/1800A/378kW*1ch	1200V/900A/378kW*1ch	37U
IT66420D-1200-2000	600V/1000A/210kW*2ch	600V/2000A/420kW*1ch	1200V/1000A/420kW*1ch	37U

Model	Dual-channel output specifications	Parallel output specifications	Series Output Specifications	Height
IT6642D-1600-140	800V/70A/21kW*2ch	800V/140A/42kW*1ch	1600V/70A/42kW*1ch	3U
IT6684D-1600-280	800V/140A/42kW*2ch	800V/280A/84kW*1ch	1600V/140A/84kW*1ch	15U
IT66126D-1600-420	800V/210A/63kW*2ch	800V/420A/126kW*1ch	1600V/210A/126kW*1ch	15U
IT66168D-1600-560	800V/280A/84kW*2ch	800V/560A/168kW*1ch	1600V/280A/168kW*1ch	27U
IT66210D-1600-700	800V/350A/105kW*2ch	800V/700A/210kW*1ch	1600V/350A/210kW*1ch	27U
IT66252D-1600-840	800V/420A/126kW*2ch	800V/840A/252kW*1ch	1600V/420A/252kW*1ch	27U
IT66294D-1600-980	800V/490A/147kW*2ch	800V/980A/294kW*1ch	1600V/490A/294kW*1ch	27U
IT66336D-1600-1120	800V/560A/168kW*2ch	800V/1120A/336kW*1ch	1600V/560A/336kW*1ch	37U
IT66378D-1600-1260	800V/630A/189kW*2ch	800V/1260A/378kW*1ch	1600V/630A/378kW*1ch	37U
IT66420D-1600-1400	800V/700A/210kW*2ch	800V/1400A/420kW*1ch	1600V/700A/420kW*1ch	37U

Model	Dual-channel output specifications	Parallel output specifications	Series Output Specifications	Height
IT6642D-2250-100	1200V/50A/21kW*2ch	1200V/100A/42kW*1ch	2250V/50A/42kW*1ch	3U
IT6684D-2250-200	1200V/100A/42kW*2ch	1200V/200A/84kW*1ch	2250V/100A/84kW*1ch	15U
IT66126D-2250-300	1200V/150A/63kW*2ch	1200V/300A/126kW*1ch	2250V/150A/126kW*1ch	15U
IT66168D-2250-400	1200V/200A/84kW*2ch	1200V/400A/168kW*1ch	2250V/200A/168kW*1ch	27U
IT66210D-2250-500	1200V/250A/105kW*2ch	1200V/500A/210kW*1ch	2250V/250A/210kW*1ch	27U
IT66252D-2250-600	1200V/300A/126kW*2ch	1200V/600A/252kW*1ch	2250V/300A/252kW*1ch	27U
IT66294D-2250-700	1200V/350A/147kW*2ch	1200V/700A/294kW*1ch	2250V/350A/294kW*1ch	27U
IT66336D-2250-800	1200V/400A/168kW*2ch	1200V/800A/336kW*1ch	2250V/400A/336kW*1ch	37U
IT66378D-2250-900	1200V/450A/189kW*2ch	1200V/900A/378kW*1ch	2250V/450A/378kW*1ch	37U
IT66420D-2250-1000	1200V/500A/210kW*2ch	1200V/1000A/420kW*1ch	2250V/500A/420kW*1ch	37U

**● Multi-masters series**

Model	Dual-channel output specifications	Parallel output specifications	Series Output Specifications	Height
IT6684DM-1200-400	600V/200A/42kW*2ch	600V/400A/84kW*1ch	1200V/200A/84kW*1ch	15U
IT66126DM-1200-600	600V/300A/63kW*2ch	600V/600A/126kW*1ch	1200V/300A/126kW*1ch	15U
IT66168DM-1200-800	600V/400A/84kW*2ch	600V/800A/168kW*1ch	1200V/400A/168kW*1ch	27U
IT66210DM-1200-1000	600V/500A/105kW*2ch	600V/1000A/210kW*1ch	1200V/500A/210kW*1ch	27U
IT66252DM-1200-1200	600V/600A/126kW*2ch	600V/1200A/252kW*1ch	1200V/600A/252kW*1ch	27U
IT66294DM-1200-1400	600V/700A/147kW*2ch	600V/1400A/294kW*1ch	1200V/700A/294kW*1ch	37U
IT66336DM-1200-1600	600V/800A/168kW*2ch	600V/1600A/336kW*1ch	1200V/800A/336kW*1ch	37U
IT66378DM-1200-1800	600V/900A/189kW*2ch	600V/1800A/378kW*1ch	1200V/900A/378kW*1ch	37U

Model	Dual-channel output specifications	Parallel output specifications	Series Output Specifications	Height
IT6684DM-1600-280	800V/140A/42kW*2ch	800V/280A/84kW*1ch	1600V/140A/84kW*1ch	15U
IT66126DM-1600-420	800V/210A/63kW*2ch	800V/420A/126kW*1ch	1600V/210A/126kW*1ch	15U
IT66168DM-1600-560	800V/280A/84kW*2ch	800V/560A/168kW*1ch	1600V/280A/168kW*1ch	27U
IT66210DM-1600-700	800V/350A/105kW*2ch	800V/700A/210kW*1ch	1600V/350A/210kW*1ch	27U
IT66252DM-1600-840	800V/420A/126kW*2ch	800V/840A/252kW*1ch	1600V/420A/252kW*1ch	27U
IT66294DM-1600-980	800V/490A/147kW*2ch	800V/980A/294kW*1ch	1600V/490A/294kW*1ch	37U
IT66336DM-1600-1120	800V/560A/168kW*2ch	800V/1120A/336kW*1ch	1600V/560A/336kW*1ch	37U
IT66378DM-1600-1260	800V/630A/189kW*2ch	800V/1260A/378kW*1ch	1600V/630A/378kW*1ch	37U

Model	Dual-channel output specifications	Parallel output specifications	Series Output Specifications	Height
IT6684DM-2250-200	1200V/100A/42kW*2ch	1200V/200A/84kW*1ch	2250V/100A/84kW*1ch	15U
IT66126DM-2250-300	1200V/150A/63kW*2ch	1200V/300A/126kW*1ch	2250V/150A/126kW*1ch	15U
IT66168DM-2250-400	1200V/200A/84kW*2ch	1200V/400A/168kW*1ch	2250V/200A/168kW*1ch	27U
IT66210DM-2250-500	1200V/250A/105kW*2ch	1200V/500A/210kW*1ch	2250V/250A/210kW*1ch	27U
IT66252DM-2250-600	1200V/300A/126kW*2ch	1200V/600A/252kW*1ch	2250V/300A/252kW*1ch	27U
IT66294DM-2250-700	1200V/350A/147kW*2ch	1200V/700A/294kW*1ch	2250V/350A/294kW*1ch	37U
IT66336DM-2250-800	1200V/400A/168kW*2ch	1200V/800A/336kW*1ch	2250V/400A/336kW*1ch	37U
IT66378DM-2250-900	1200V/450A/189kW*2ch	1200V/900A/378kW*1ch	2250V/450A/378kW*1ch	37U

**Optional accessories**

The following optional accessories from ITECH are sold separately. Users need to purchase separately.

Device Name	Model	Description
GPIB communication interface	IT-E176	When the user needs to use GPIB interface to enable remote operation, this option is the right choice.
RS232+Analog	IT-E177	Interface card that includes RS232 communication interface and external analog. When the user needs to use RS232 or external analog interface to enable remote operation, this option is the right choice.
EtherCAT	IT-E1601-black	-
Fiber optic modules and cables	IT-E168	Used for parallel connection between the units in a cabinet, including one fiber module and two fiber cables, with lengths of 1.5 meters and 0.3 meters.  The fiber optic module and cable are the necessary accessories for the parallel connection. Different numbers of fiber optic modules and cables are used in different numbers of parallels.
Fiber optic modules and cables	IT-E169	Used for parallel connection between cabinets, including one fiber module and one 2.5m fiber cable.  The fiber optic module and cable are the necessary accessories for the parallel connection. Different numbers of fiber optic modules and cables are used in different numbers of parallels.
Relay board	IT-E179	-
Series and parallel boxes	IT-E183	Cabinet configuration, direct switching between series and parallel.

## 1.3 Front Panel

- **One master and multi-slaves series**

All of this series instruments have the same front panel. The front panel diagram and key diagram of 3U model is shown in the figure below; descriptions of the numbered items follow the figure.

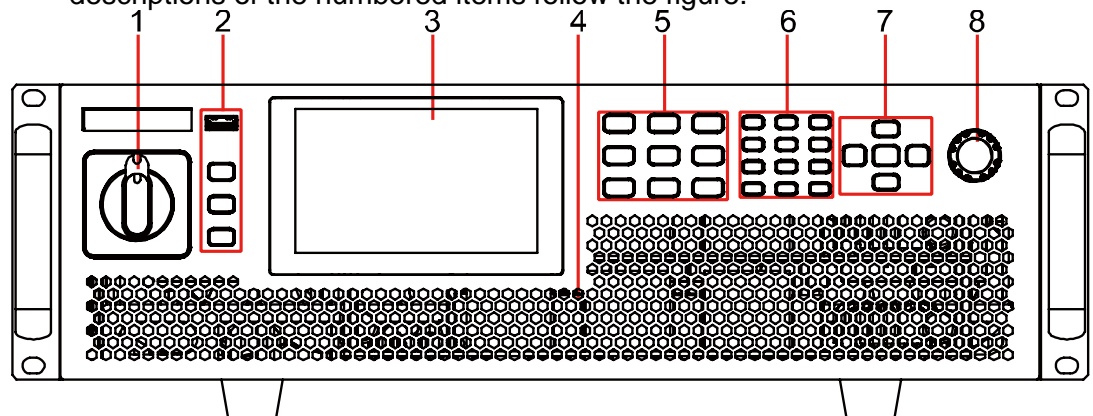

1 Power Switch  
3 LCD touch screen

2 USB interface /Print/View/Menu  
4 Vent hole

- 5 Function key
- 6 Number key
- 7 Up, down, left and right key and enter key
- 8 Rotary knob

● **Multi-masters series**

The front panel buttons of this series of instruments are the same; the differences lie in the output power or the cabinet size. Below are the front panel diagram and button function diagram for the 27U model.

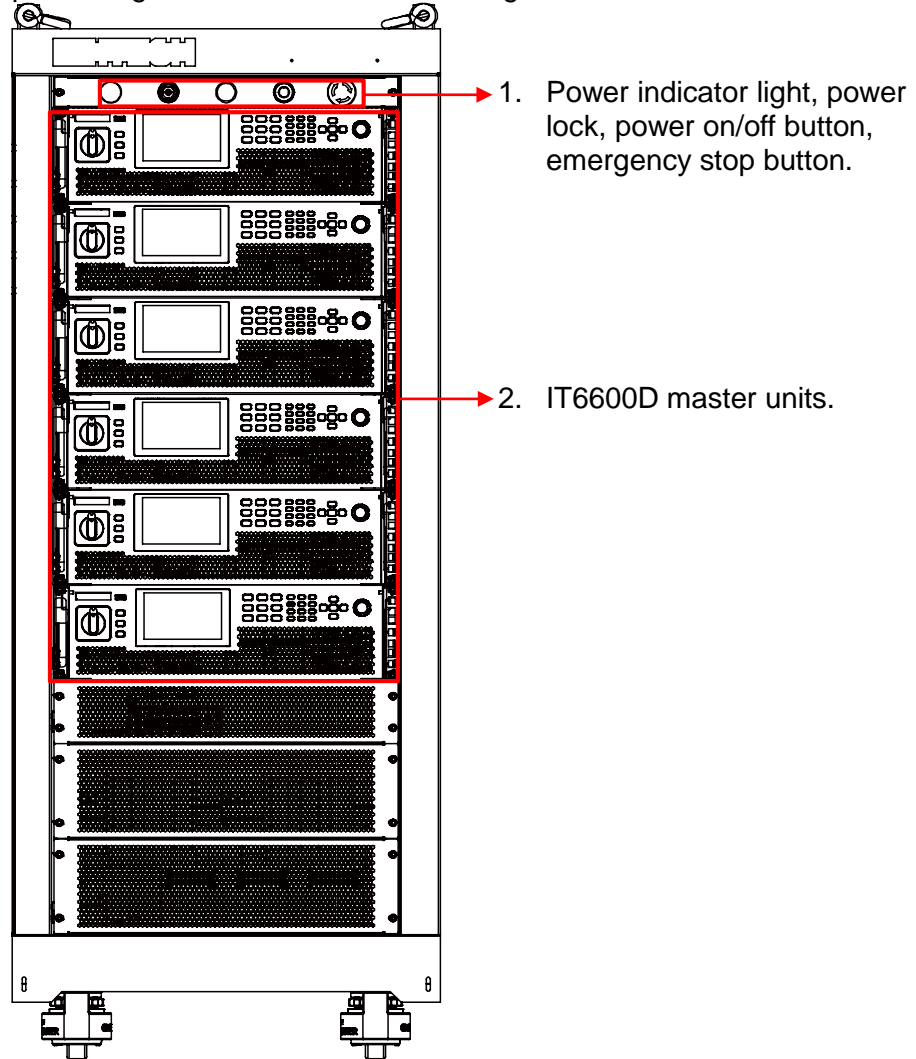

1. Power indicator light, power lock, power on/off button, emergency stop button.

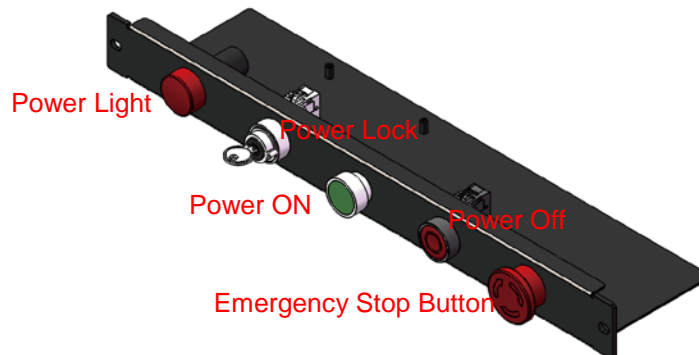

Detailed function description is shown below:

- Power light: When the power switch is pressed, the power light is lighted on.
- After the power lock is activated, press the green power on button

to power up the cabinet; when the power lock is deactivated, the green power on button is disabled, preventing the cabinet from powering up.

- The power on button is a green button; pressing the power on button will power up the cabinet.
- The power off button is a red button; pressing the power off button will power down the cabinet.
- The emergency stop button is a rotary resetting button. When the emergency stop button is pressed, the cabinet is powered off; after rotary resetting, the cabinet is powered on.

2. IT6600D master units.

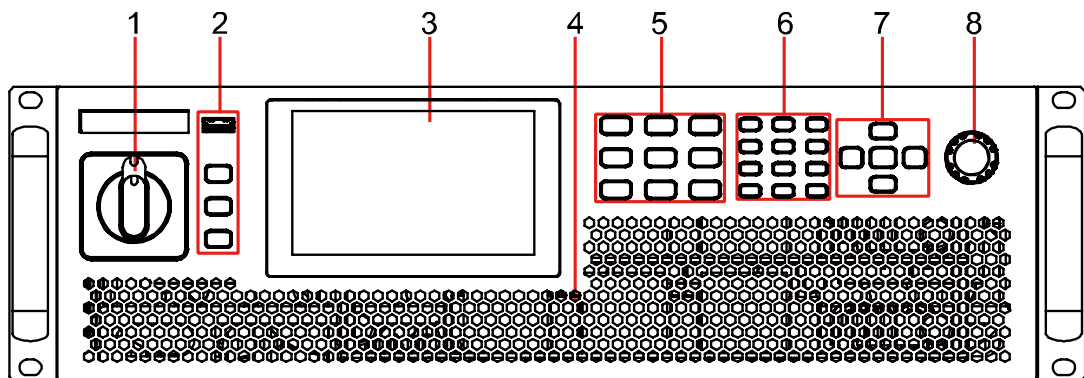

- |  |                                  |
|--|----------------------------------|
| 1 Power Switch                               | 2 USB interface /Print/View/Menu |
| 3 LCD touch screen                           | 4 Vent hole                      |
| 5 Function key                               | 6 Number key                     |
| 7 Up, down, left and right key and enter key | 8 Rotary knob                    |

## 1.4 Keyboard

The keyboard introduction of IT6600 series Power Supply is shown as follows.

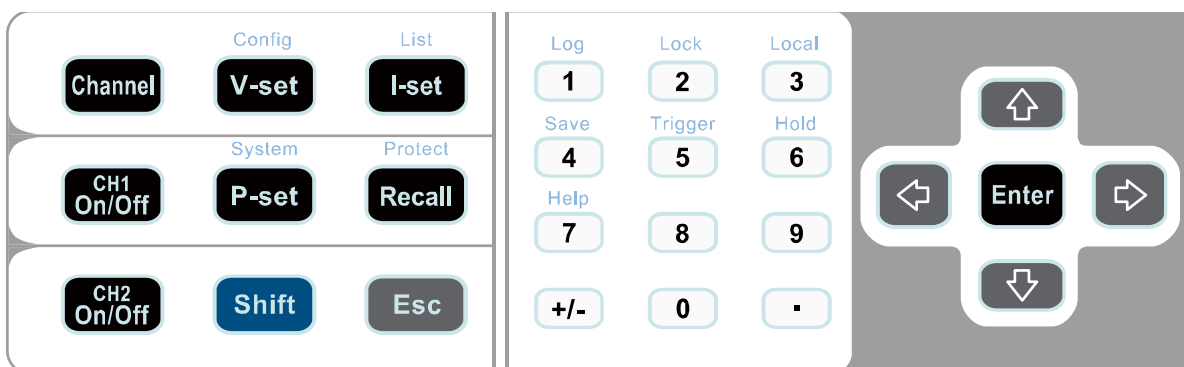

Keys	Description
Power	Power Switch
Print	Used for saving screen images.
View	Interface display switch key. <ul style="list-style-type: none"> <li>● In Normal working mode, use this key to switch between the Meter interface, Scope interface, and Recorder interface.</li> <li>● In non-Normal working mode, use this key to switch between the function interface, Scope interface, and Recorder interface.</li> </ul>

Keys	Description
Menu	Used for going back to menu page.
<b>[Channel]</b>	Switch channels.
<b>[V-set]</b>	Set the output voltage value.
<b>[I-set]</b>	Set the output current value.
<b>[P-set]</b>	Set the output power value.
<b>[Recall]</b>	Returns the instrument to the specified setup.
<b>[Shift]</b>	Composite key, combined with other keys to realize functions marked above keys.
<b>[Esc]</b>	Press this key to exit the current operation interface.
<b>CH1 On/Off</b>	Turn the CH1 output on or off.
<b>CH2 On/Off</b>	Turn the CH2 output on or off.
<b>[0]-[9]</b>	Number key. Enter the number directly.
+/-	Positive and negative signs.
.	Decimal point.
Left / Right Navigation keys	The left and right navigation keys are used to adjust the cursor to the specified position or scrolls pages to view menu items.
Up / Down Navigation keys	The up and down navigation keys are used to scroll page up and down to view menu items.
<b>[Enter]</b>	Operation confirmation key

Composite key **[Shift]**, combined with other keys to realize functions marked above keys. Firstly, press **[shift]** and the shift key will be lighted, and then press the function key, the detailed functions are listed as follows.

Keys	Description
[Shift]+[V-set] (Config)	Enter to Configuration menu.
[Shift]+[I-set] (List)	Enter the List function menu.
[Shift]+[P-set] (System)	Enter the System menu.
[Shift]+[Recall](Protect)	Enter the Protect menu of the power supply.
[Shift]+[1](Log)	Enter the Log query interface.
[Shift]+ [2] (Lock)	Turn the keyboard lock on or off.
[Shift]+[3] (Local)	Switch remote control mode to local control mode.
[Shift]+[4] (Save)	Save the common parameter settings.
[Shift]+ [5] (Trigger)	Used for manual trigger.
[Shift]+ [6] (Hold)	When you need to keep the present meter status, you can press the keys. Then the present meter status display and will be kept no matter whether output is running.
[Shift]+ [7] (Help)	Obtain the help information.

## Push-on Knob

The IT6600 series Power Supply provides a knob on the front panel as shown

in the next figure.



The functions of the push-on knob is described as follows.

- Adjust the value setting.
- Select menu item.
- Confirm the set value or the selected menu item.

## Adjust the Value Setting

In the value setting interface, rotate the knob clockwise to increase the set value and anticlockwise to decrease the set value.

## Select Menu Item

The knob can also be used to view menu items. In the menu item display interface, turning the knob clockwise indicates that the next menu item is selected, and turning the knob anticlockwise indicates that the previous menu item is selected.

## Confirm settings

After completing the value setting or selecting a menu item, pushing the knob acts like pressing **[Enter]** key to confirm the operation.

## 1.5 Rear Panel

- **One master and multi-slaves series**

The rear panel of the IT6600 series 3U model is shown below.

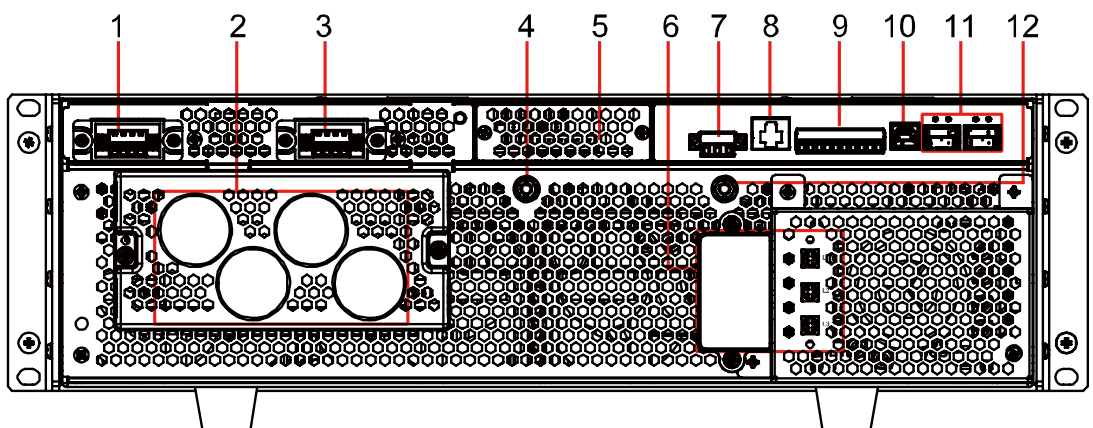

No.	Name	Description
1	Remote sense Terminals (CH1)	VS1- and VS1+ are remote sense terminals, used for maximizing measurement accuracy.
2	DC output terminals	Used to connect DUT. (Hole size M8)

3	Remote sense Terminals (CH2)	VS2- and VS2+ are remote sense terminals, used for maximizing measurement accuracy.
4	Ground screw	Grounding terminal for connecting the ground of other devices.
5	Optional expansion slot	Optional interfaces: (Plastic plugs are inserted by default when the user does not purchase the interface.) The optional interface as follows: <ul style="list-style-type: none"> <li>● GPIB</li> <li>● RS232/ Analog interface</li> <li>● EtherCAT</li> <li>● Relay board</li> </ul>
6	AC power input socket	Used to connect AC power to start instrument.
7	External control interface CTRL	This interface is used for the parallel connection between the master (with operation panel) and the slaves (without operation panel). Connect the interface on the rear panel of each unit to be connected in parallel, and the master can offer synchronous control over the power-on/off of the slaves.
8	LAN interface	LAN communication interface.
9	I/O terminals/CAN interface	<ul style="list-style-type: none"> <li>● Digital Port</li> <li>● CAN communication interface CAN-H and CAN-L</li> </ul>
10	USB interface	USB communication interface.
11	System Bus	Used for communication between instruments in parallel operation feature. <ul style="list-style-type: none"> <li>● F-TX/F-RX: This interface is used for the parallel connection between the master (with operation panel) and the slaves (without operation panel) for realizing communication of units in parallel.</li> <li>● TX/RX: This interface is used for the parallel connection between the masters (with operation panel) for the communication of units in parallel.</li> </ul>
12	Ground screw	Protective grounding terminal for AC input.

Schematic Diagram of Rear Panel of this series (15U) instrument is shown as below, model 27U and model 37U have the same rear panels as 15U model. Only the sizes are different.

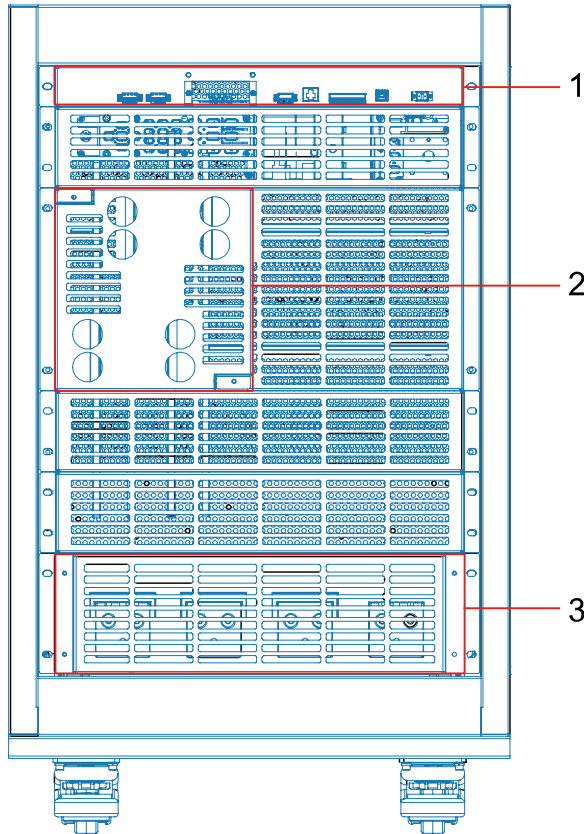

1. The communication interface for cabinet, the detailed diagram as follows, and the descriptions are the same as 3U model.



2. Output terminals (Hole size M8) and protective cover.
3. Input terminal (Hole size M8), connected to the instrument's power supply.

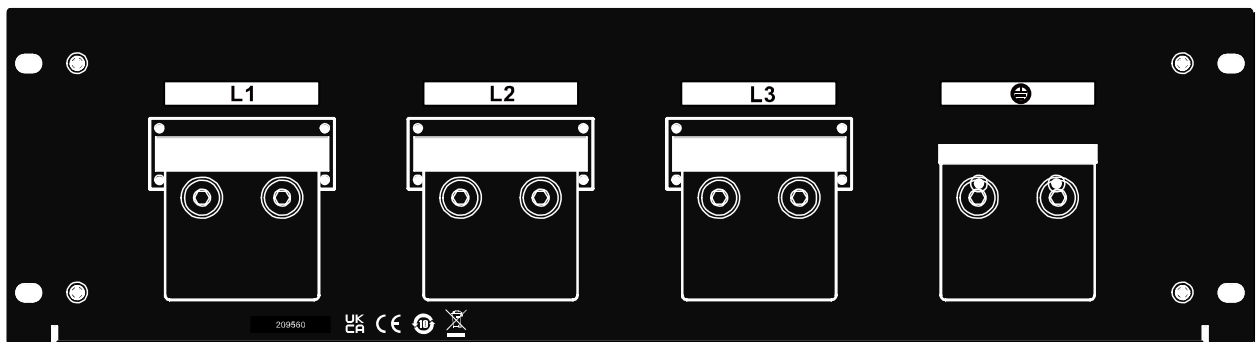

- **Multi-masters series**  
 Except for the size differences, the rear panel terminals of this series of instruments are completely identical. The following introduction uses the 27U cabinet as an example.

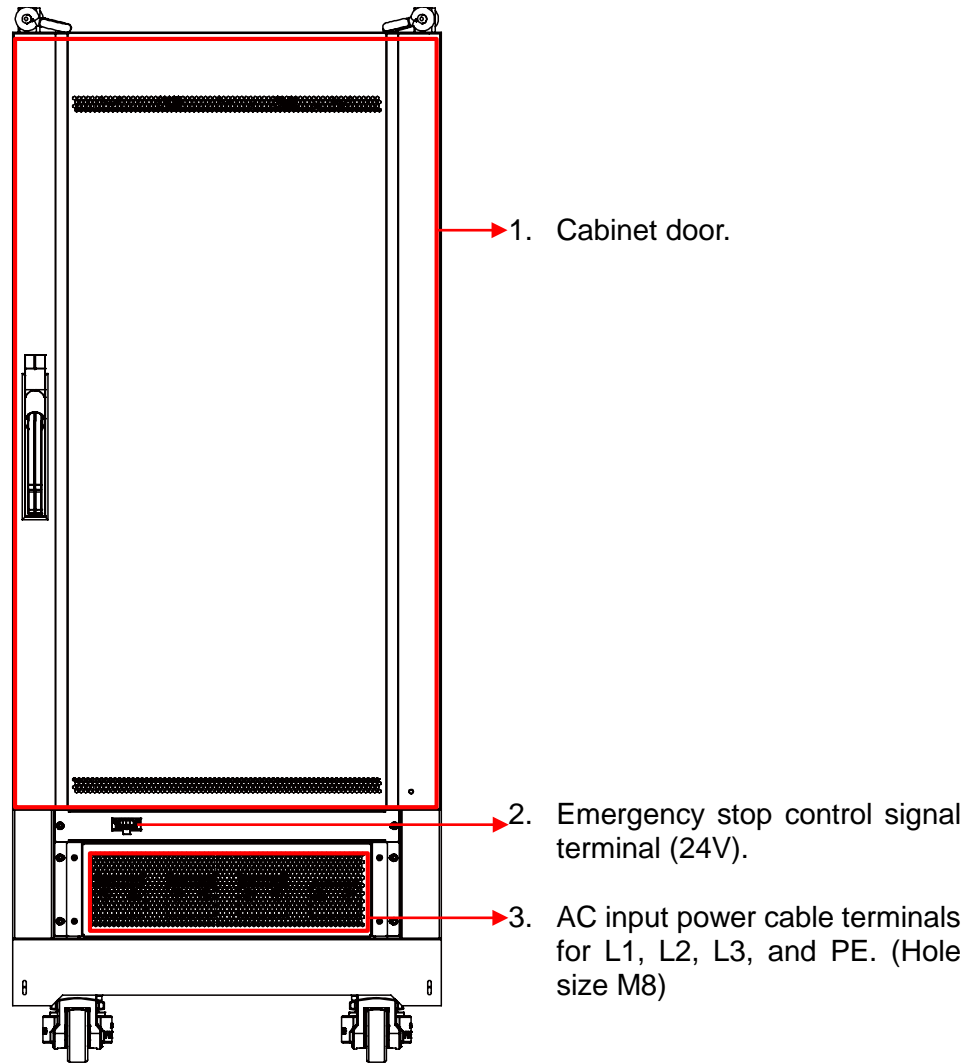

1. Cabinet door. (Make sure the cabinet door is securely closed before powering on.)
2. Emergency stop control signal terminal (24V).  
Pin2 and Pin3 of the terminal are shorted by default, as shown in the figure below.

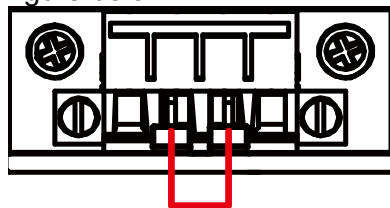

When the cabinet is powered on and off by the emergency stop button on the front panel of the cabinet, make sure that the short-circuit clips here are correctly installed.

When controlling the power on and off of the cabinet (emergency stop) through external cables, refer to the following steps:

- a. Remove the short-circuit clip between Pin2 and Pin3.  
**Note: Lead 24V voltage signal.**
- b. Refer to the figure below to connect to the external signal control circuit.

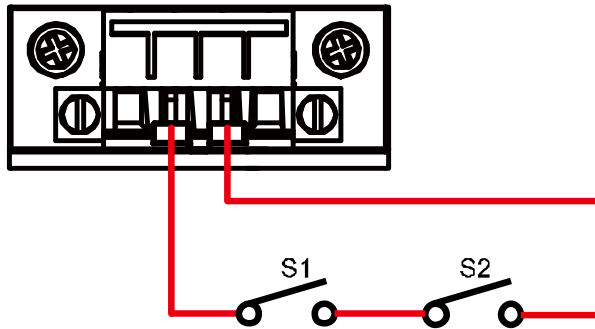

S1: Cage door switch by customer

S2: External switch by customer

Note: When both A and B are closed, the cabinet is powered on; if either A or B is disconnected, an emergency stop is triggered and the cabinet is powered off. If you need to power on the cabinet again, make sure that the switches at A and B are closed.

- AC input power cable terminals for L1, L2, L3, and PE. (Hole size M8)

## 1.6 Home-Screen Overview

IT6600 series power supply adopts touch screen design, the users can easily operation by touch screen. The details of the home screen are described below.

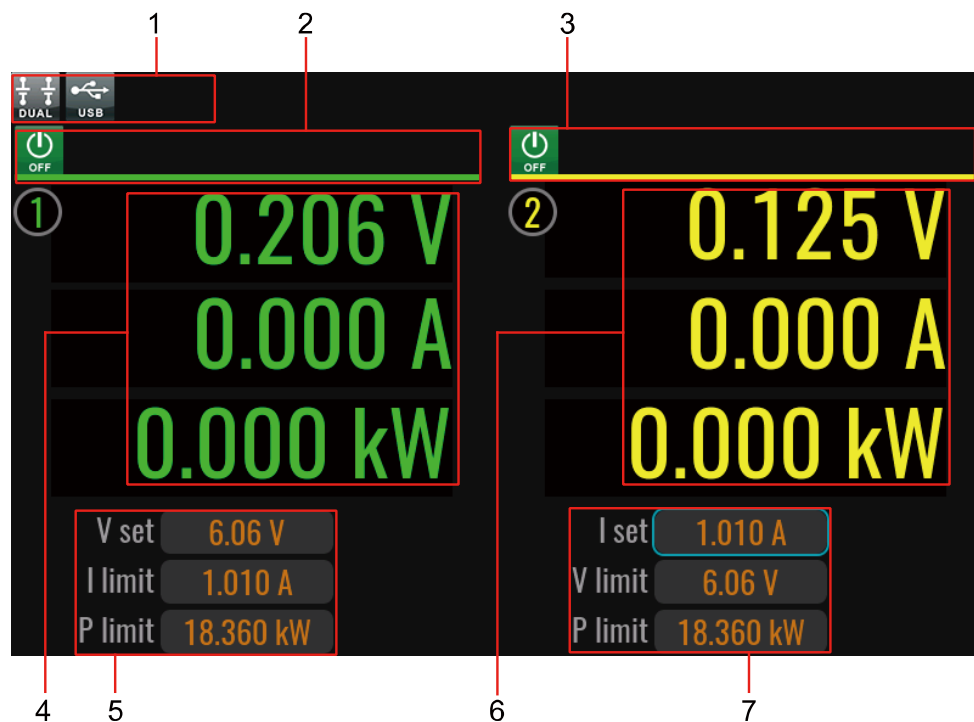









































No.	Name	Description
1	Power status bar	Displays the present output status.
2	CH1 status bar	Displays the output status of power channel 1.
3	CH2 status bar	Displays the output status of power channel 2.
4	Output values view area for CH1	Displays the present output voltage, current and power values.

5	Setting values view area for CH1	<ul style="list-style-type: none"> <li>When CV is prioritized, the voltage setting value, current upper limit value, and power upper limit value are displayed.</li> <li>When CC is prioritized, the current setting value, voltage upper limit value, and power upper limit value are displayed.</li> </ul>
6	Output values view area for CH2	Displays the present output voltage, current and power values.
7	Setting values view area for CH2	<ul style="list-style-type: none"> <li>When CV is prioritized, the voltage setting value, current upper limit value, and power upper limit value are displayed.</li> <li>When CC is prioritized, the current setting value, voltage upper limit value, and power upper limit value are displayed.</li> </ul>

## Introduction to Interface Symbols

The interface of IT6600 power supply will display the following symbols. All the symbols and description are listed in the table below.

Char	Function description	Char	Function description
Shift	Compound key.		Output is off.
	Output is on.		Key operation is locked.
	The power supply is in a state of constant current output.		The power supply is in a state of constant voltage output.
	The power supply is in a state of constant power output.		Touch function is disabled.
	The DV source is in remote mode.		Sense indicator.
	2-channel independent output mode.		Found USB disk.
	2-channel series mode.		2-channel parallel mode.
	LIST is running.		LIST is finished.
	LIST function is waiting for trigger.		BAT is running.
	BAT is finished.		BAT function is waiting for trigger.
	DLOG is running.		DLOG is finished.
	DLOG function is waiting for trigger.		ELOG function is waiting for trigger.
	ELOG is running.		ELOG is finished.

Char	Function description	Char	Function description
	SYNC lock		SYNC unlock
	Fiber is error.		Output is disabled.
	Over current protection.		Over temperature protection.
	Over voltage protection.		Over power protection.
	Sense Error.		Under current protection.
	Under voltage protection.		Communication command error.
	Tip image is folded, click to expand all icons.		Analogue Function
	Device calibration modes.		Data recording function.

## Menu Introduction

Press the **[Menu]** key on the front panel and enter to the menu interface. Menu interface will display all of function icon, user can rotate the knob or direction key to select, or click the screen to enter the function interface.

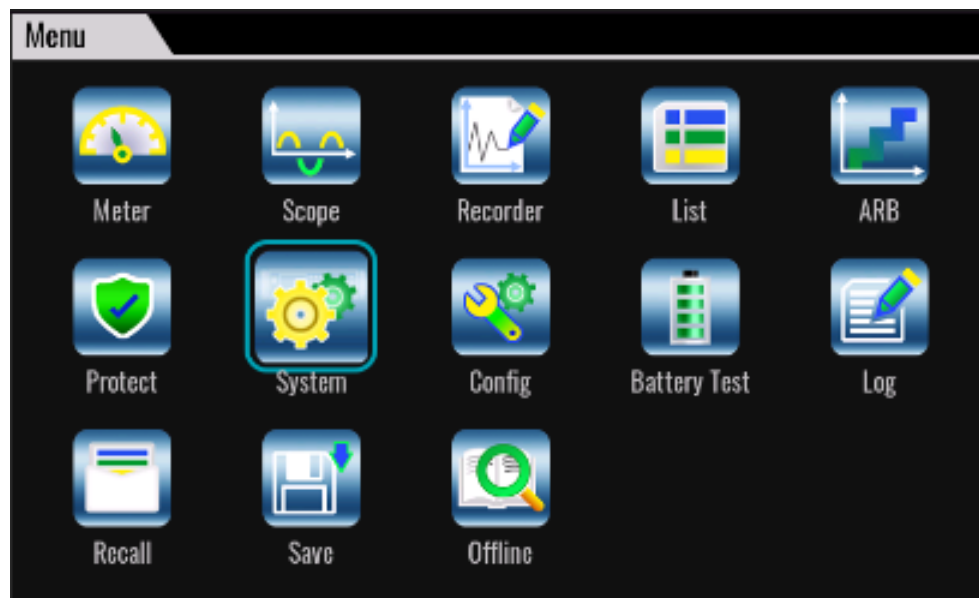

## 1.7 Instrument Installation and Dimensions

The instrument is equipped with air inlet and outlet vents at specific locations to ensure effective heat dissipation. When installing the instrument into a rack, make sure the airflow path remains unobstructed, and leave sufficient ventilation space around the cooling vents. Proper airflow direction must be maintained to ensure stable and reliable operation of the instrument. The following section provides an example using the 3U model.

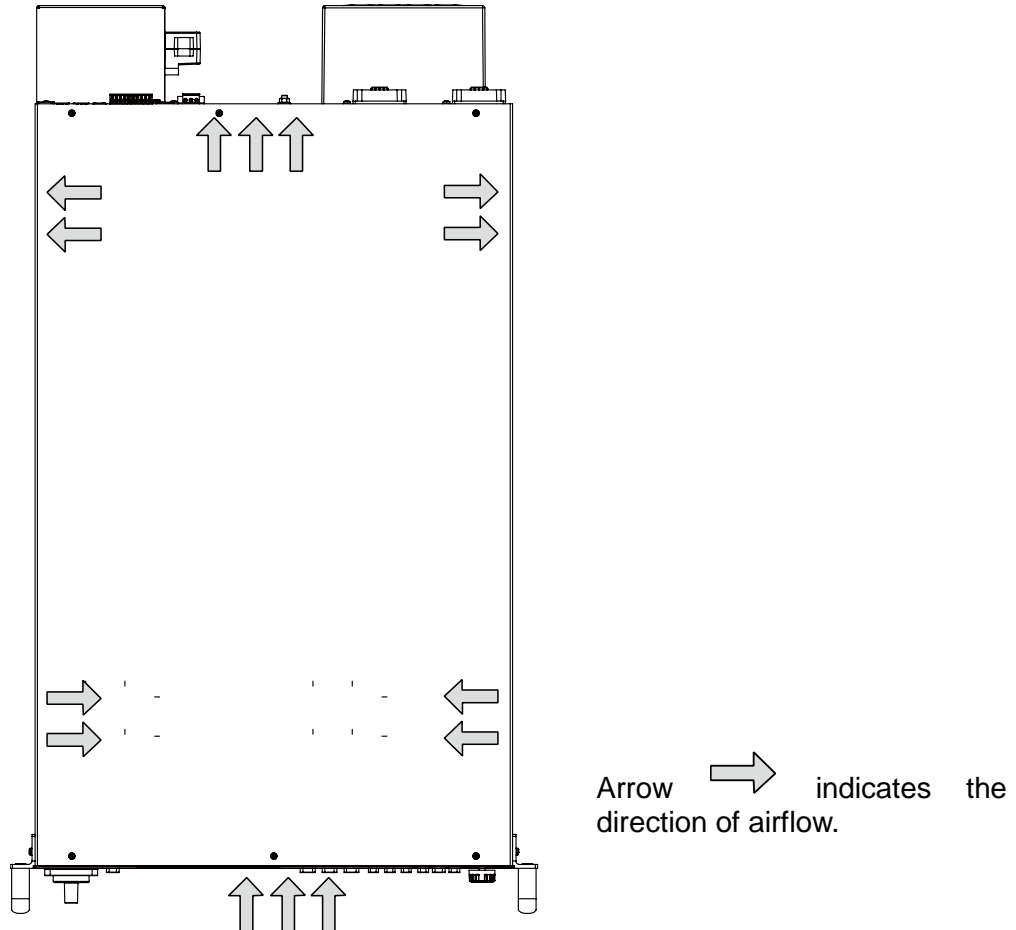

### Installation Clearance Requirements for Standalone Units/Cabinets:

- **Rear Clearance:** The rear of the instrument must remain unobstructed. To ensure proper airflow and allow for the opening and closing of the rear door, the minimum clearance between the rear panel and the wall should be 1 meter.
- **Front Clearance:** The front of the instrument must remain unobstructed to allow for personnel access and adequate airflow for cooling. The minimum clearance between the front panel and the nearest wall or large surface should be 850 millimeters.
- **Side Clearance:** Both sides of the instrument should be free of obstructions. To ensure proper airflow, the minimum clearance between the side panels and the nearest wall or large surface should be 850 millimeters.

The detailed dimension drawings of the IT6600 series are as follows (unit:mm).

3U Model

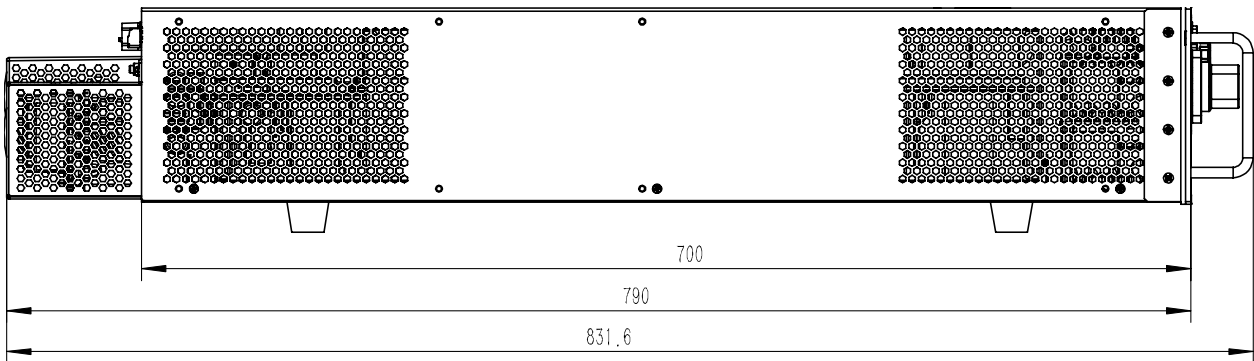
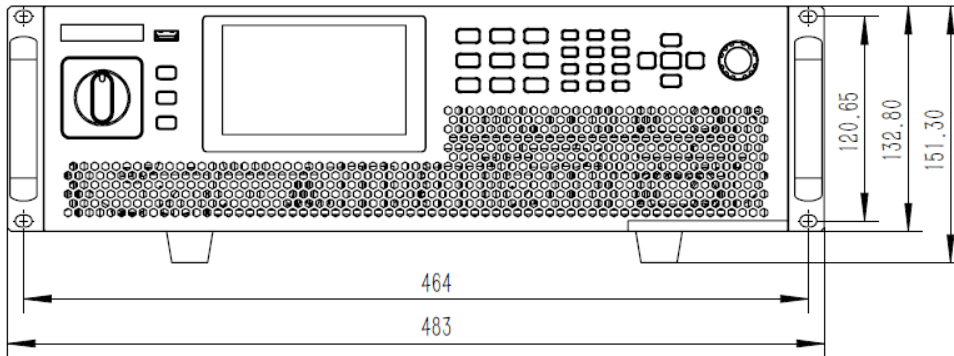
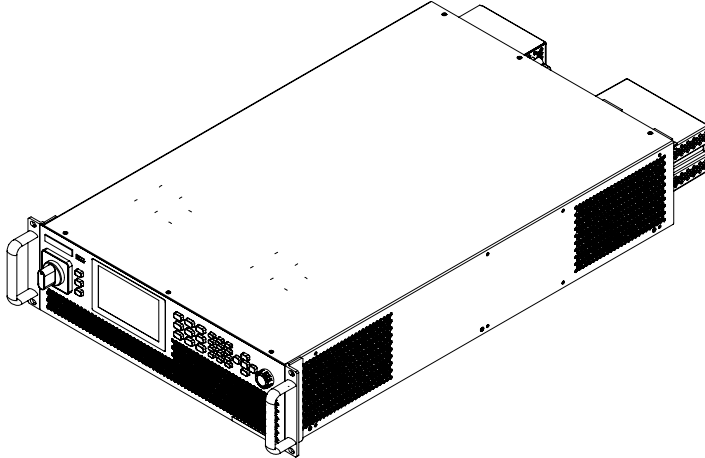

15U Model (One master and multi-slaves series)

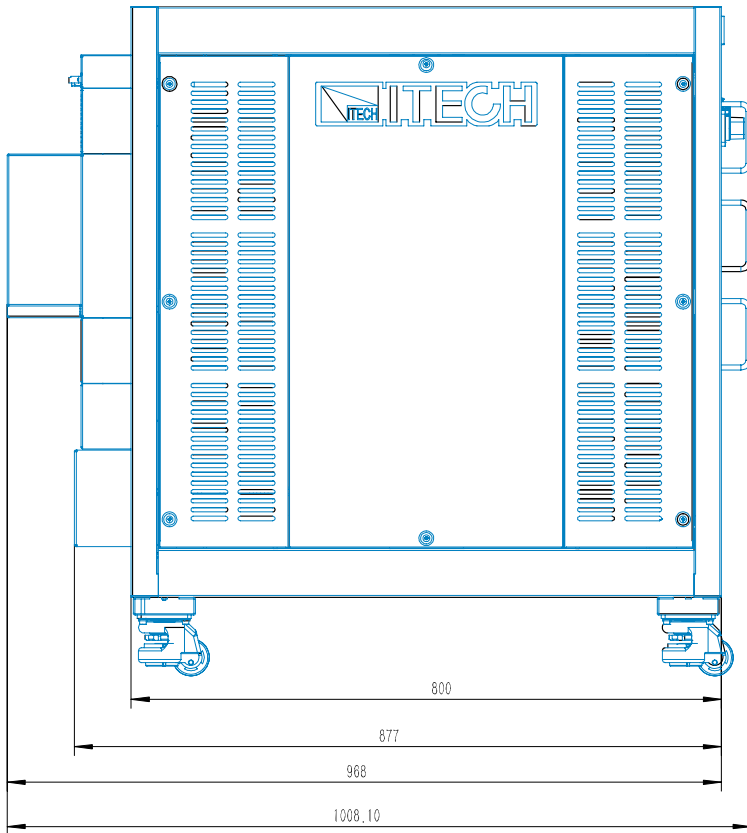
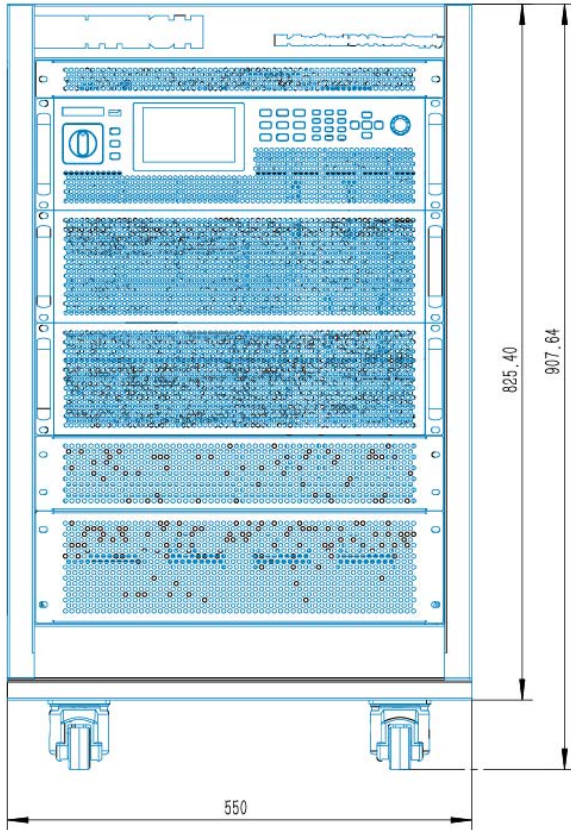

27U Model (One master and multi-slaves series)

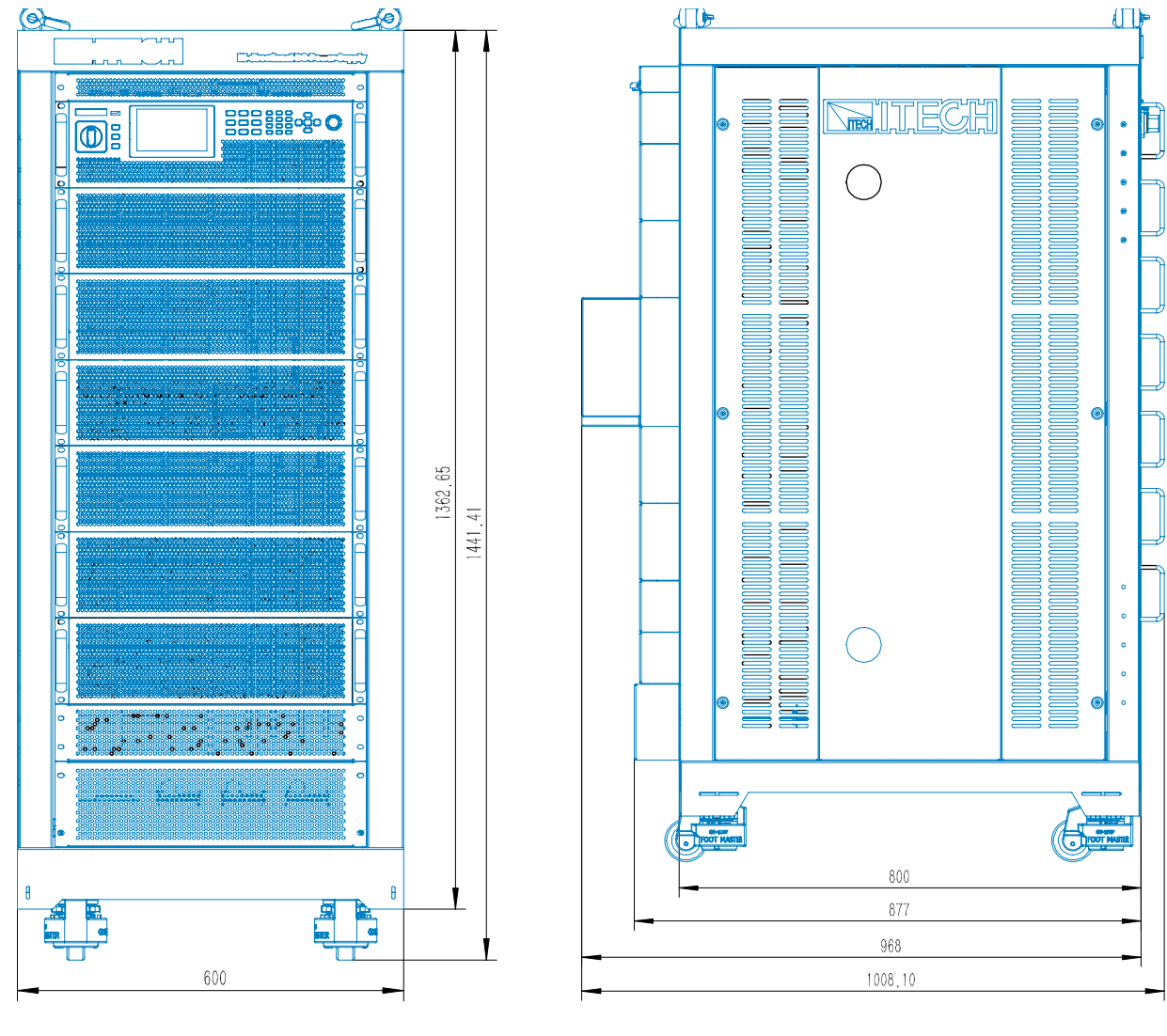

37U Model (One master and multi-slaves series)

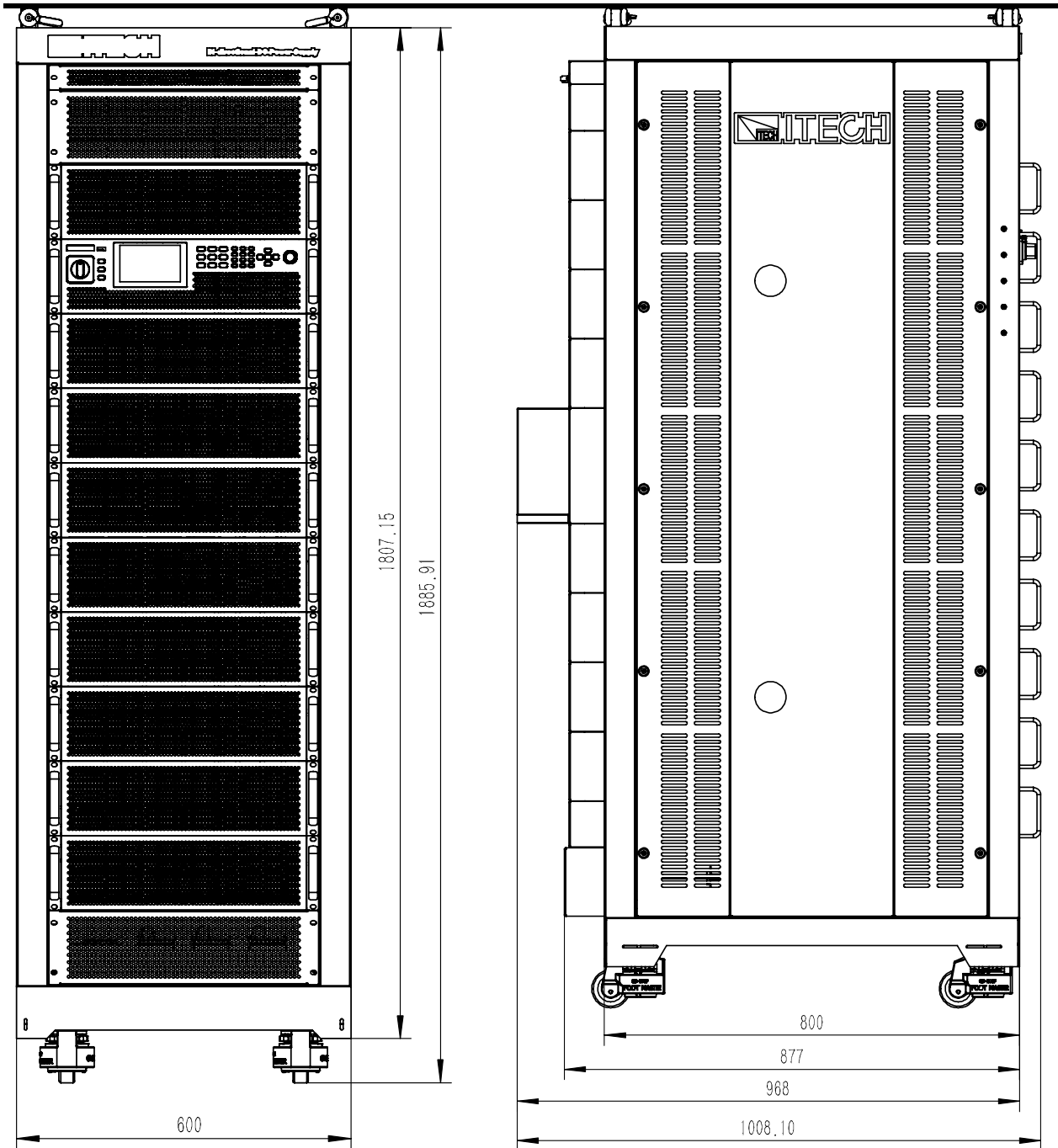

15U Model (Multi-masters series)

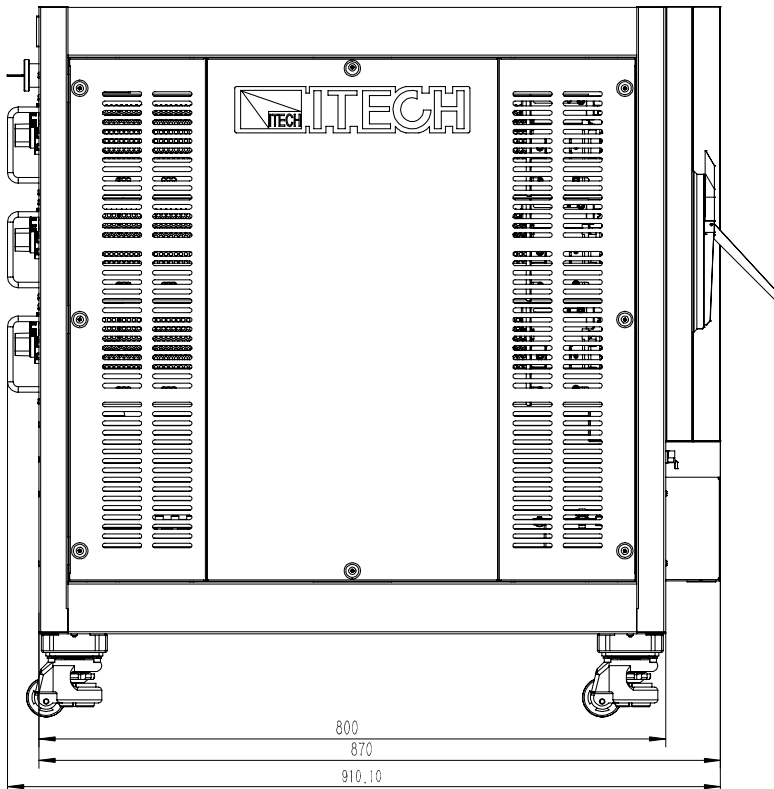
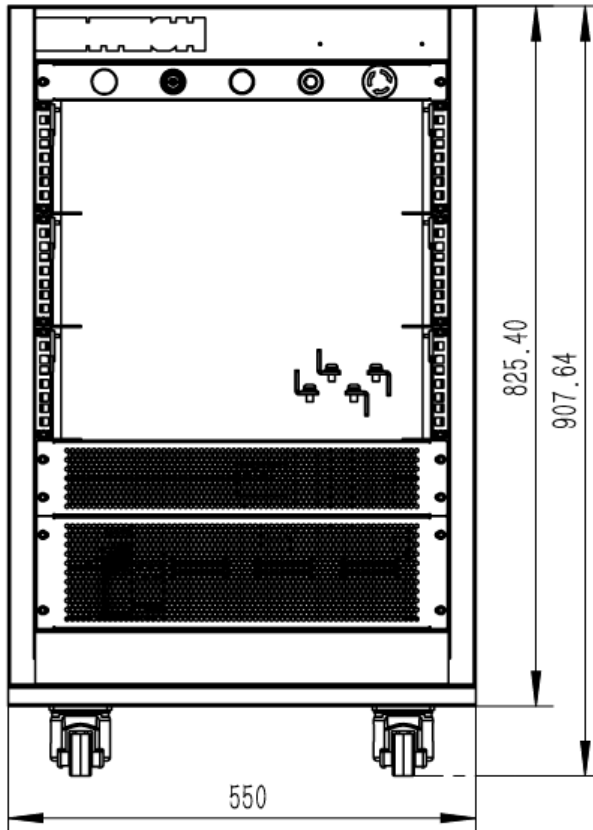

27U Model (Multi-masters series)

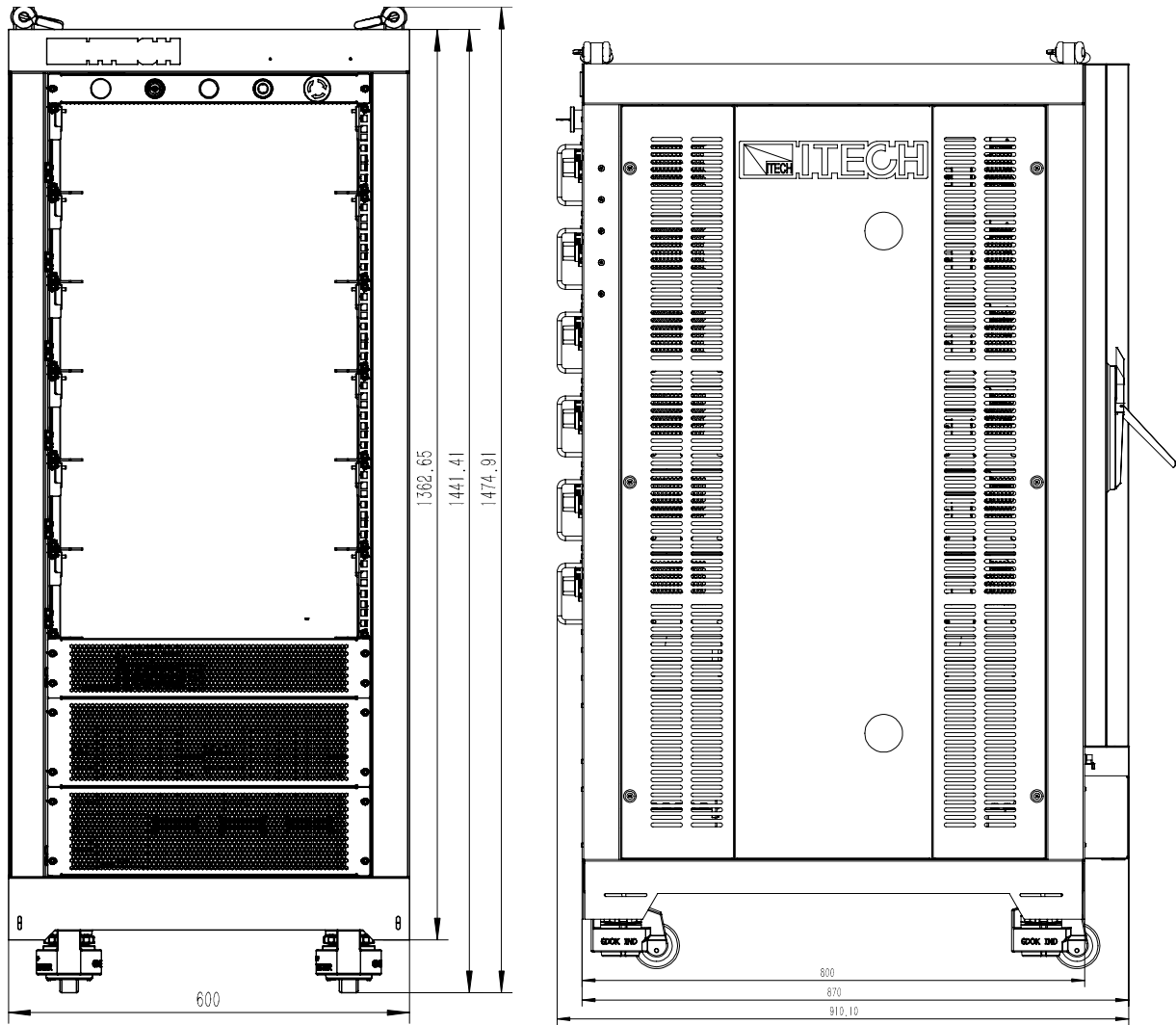

37U Model (Multi-masters series)

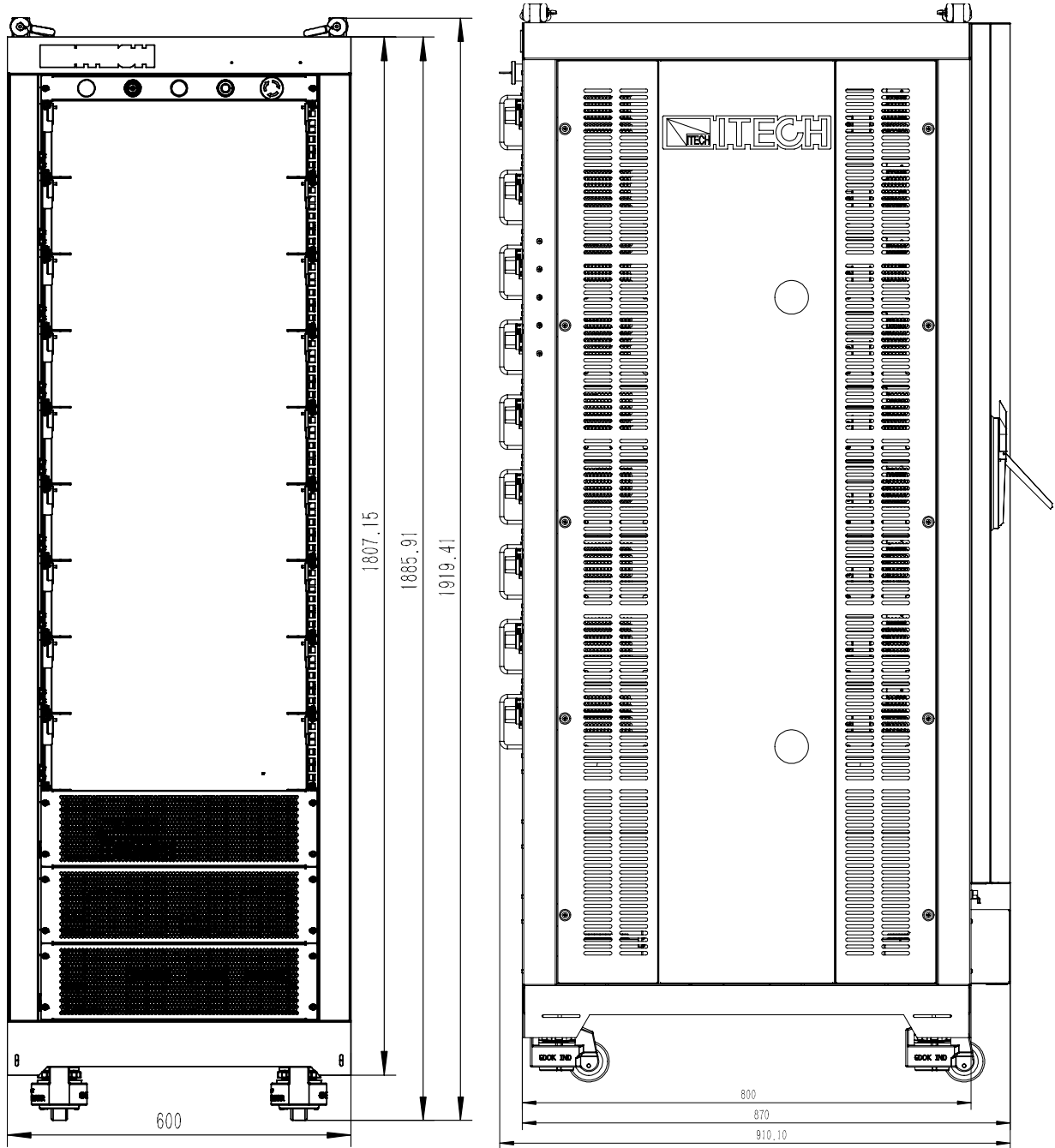

# Chapter2 Inspection and Installation

## 2.1 Unpacking and Transportation

### Unpacking



For cabinet products, they are packaged in wooden boxes at the factory. After you receive them, please refer to the unpacking instructions provided with the box for disassembly; for products packaged in cartons, please use appropriate tools for unpacking.

It is recommended to keep the complete transport packaging for the lifetime of the device for relocation or return to the manufacture for repair.

### Cabinet Safety Symbols

A sticker bearing the following safety symbols is affixed to the upper left corner of the rear panel of the cabinet, as described below.

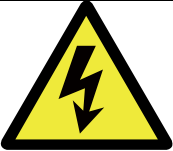

Symbols	Introduction
	<p><b>General Warning</b></p> <ul style="list-style-type: none"> <li>● <b>Meaning:</b> General warning, alerting personnel to potential hazards or important notices.</li> <li>● <b>Description:</b> Indicates that the operation manual or safety instructions should be read to ensure awareness of potential risks.</li> </ul>
	<p><b>Electric Shock Hazard</b></p> <ul style="list-style-type: none"> <li>● <b>Meaning:</b> Risk of electric shock.</li> <li>● <b>Description:</b> Indicates that high voltage or residual voltage may be present inside the equipment or at its terminals, posing an electric shock hazard if touched.</li> </ul>
	<p><b>High Temperature Warning</b></p> <ul style="list-style-type: none"> <li>● <b>Meaning:</b> High temperature warning.</li> <li>● <b>Description:</b> The surface may become hot during operation and can cause burns if touched; protection should be used or contact should be avoided until cooled.</li> </ul>
	<p><b>Tip-Over Hazard</b></p> <ul style="list-style-type: none"> <li>● <b>Meaning:</b> Prevent equipment from tipping over or avoid collision-related injuries.</li> <li>● <b>Description:</b> Indicates that the equipment may tip over during transport, relocation, or unstable installation, and anti-tip measures should be taken to prevent personal injury or equipment damage.</li> </ul>

## Transportation

If you need to transport non-cabinet products, you must pay attention to the following to ensure the safety of equipment and personnel.

### CAUTION

- Before moving, make sure that the cabinet or stand where the equipment will be placed has been fixed and meets the load-bearing conditions to avoid tilting and collapsing, causing personnel to be injured, and equipment broken.
- Due to the weight of the product, transport by hand should be avoided where possible. If unavoidable, carry it with two people and holding the product shell and not external parts (such as handles, electrodes, knobs, etc.).
- When carrying, be prepared to bear the weight to avoid sprains or being crushed by heavy objects.
- Use suitable safety clothing, especially safety shoes, when carrying the equipment, as due to its weight a fall can have serious consequences.

---

After unpacking the cabinet product, if you need to move it to other places, you must pay attention to the following matters to ensure the safety of equipment and personnel.

### CAUTION

- The cabinet product is very heavy. Before moving to another location, confirm whether the ground load is in compliance.
- During the process of moving the cabinet, it is recommended that two or more people cooperate and push it slowly and at a constant speed. If you encounter a pit, you need to pay special attention. It is forbidden to push it quickly, otherwise it will easily cause excessive inertia and cause the casters at the bottom of the cabinet to jam and the cabinet to fall.
- It is not advisable to push down the slope to prevent the cabinet from falling down due to the shift of the center of gravity. It is recommended to use a forklift or crane to move the cabinet.
- ITECH 27U and 37U cabinets are equipped with hoisting rings as standard on the top. It is recommended to use a crane equipped with a four-leg hoisting belt structure for horizontal hoisting and moving, and ensure that the four hoisting belts are the same length to avoid cabinet skew during movement. As shown below.
- After moving to the destination, please lock the four casters to secure the cabinet.
- The cabinet should be placed on a level ground. It is forbidden to place the cabinet on a sloped ground.

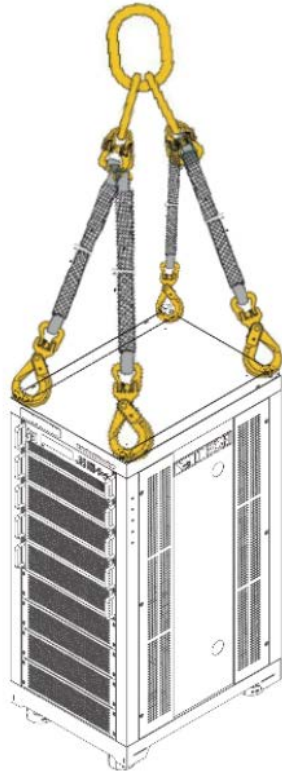

## 2.2 Verifying the Shipment

Open the package and check the articles within package box before operation. In case of any non-conformity, missing or appearance wearing, please contact ITECH immediately.

The package box should comprise:

Device name	Quantity	Model	Remarks
High-power DC Power Supply	x1	IT6600D series	For the specific models included in this series, refer to <a href="#">1.2 Models and Options</a> .
Power Cord	-	-	The 3U models come standard with one power cord; the 15U models come with one set of power cords; the 27U and 37U models each come with two sets of power cords.
USB communication cable	x1	-	This is used when the USB interface is used for starting up remote operation.
LAN communication cable	x1	-	This is used when the LAN interface is used for starting up remote operation.
Busbar Kits for Parallel-Series connection	x1	IT-E184	Used for connecting machines in series or parallel. (Standard on 3U models only.)
Calibration Report	x1	-	It is the calibration certificate of the instrument before delivery.

**NOTE**

After confirming that package contents are consistent and correct, please appropriately keep package box and related contents. The package requirements should be met when the instrument is returned to factory for repair.

## 2.3 Connecting the Power Cord

Connect power cord of standard accessories and ensure that the power supply is under normal power supply.

### Before connecting the power cord

To prevent electric shock and damage to the instrument, observe the following precautions.

**WARNING**

- Before connecting power cord, be sure to confirm that the power voltage matches with the rated input voltage of the instrument.
- Before connecting power cord, be sure to switch off the instrument. Verify that there is no dangerous voltage on the connection terminals.
- To avoid fire or electric shock, Make sure to use the power cord supplied by ITECH.
- Be sure to connect the power cord to the AC distribution box with protective grounding. Do not use terminal board without protective grounding.
- Do not use an extended power cord without protective grounding, otherwise the protection function will fail.
- Ensure that the power cord connection terminals are either insulated or covered by the supplied protective cover so that no accidental contact with lethal voltage can occur.

**CAUTION**

Safety agency requirements dictate that there must be a way to physically disconnect the AC mains cable from the unit. A disconnect device, either a switch or circuit breaker must be provided in the final installation. The disconnect device must be close to the equipment, be easily accessible, and be marked as the disconnect device for this equipment.

### Categories of Power Cords

- 3U instruments provides the standard power cords as below.

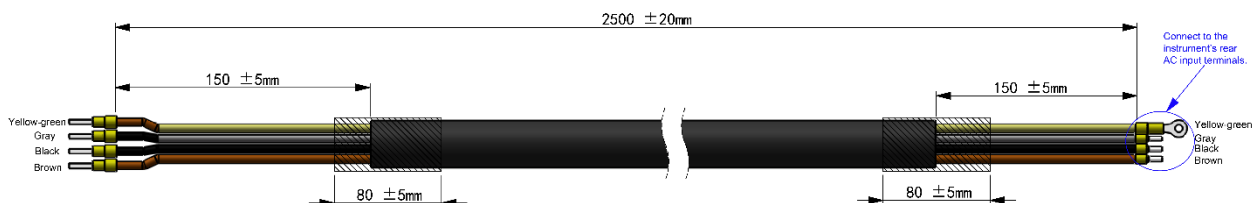

The yellow-green wire is grounding wire, which is connected to the PE terminal of power input on the rear panel; the others are live wires, which are correspondingly connected to the L1, L2 and L3 terminals of power input on the rear panel of the instrument.

The power cord specification for the 3U instruments is  $4 \times \text{AWG } 3 / 105^\circ\text{C}$  /

2500 mm.

- This series of 15U cabinets comes standard with one set, and the 27U and 37U cabinets come standard with two sets of 2.5-meter AC input power cords (each set contains four cords). Each cord is shown below.

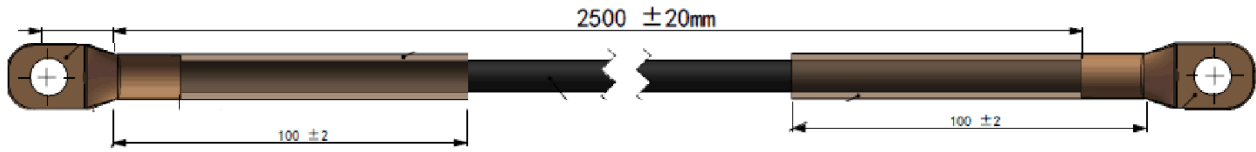

The yellow-green wire is grounding wire, which is connected to the PE terminal of power input on the rear panel; the others are live wires, which are correspondingly connected to the L1, L2 and L3 terminals of power input on the rear panel of the instrument.

The specifications of the power cords are shown in the table below.

Cabinet Height	Number of Power Cords (sets)	Cords Specification
15U	1 set	AWG 2 / 600V / 105°C, crimped with TLK35-10 terminals on both ends.
27U	2 sets	AWG 3/0 / 600V / 105°C, crimped with TLK95-10 terminals on both ends.
37U	2 sets	AWG 4/0 / 600V / 105°C, crimped with TLK120-10 terminals on both ends.



#### NOTE

The colors of the L1/L2/L3 cables vary by region; for example, in Europe, they are brown, black, and grey.

## AC Power Input Level

The AC input of this series is a three-phase AC power (three-phase four-wire) by default, the detailed specifications refer to Technical Specifications.

## Connecting the Power Cord

The AC input is three phase and balanced, connecting the power cord as below.

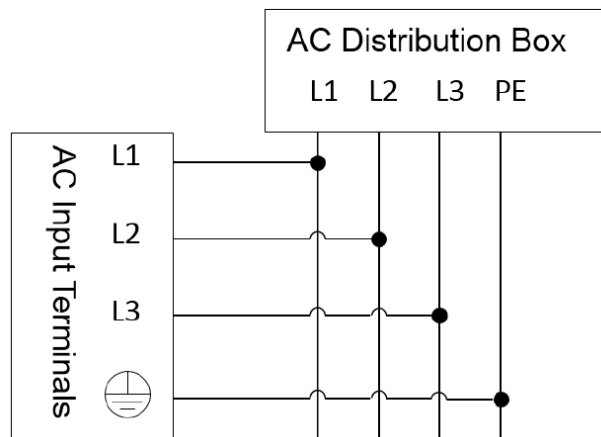

### Operation procedures:

1. Confirm that the switch of the AC power distribution box is off.
2. Confirm that the power switch is in the OFF position and verify that there is no dangerous voltage on the connection terminals.
3. Connect the end of the power cord with the round terminal (ground terminal) to the AC power input terminal on the rear panel of the instrument.
  - a) You only need to connect the brown/black/gray live wires to the terminals on the rear panel, which are not required to correspond to L1, L2 and L3 terminals one by one.
  - b) The yellow-green wire is grounding wire, which is connected to the protective grounding terminal (PE).

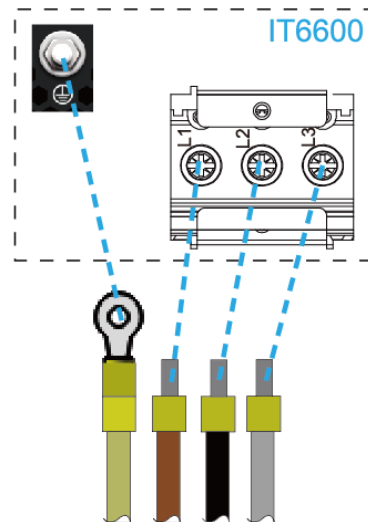

4. Refer to the suggestion connection diagram, connect the other end of the power cord to the required AC distribution box.

Connect the 2 sets of power cords for the 27U/37U models to the AC distribution box.

## 2.4 Connecting Test Lines ( Optional)

Test lines are not standard accessories of the instrument. Please select optional red and black test lines for individual sales based on the maximum current value. For specifications of test lines and maximum current values, refer to “**Specifications of Red and Black Test Lines**” in “**Appendix**”.

### WARNING

- Before connecting test lines, be sure to switch off the instrument. Power switch is in Off position. Otherwise, contact with output terminals in rear panel may cause electrical shock.
- To avoid electrical shock, before testing, please make sure the rating values of the testing lines, and do not measure the current that higher than the rating value. All test lines shall be capable of withstanding the maximum short circuit output current of the power supply without causing overheat.
- If several loads are provided, each pair of load wires shall safely withstand the rated short circuit output current of the power supply under full load.

- Always use test lines provided by ITECH to connect the equipment. If test lines from other factories are used, please check that the test line can withstand maximum current.

## Specification for Test Cables

Test cables are not standard accessories for the instrument. Please select optional red and black test cables for individual sales based on the maximum current value. For specifications of test cables and maximum current values, refer to [Specifications of Red and Black Test Cables](#) for more information.

## Electrode introduction

The wiring apertures on the DC electrodes of the 3U model and the cabinet model are both **M8**.

## Connecting the DUT (Local Measurement)

The instrument supports two kinds of wiring methods with the DUT: local measurement and remote measurement (SENSE). The default test mode is local measurement.

Please confirm that the Remote Sense function in the menu is set to Off, otherwise the instrument will report an error in the present connection mode.

The connection diagram and steps of local sensing are as follows.

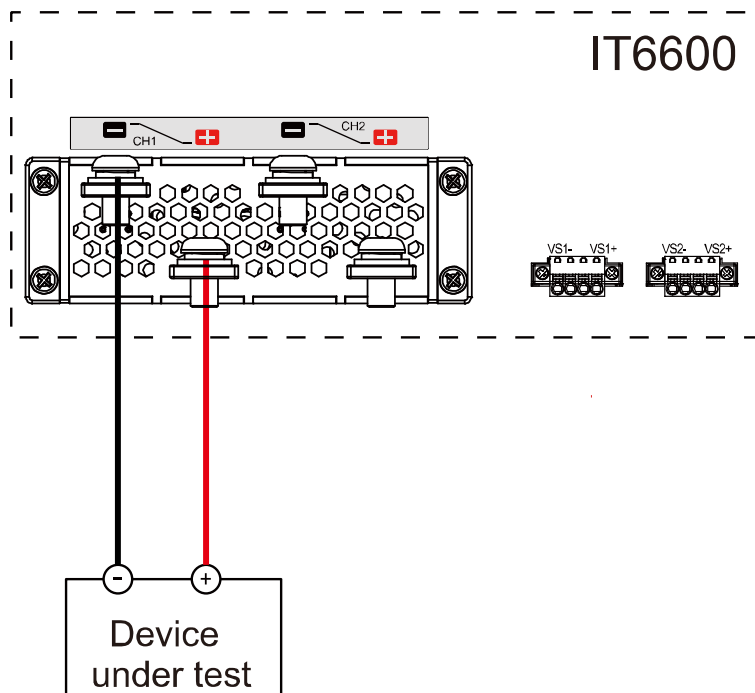

1. Confirm that the power switch is in the OFF position and verify that there is no dangerous voltage on the connection terminals.
2. Remove the output terminals cover of the power system.
3. Loosen the screws of the output terminals and connect the red and black test cables to the output terminals. Re-tighten the screws.

When maximum current that one test cable can withstand fails to meet the rated current, use multiple pieces of red and black test cables. For example, the maximum current is 1,200A, then 4 pieces of 360A red and black cables

are required.

4. Thread the red and black test cables through the output terminals cover of the power system and install the cover.
5. (Optional) According to the actual situation of DUT, connect the grounding terminal on the rear panel of the instrument to the DUT to ensure the safe grounding.

For the location information, see 1.5 Rear Panel.

6. Connect the other end of the red and black cables to the DUT. The positive and negative poles must be properly connected and fastened when wiring.

## Connecting the DUT (Remote Sensing)

Remote measurement is available for the following scenarios:

When the DUT consumes large current or the wires are too long, there is a voltage drop on the wires between DUT and output terminals of the power system.

To maximize measurement accuracy, the power system provides the remote measurement terminals VS+ and VS- on the rear panel, which can be used to measure the terminal voltage of the DUT.

When the power system is used for battery testing in actual applications, the voltage drop of the wire will lead to voltage inconsistency of both ends and inconsistency of the cutoff voltage of power system and the actual voltage of battery, resulting in inaccurate measurement.

The connection diagram and steps of remote measurement are as follows:

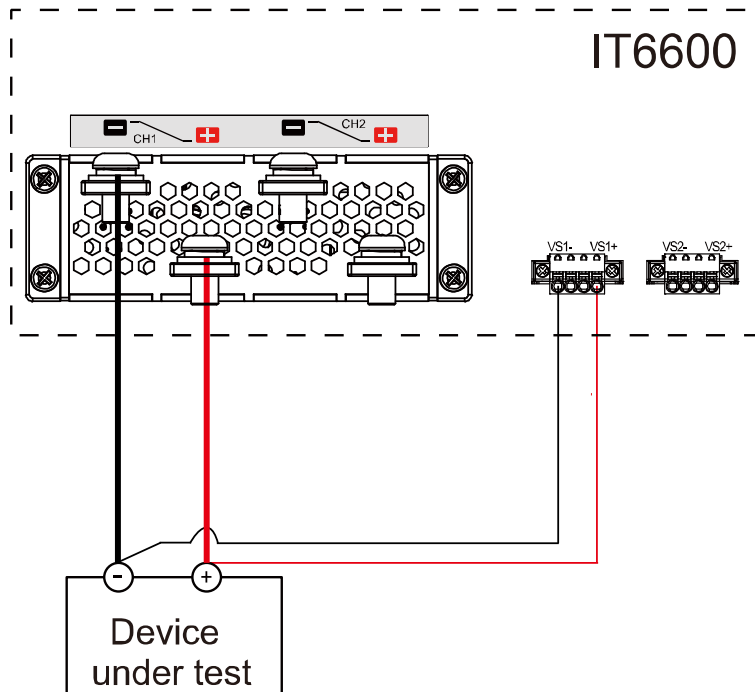

1. Confirm that the power switch is in the OFF position and verify that there is no dangerous voltage on the connection terminals.
2. Remove the output terminals cover of the power system.
3. Refer to the wiring diagram and connect the Vs+ and Vs- with armored twisted-pair cables. Loosen the screws of the output terminals and connect the red and black test cables to the output terminals. Re-tighten the screws.

When maximum current that one test cable can withstand fails to meet the rated current, use multiple pieces of red and black test cables. For example, the maximum current is 1,200A, then 4 pieces of 360A red and black cables are required.

4. Thread the red and black test cables through the output terminals cover of the power system and install the cover.
5. (Optional) According to the actual situation of DUT, connect the grounding terminal on the rear panel of the instrument to the DUT to ensure the safe grounding.

For the location information, see [1.5 Rear Panel](#).

6. Connect the other end of the remote sense cables to the DUT.
7. Connect the other end of the red and black cables to the DUT. The positive and negative poles must be properly connected and fastened when wiring.
8. Power on the instrument and turn on the **Remote Sense** function of the instrument.

---

## Chapter3 Getting Started

---

### 3.1 Power-on the Instrument

A successful selftest indicates that the purchased power product meets delivery standards and is available for normal usage.

Before operation, please confirm that you have fully understood the safety instructions.

#### Precautions

To prevent electric shock and damage to the instrument, please observe the following precautions.

#### WARNING

- Before connecting power cord, be sure to confirm that the power voltage matches with the supply voltage.
- Before connecting power cord, be sure to switch off the instrument. Verify that there is no dangerous voltage on the terminals before touching them.
- To avoid fire or electric shock, make sure to use the power cord supplied by ITECH.
- Be sure to connect the main power socket to the power outlet with protective grounding. Do not use terminal board without protective grounding.
- Do not use an extended power cord without protective grounding, otherwise the protection function will fail.
- Ensure that the input electrodes are either insulated or covered using the safety covers provided, so that no accidental contact with lethal voltages can occur.
- If you notice strange sounds, unusual odors, fire, or smoke around or from inside the instrument, flip the POWER switch to the (O) side to turn the instrument off, or remove the power cord plug from the outlet. The detachable power cord may be used as an emergency disconnecting device. Removing the power cord will disconnect AC input power to the unit.

---

#### CAUTION

Safety agency requirements dictate that there must be a way to physically disconnect the AC mains cable from the unit. A disconnect device, either a switch or circuit breaker must be provided in the final installation. The disconnect device must be close to the equipment, be easily accessible, and be marked as the disconnect device for this equipment.

---

## Power Switch Introduction

User can adjust the switching knob directly to turn on or turn off the device. The status of switching knob is as follows.

When the switching knob is in the OFF position, it can be rotated 90 degrees clockwise to power on the device; when the switching knob is in the ON position, it can be rotated 90 degrees counterclockwise to power off the device.



## Turning the POWER Switch On

Check that the power cord is connected properly.

Flip the POWER switch to the ( ON ) side to turn the instrument on. The front panel display will light up after a few seconds. It may take about 30 seconds or so for the power supply to initialize before it is ready for use.

If a self-test error occurs, an error message will be displayed in the front panel. Press the **[Esc]** button to try to clear the current fault status. The user can also restart the instrument to try to clear the fault status. Wait until the power is turned off and then start again. If the problem still cannot be solved after restarting, please contact the ITECH engineer.

## Turning the POWER Switch Off

Flip the POWER switch to the ( OFF ) side to turn the instrument off. When it is turned off, the instrument interface will prompt "Please wait for the device power down.", and the instrument will store the setting information before shutdown in the group 1 nonvolatile memory.

After you turn the POWER switch off, wait at least 10 seconds after the fan stops before you turn the POWER switch back on. Turning the instrument on too soon after you turn it off can cause damage to the inrush current limiter circuit, as well as reduce the life of components such as the POWER switch and the internal input fuses.

## 3.2 Touch Screen Introduction

This series of power display is a touch screen LCD interface, users can select and set parameters by hand touch. The touch function can be set in the system menu.

This parameter determines the state of the touch screen.

1. Press the **General** under the system menu.
2. Press the Up/Down key or turn the knob to select the **Touch Function** and press **[Enter]**.
  - On: enable touch function.
  - Off: disable touch function.

### 3.3 Set output parameters

The voltage value and current value can be programmed, which can be set to different parameters within the specification range based on customer requirements. This can meet various test requirements of the customer.

After the user presses the **[V-set]** or **[I-set]** keys on the front panel, the instrument interface displays the parameters to be set and the cursor flashes for prompt. The user can use the following methods to set the values.

- Directly use the number keys to set the value.
- Rotate the knob to set the data in the cursor position. Rotate the knob lockwise to increase the set value and anticlockwise to decrease the set value. Once the data in the cursor position increases to ten, the value will add one to the front position automatically. and once the data in the cursor position decreases to zero, the value will minus one from the front position automatically. This provides convenience for the user to set. The knob can works with the left or right keys. Use the left or right keys to move the cursor position.

 **NOTE**

After entering the menu interface, the knob can also be used to scroll pages to view menu items.

### 3.4 Output On/Off Control

**WARNING**

- The **[On/Off]** key is used to turn the output on or off under normal circumstances. Even if the instrument is in control by PC or the keyboard is locked, the **[On/Off]** is still valid.
- The **[On/Off]** key light is off and turning the output off does not place the instrument in a safe state. Hazardous voltages may be present on all output and guard terminals. Putting the equipment into an output-off state does not guarantee that the outputs are powered off if a hardware or software fault occurs. See the cautions about connecting the test lines before connecting test lines.

#### Controlled by the **[On/Off]** key

User can control the output switching of the instrument's 2 channels by pressing the **[CH1 On/Off]** key and the **[CH2 On/Off]** key on the front panel. If the **[On/Off]** key light is on, indicates that the output is turned on. The meter area on the interface will display the voltage, current, and power values in the current circuit. If the **[On/Off]** key light is off, indicates that the output is turned off. The LCD displays that the power supply state is OFF.

#### Controlled by Digital IO pins

The Digital IO pin, which comes standard with this series of instruments, supports external level/pulse signal control output, and in combination with external circuitry, enables emergency stop control of the output. Refer to the following use case.

**Case:**

Pin 5 of Digital IO has an INTERLOCK function. In the default settings of **Reverse (Off)** and **Inhibit-Living**, pulling pin 5 low (0V) can disable the machine's output. At this point, the **[On/Off]** key light is on, but there will be no

actual output. Restoring pin 5 to a high level will resume normal output from the machine.

1. Go to the **System**→**IO**→**Digital IO-5 Settings** menu.
2. Select the **Reverse(Off)** and **Inhibit-Living** items, and press [Enter] to confirm.
3. Connect Pin5 (positive) and Pin8 (negative) of Digital IO to the external signal control circuit.

At this time, 5V is output between Pin5 and Pin8.

4. After connecting the DUT, turn on [**On/Off**].
5. Input 0V to Pin5 (positive) and Pin8 (negative), or directly short Pin5 and Pin8.

At this point, output is disabled.

6. Input 5V to Pin5 (positive) and Pin8 (negative), or disconnect the short wire between Pin5 and Pin8.

At this point, output is restored.

## Chapter4 Power Supply Function

This chapter describes the functions and features of the power supply.

### 4.1 Output Function

#### 4.1.1 Set the Output Mode

The IT6600 series power supply supports DC output mode. The output mode can be select in the config menu.

1. Press the composite keys **[Shift] + [V-set]** (Config) on the front panel to enter the config menu.
2. Press the up/down key or rotate the knob to find **Output Couple Mode** menu.
  - i. Press the up/down key to move the cursor to the Mode function setting and press the **[Enter]** key to confirm. Rotate the knob to set DC output mode, and press the **[Enter]** key to confirm.
3. Press **[Esc]** to exit.

#### DC Mode

When the DC is turned on, it indicates that the instrument serves as a DC power supply. Under this mode, the instrument will generate DC output. The default set of IT6600 series power supply is DC Mode.

#### Set the Output Voltage/Current/Power

- In CV priority (default) mode, the main interface displays Vset (Setting value of voltage), Ilimit (Upper limit of current), and Plimit (Upper limit of power).
- In CC priority mode, the main interface displays Iset (Setting value of current), Vlimit (Upper limit of voltage), and Plimit (Upper limit of power).

Press the up/down key to move the cursor to the **parameters** setting and press the **[Enter]** key to confirm. Press numeric keys or rotate the knob to adjust the value in the current setting area. This value takes effect when you press **[Enter]**.

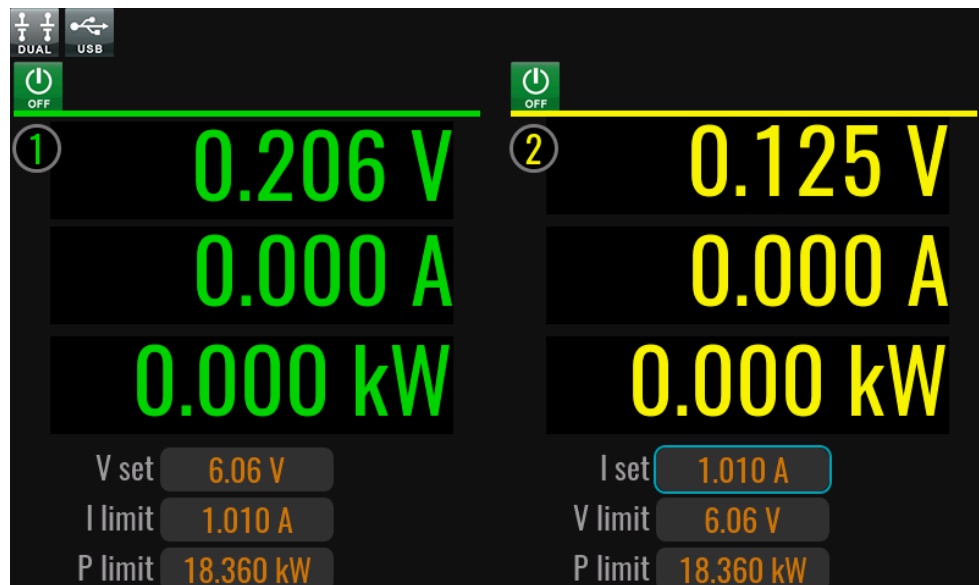

## 4.1.2 Set the Output Priority Mode

### CV Priority

In CV priority mode, the output is controlled by a constant-voltage feedback loop, which maintains the output voltage at its programmed setting as long as the load current remains within the current limit settings. CV priority mode is best suited for use with resistive or high impedance loads, and loads that are sensitive to voltage overshoots. Do not use CV priority mode with low-impedance sources such as batteries, power supplies, or large charged capacitors.

In CV priority mode, the output voltage should be programmed to the desired value. A current limit value should also be set. The current limit should always be set to a value that is greater than the actual input current requirement of the external load. The following figure shows the CV priority operating locus of the output.

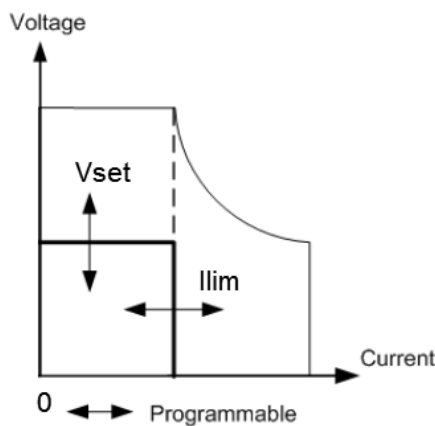

The heavy solid line illustrates the locus of possible operating points as a function of output. As shown by the horizontal portion of the line, the output voltage remains regulated at its programmed setting as long as the load current remains within the current limit setting. A CV status flag indicates that the output voltage is being regulated and the output current is within its limit settings.

Note that when the output current reaches current limit, the unit no longer operates in constant voltage mode and the output voltage is no longer held constant. Instead, the unit will now regulate the output current at its current limit setting.

### CC Priority

In CC priority mode, the output is controlled by a constant current feedback loop, which maintains the output current at its programmed setting. The output current remains at its programmed setting, provided the load voltage remains within the voltage limit setting. CC priority mode is best suited for use with batteries, power supplies, large charged capacitors, and loads that are sensitive to current overshoots.

In CC priority mode, the output current should be programmed to the desired value. A positive voltage limit range should also be set. The voltage upper limit should always be set to a value that is greater than the actual input voltage requirement of the external load. The following figure shows the CC priority operating locus of the output.

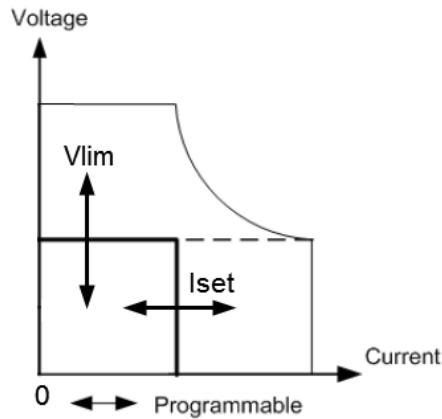

The heavy solid line illustrates the locus of possible operating points as a function of output. As shown by the vertical portion of the line, the output current remains regulated at its programmed setting as long as the output voltage remains within its limit setting. A CC (constant current) status flag indicates that the output current is being regulated and the output voltage is within its limit settings.

Note that when the output voltage reaches the upper limit, the unit no longer operates in constant current mode and the output current is no longer held constant. Instead, the unit will now regulate the output voltage at its voltage limit setting.

## How to Set

The procedures to set the output priority mode are as follows.

1. Press the composite keys **[Shift] + [V-set]** (Config) on the front panel to enter the config menu.
2. Press the up/down key or rotate the knob to find **Priority Mode** menu.
  - i. Press the up/down key to move the cursor to the Mode function setting and press the **[Enter]** key to confirm. Rotate the knob to set CC priority or CV priority, and press the **[Enter]** key to confirm.
  - ii. Press the up/down key to move the cursor to the **Loop Speed** function setting and press the **[Enter]** key to confirm. Use the numeric keys to set CC or CV loop response speed, and press the **[Enter]** key to confirm.
3. Press **[Esc]** to exit.

### 4.1.3 Set Output Slew

This series instrument is supported setting the V-Rise/V-Fall under CV priority mode and I-Rise/I-Fall under CC priority mode. The slew is the time for one voltage/current point to rise/fall to the other point under the output status is ON.

This series instrument offers two types of slew modes: time slew and standard slew. The standard slew is influenced by series and parallel connections. Please refer to the table below for the relevant slew parameters.

Slew	Priorty mode	Unit	Minimum value	Maximum value (Num is the number of instruments connected in parallel or series.)	Default value
Time	CV	ms	0.2ms	-	100ms

	CC	ms	0.2ms	-	100ms
Standard	CV	V/ms	-	<ul style="list-style-type: none"> <li>● Parallel &amp; Dual Channel: <math>V_{max}/0.2ms</math></li> <li>● Series: <math>V_{max}/0.4ms</math></li> </ul>	$V_{max}/100ms$
	CC	A/ms	-	<ul style="list-style-type: none"> <li>● Parallel: <math>I_{max}/(0.4ms*Num)</math></li> <li>● Series &amp; Dual Channel: <math>I_{max}/(0.2ms*Num)</math></li> </ul>	$I_{max}/100ms$

The instrument displays different slew parameters according to present CC or CV priority.

- When CV priority mode: displays V-Rise and V-Fall.
- When CC priority mode: displays I-Rise and I-Fall.

**The following takes the CV priority mode as an example to introduce the operation of setting slew, the setting method under CC priority mode is the same.**

1. Press the composite keys **[Shift] + [V-set]** (Config) on the front panel to enter the config menu.
2. Press the up/down key or rotate the knob to find **Priority Mode** menu.
  - i. Press the up/down key to move the cursor to the Mode function setting and press the **[Enter]** key to confirm. Rotate the knob to select the CV priority and press the **[Enter]** key to confirm.
  - ii. Press the up/down key to move the cursor to the **Loop Speed** function setting and press the **[Enter]** key to confirm. Use left and right keys and knob to setting the CV loop response speed and press **[Enter]** to confirm.
3. Press the up/down key or rotate the knob to find **Slew Config** menu.
  - i. Press the up/down key to move the cursor to the **Mode** function setting and press the **[Enter]** key to confirm. Rotate the knob to select the slew unit and press the **[Enter]** key to confirm.
  - ii. Press the up/down key to move the cursor to the **V-Rise** function setting and press the **[Enter]** key to confirm. Use left/right keys and knob to setting the voltage rise slew and press **[Enter]** to confirm.
  - iii. Press the up/down key to move the cursor to the **V-Fall** function setting and press the **[Enter]** key to confirm. Use left/right keys and knob to setting the voltage fall slew and press **[Enter]** to confirm.
4. Press **[Esc]** to exit.

#### 4.1.4 Set the Internal Resistance

This series instrument provides internal resistance setting (CV priority mode only). The procedures are shown as below.

1. Press the composite keys **[Shift] + [V-set]** (Config) on the front panel to enter the config menu.
2. Press the up/down key or rotate the knob to find **Output Resistance** menu.
  - i. Press the up/down key to move the cursor to the **Level** function setting and press the **[Enter]** key to confirm. Use the numeric keys to set the internal resistance value and press **[Enter]** to confirm.
3. Press **[Esc]** to exit.

### 4.1.5 Set the Output-On/Output-Off Delay

You can set the output-on/output-off delay time within the range from 0 seconds to 60 seconds.

- On Delay+Offset: Indicates from the time that a command to turn on the output is received until the output actually turns on.
- Off Delay+Offset: Indicates from the time that a command to turn off the output is received until the output actually turns off.

The procedures to set the output delay time are as follows.

1. Press the composite keys **[Shift] + [V-set]** (Config) on the front panel to enter the config menu.
2. Press the up/down key or rotate the knob to find **Onoff Delay** menu.
  - i. Press the up/down key to move the cursor to the **On Delay** function setting and press the **[Enter]** key to confirm. Use the numeric keys to set the on delay time and press the **[Enter]** key to confirm.
  - ii. Press the up/down key to move the cursor to the **Off Delay** function setting and press the **[Enter]** key to confirm. Use the numeric keys to set the off delay time and press the **[Enter]** key to confirm.
3. Press **[Esc]** to exit.

### 4.1.6 Enable the Output

User can control the output switching of the instrument's 2 channels by pressing the **[CH1 On/Off]** key and the **[CH2 On/Off]** key on the front panel. When receive the On/Off command, the instrument enable or disable the output according to the On/Off delay time. If the On/Off delay time set to 0, the source enable or disable output immediately. Detailed information of On/Off delay time refers to [4.1.5 Set the Output-On/Output-Off Delay](#).

- When **[On/Off]** key is lit, indicates the output is enabled, the LCD displays source present run mode.
- When **[On/Off]** key is lit, indicates the output is disabled, the LCD displays source state is OFF.

## 4.2 Protection Function

Press **[Shift]+[Recall]** (Protect) and enter to **Protect** configure menu, where you can set the following protection.

Over Voltage Protection	OVP	
	Status	Configure over-voltage protection: On or Off.
	Level	OVP limit.
	Delay	Protection delay time.
Over Current Protection	OCP	
	Status	Configure over-current protection: On or Off.
	Level	OCP limit.
	Delay	Protection delay time.
Over Power Protection	OPP	
	Status	Configure over-power protection: On or Off.
	Level	OPP limit.
	Delay	Protection delay time.
Under Voltage Protection	UVP	
	Status	Configure under-voltage protection:

		On or Off.
	Warm up time	Indicates the instrument warm-up time.
	Level	UVP limit.
	Delay	Protection delay time.
Under Current Protection	UCP	
	Status	Configure under-current protection: On or Off.
	Warm up time	Indicates the instrument warm-up time.
	Level	UCP limit.
	Delay	Protection delay time.
Maximum Voltage Limit	Sets the maximum voltage value.	
	Level	The maximum voltage value.
Maximum Current Limit	Sets the maximum current value.	
	Output	The maximum output current value.
Maximum Power Limit	Sets the maximum power value.	
	Output	The maximum output power value.

### 4.2.1 Over Voltage Protection

Over-voltage protection function allows the user to enable the protection and set a over-voltage limit (Level) and delay time (Delay). The function is mainly used to protect the DUT connected during test to prevent it from damage due to over-voltage.

#### How to Set

1. Press **[Shift]+[Recall]** (Protect) keys and enter to Protection menu.
2. Press the up/down key or rotate the knob to select Over Voltage Protection.
3. Set the protection status, protection Level and the delay time in sequence, and press **[Enter]** to confirm.

#### Clear OVP Protection

When OVP protection occurs, the instrument responds as follows:

- Instrument output is off.
- The instrument emits an alarm sound every 3 seconds.
- The main interface status bar displays the OVP icon.

To clear the OVP and return to normal operation, firstly remove the conditions that caused the protection fault. Press **[Shift] +[Esc]** keys (or send the command PROTection:CLear) to clear the protection status. The message displayed in front panel is cleared and the instrument exits protection status.

### 4.2.2 Over Current protection

Over-current protection function allows the user to enable the protection and set a over-current limit (Level) and delay time (Delay). The function is mainly used to protect the DUT connected during test to prevent it from damage due to over load.

#### How to Set

1. Press **[Shift]+[Recall]** (Protect) keys and enter to Protection menu.
2. Press the up/down key or rotate the knob to select Over Current Protection and press **[Enter]**.

3. Set the protection status, protection Level and the delay time in sequence, and press [Enter] to confirm.

### Clear OCP Protection

When OCP protection occurs, the instrument responds as follows:

- Instrument output is off.
- The instrument emits an alarm sound every 3 seconds.
- The main interface status bar displays the OCP icon.

To clear the OCP and return to normal operation, firstly remove the conditions that caused the protection fault. Press **[Shift] +[Esc]** keys (or send the command PROTection:CLear) to clear the protection status. The message displayed in front panel is cleared and the instrument exits protection status.

### 4.2.2 Over Power protection

Over-power protection function allows the user to enable the protection and set a over-power limit (Level) and delay time (Delay). The function is mainly used to protect the DUT connected during test to prevent it from damage due to over load.

#### How to Set

1. Press **[Shift]+[Recall]** (Protect) keys and enter to Protection menu.
2. Press the up/down key or rotate the knob to select Over Power Protection and press [Enter].
3. Set the protection status, protection Level and the delay time in sequence, and press [Enter] to confirm.

### Clear OPP Protection

When OPP protection occurs, the instrument responds as follows:

- Instrument output is off.
- The instrument emits an alarm sound every 3 seconds.
- The main interface status bar displays the OPP icon.

To clear the OPP and return to normal operation, firstly remove the conditions that caused the protection fault. Press **[Shift] +[Esc]** keys (or send the command PROTection:CLear) to clear the protection status. The message displayed in front panel is cleared and the instrument exits protection status.

### 4.2.4 Under Voltage Protection

Users can enable the UVP function and set the instrument warm-up time (Warm up time), protection limit (Level) and protection delay time (Delay). When the voltage (i.e., the Meter value) is lower than this protection limit and the warm-up time, delay time are exceeded, the power supply will enter the UVP state.

#### How to Set

1. Press **[Shift]+[Recall]** (Protect) keys and enter to Protection menu.
2. Press the up/down key or rotate the knob to select Under Voltage Protection.
3. Set the protection status, warm up time, protection Level and the delay time in sequence, and press [Enter] to confirm.

## Clear UVP Protection

When UVP protection occurs, the instrument responds as follows:

- Instrument output is off.
- The instrument emits an alarm sound every 3 seconds.
- The main interface status bar displays the UVP icon.

To clear the UVP and return to normal operation, firstly remove the conditions that caused the protection fault. Press **[Shift] +[Esc]** keys (or send the command PROTection:CLEar) to clear the protection status. The message displayed in front panel is cleared and the instrument exits protection status.

## 4.2.5 Under Current Protection

Users can enable the UCP function and set the instrument warm-up time (Warm up time), protection limit (Level) and protection delay time (Delay). When the current (i.e., the Meter value) is lower than this protection limit and the warm-up time, delay time are exceeded, the power supply will enter the UCP state.

### How to Set

1. Press **[Shift]+[Recall]** (Protect) keys and enter to Protection menu.
2. Press the up/down key or rotate the knob to select Under Current Protection.
3. Set the protection status, warm up time, protection Level and the delay time in sequence, and press **[Enter]** to confirm.

## Clear UCP Protection

When UCP protection occurs, the instrument responds as follows:

- Instrument output is off.
- The instrument emits an alarm sound every 3 seconds.
- The main interface status bar displays the UCP icon.

To clear the UCP and return to normal operation, firstly remove the conditions that caused the protection fault. Press **[Shift] +[Esc]** keys (or send the command PROTection:CLEar) to clear the protection status. The message displayed in front panel is cleared and the instrument exits protection status.

## 4.2.6 Set Maximum Voltage/Current/Power Limit

The voltage output can be adjusted between 1% and 100% of  $V_{max}$ , while the current output and power output can be adjusted between 0% and 100%. You can set upper limits for the output voltage, current, and power in the Protection menu.

Limit factory setting is the rated output voltage/current/power of corresponding model of the power supply.

Take the voltage limit setting for an example, the operating as follows:

1. Press **[Shift]+[Recall]** (Protect) keys and enter to Protection menu.
2. Press the up/down key or rotate the knob to select Maximum Voltage Limit and press **[Enter]**.
3. Set the maximum Voltage limit, and press **[Enter]** to confirm.

## 4.2.7 Over-temperature protection (OTP)

When the temperature of the power component in the power supply exceeds 95°C, the temperature protection will be enabled. In this case, the power supply will be automatically OFF, and the LCD will display OTP icon. At the same time,

the OT position in the status register will be set and kept until power supply is reset.

#### Clearing over-temperature protection:

When the power supply temperature decreases to the protection temperature, press **[Shift]+[Esc]** keys on the front panel (or send the command "PROTection:CLEAr"). Then OTP on the power supply screen will disappear, and the power supply will exit the OTP status.

### 4.2.8 Sense Reverse Protection

The instrument defaults to provide sense reverse protection. The premise is that the Sense switch is turned on. When the output state is ON and the difference between output terminal voltage and sense remote voltage exceeds the sense compensation voltage, sense reverse protection will be enabled after 500ms. The power supply output will be immediately switched to Off and the buzzer will



sound if the sense terminals are reversed. The display screen will display . Press **[Shift]+[Esc]** keys (or send the command "PROTection:CLEAr") to clean the protection.

When the power source is in Sense Reverse Protection state, you should check the whether the polarities are connected reversely or not firstly. When the polarities connect correctly, please press **[On/Off]** button. Then the unit could have a output voltage again.

## 4.3 LIST Function

The user can edit the test procedure composed of several steps with the List function. With List function, a maximum of 100000 steps can be configured for each List file. The user needs to edit the voltage/current value, slope and duration of each step, and set certain repeated number of times and final state for each List file. After the file is edited completely, you can trigger the selected List file to run according to the selected trigger mode.

### Introduction of List interface

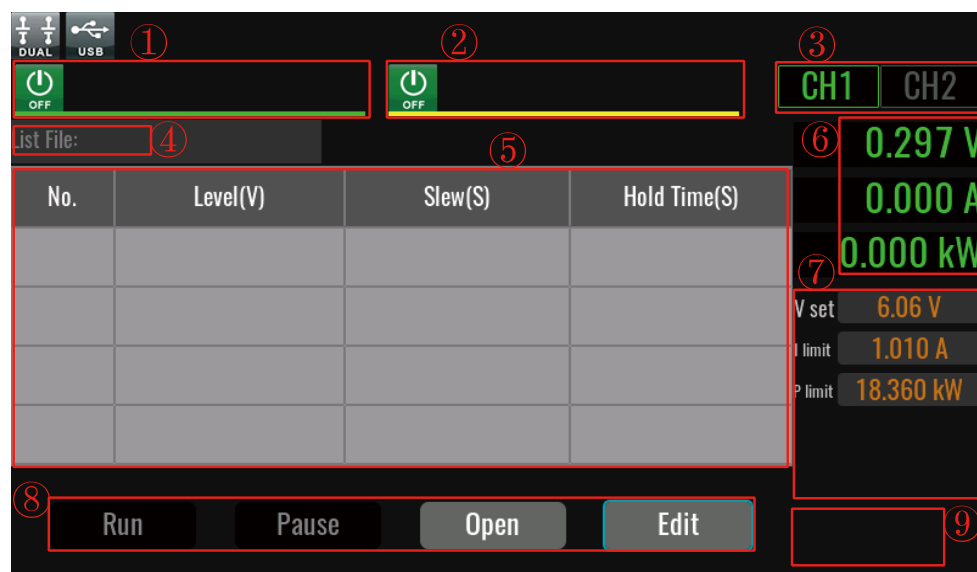

1. CH1 status bar: displays the output status of power channel 1.
2. CH2 status bar: displays the output status of power channel 2.

3. CH1/CH2: channel selection, Channel 1 or Channel 2.
4. 7.csv: the list file name to execute.
5. List display area: this area mainly displays the edited List, you can view this list by sliding up and down.
6. Output values view area: displays the output voltage value, output current value and output power value of the current channel.
7. Setting values view area (Normal mode): When CV is prioritized, the voltage setting value, current upper limit value, and power upper limit value are displayed. When CC is prioritized, the current setting value, voltage upper limit value, and power upper limit value are displayed.
8. List edit button. The functions are described as follows.
  - Run/Stop: run/stop the list function.
  - Pause: suspend list running. Resume: continue to run the list.
  - Open: select the List file to execute.
  - Edit: edit present list file.
9. Displays the List function relevant parameters, which can be viewed by sliding up and down.
  - Priority Mode: list running priority mode.
  - Slew Mode: slew unit.
  - Repeat Num: X/Y, X indicates the current number of cycles and Y indicates the total number of cycles.
  - Tout: trigger output setting.
  - End Mode: end state setting.
  - Current Step: A/B, A indicates the number of current running steps and B indicates the total number of steps.
  - RunState
  - RunTime

## Edit List files

The following takes CV priority mode as an example to introduce the operation of editing three test steps.

1. Press **[Shift]+[I-set]**(List) on the front panel to enter the List function main interface.
2. Click the **[Edit]** key on the screen and enter to the List file edit interface.

List edit
CH1

Description: null

Priority Mode: **CV**   Repeat: **Count**   **1**   Trig Out: **Off**

Slew Mode: **Time**   End Mode: **Off**   Trig Source: **Immediate**

No.	Level(V)	Slew(S)	Hold Time(S)
1			

Save
Config
Clear All

List parameters description:

Parameter	Description
Description	Description of List, display list file name.
Edit the attribute parameters of List file.	
Priority Mode	List running priority mode.
Repeat	Edit the cycles of the List file. You can choose Infinite and Count, when you choose Count, you also need to set the total number of loops, set the range: 1-9999999.
Trig out	Function switch that triggers the signal output. <ul style="list-style-type: none"> <li>● Off: Turn off.</li> <li>● On: Turn on. When IO-4 is configured as Trigger-out, a pulse signal will be output from IO-4 when triggering the List function.</li> </ul>
Slew Mode	Select the slew unit. <ul style="list-style-type: none"> <li>● Time: describe the slew of the device in terms of time.</li> <li>● Standard: standard slew, unit is V/ms or A/ms.</li> </ul>
End Mode	Set the final waveform, with the following options available: <ul style="list-style-type: none"> <li>● Off: directly off the output after operation.</li> <li>● Normal: return to normal after operation.</li> <li>● Last: keep the last waveform output unchanged after operation.</li> </ul>
Trig Source	Select the trigger source for running this list file. <ul style="list-style-type: none"> <li>● Immediate: Perform a trigger operation immediately.</li> <li>● Manual: Indicates the trigger occurs when the <b>[Shift]+[5]</b>(Trigger) keys are pressed from the front panel.</li> <li>● Bus: Bus trigger. When the trigger command <b>*TRG</b> is received, the instrument generates a trigger.</li> <li>● External: Indicates the trigger occurs via the pin 4 of the digital I/O interface (P-IO). For details, see <a href="#">5.9 Digital I/O Function</a>.</li> </ul>

Edit the step parameters of List file.	
No.	Step number of list. Click the number, you can operate such as copy/paste/cut/insert/delete.
Level	Voltage value/current value.
Slew	Slew value.
Hold Time	Width time. The range is from 0.001 to 21000 in seconds.
Save	Save the list file.
Config	Configure the list file to make it effective.
Clear all	Delete all of step information.

- Fill in corresponding parameter in the List file edit interface and press **[Save]**.  
At list Edit interface, click the step number, the **[Copy]/[Paste]/[Cut]/[Insert]/[Delete]** will display, click the key to edit.
- Press **[Esc]**, and return to the List function interface. The List display zone displays the edited List file.

### Select/Run List File

If several List files are edited, press **Open** to recall the List file to be tested. Detailed operation steps are as below:

- Press **[Shift]+[I-set](list)** on the front panel to enter the List function main interface.
- Click the **[Open]** key on the screen, select the saved 7.csv file, and click the **[Open]** key to enter the file.
- Press **[On/Off]** on the front panel, turn on the output.
- Press **[Run]** key in the list function interface.
- Based on the selected trigger method, perform the trigger operation.

Take the manual trigger as an example. Press **[Shift]+[5](Trigger)** on the front panel to run the selected List file.

### Stop Running the List Program

When the List program is running, if you click **Stop**, it means to stop the present running, and you can wait for the next trigger to run; if you click **Pause**, it means that the present running is suspended, and you can continue to run by click **Resume**.

### Import/Export List file

- **Import List file**

IT6600 series support import list file function, the user can finish the editing of List file in Excel and import it into the software. This function simplifies the List file edit and facilitates user operation.

To help user define an Excel file format, please export a CSV template from the List interface.

Detailed operation steps are as below:

- Create a new Excel document on local PC and name it 5.csv.
- Open the Excel document and save it as in "other formats" i.e. "(\*.csv)".
- Open the 5.csv document and edit the List. Set every step of the List

and corresponding parameters and save the document in the USB disk.

	A	B	C	D	E
1	Model	IT6600			
2	Version	123			
3	File Type	List			
4	Priority	McCV			
5	Repeat	Mc Count			
6	Repeat Co	2			
7	End	OFF			
8	Slew Mode	Standard			
9	Trig Source	Manual			
10	Trig Out	OFF			
11	Step total	3			
12	Step Index	Level(V)	Slew(V/ms)	Keep Time(S)	
13	1	5	1	5	
14	2	7	1	5	
15	3	3	1	5	
16					

- The list files for dual-channel output mode and parallel output mode need to be placed in the listParallel folder of the USB flash drive.
- The list file for serial output mode needs to be placed in the listSeries folder on the USB flash drive.

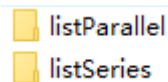

4. Insert the USB disk into the USB interface of the front panel. Press **[Shift]+[I-set]**(List) on the front panel to enter the List function main interface.
  5. Click the **[Open]** key on the screen, enter to list recall interface.
  6. Click usb, select the 5.csv file in the usb, and click **[Open]** to confirm. The list file will be imported and the configured 5.csv file will appear in the interface.
- **Export List file**

After editing the List file, the user can directly save it into the device or export and save it into the peripheral memory disc. The exported List is saved in the format of. (\*.csv). Detailed operation steps are as below:

1. Insert the U disk into the USB interface of the front panel. (The USB type needs to be set as Host.)
2. Press **[Shift]+[I-set]**(List) on the front panel to enter the List function main interface.
3. Click the **[Edit]** key on the screen, enter to list file edit interface.
4. Click the **[Save]** key to enter the list save interface.
5. Click usb, set the FileName of the exported file, and click **[Save]** to confirm the export. Then you can export the list file from Edit interface to USB disk.

### 4.3.1 ARB Function

This series of instruments comes standard with ARB (arbitrary waveform) function, which allows the output of user-defined arbitrary complex voltage or current waveforms. It can be operated in the following ways:

## Import via U disk

The instrument supports importing the edited .csv format file (the template can be obtained by contacting ITECH personnel) through the USB interface on the front panel, and generating voltage or current values after parsing, and then outputting complex voltage or current waveforms according to the time width specified by the user. The user can edit a .csv file containing up to 80 million voltage or current points and import it into the instrument for running to realize arbitrary waveform output or working condition simulation.

The instrument has the ability to quickly parse data. A .csv file of dozens of megabytes can be imported and parsed within 5S, making testing more convenient and efficient.

This instrument supports importing the .csv files corresponding to the following waveforms:

- **CDWELL: Constant dwell arbitrary waveform**

The fields included in the .csv template file are explained as follows:

Model	Device model, keep the default settings without modification.
Firmware Version	Firmware version number, keep the default settings without modification.
Serial Number	Device serial number, keep the default settings without modification.
File Type	File type, keep the default settings without modification.
Waveform Type	Waveform type, keep the default settings without modification.
Value Unit	The CV priority is set to V, and the CC priority is set to A.
Offset Unit	Offset value unit, CV priority is set to V, CC priority is set to A.
Time Unit	Time unit, fixed to S.
Mode	Indicates the power supply working mode. The CV priority is set to CV, and the CC priority is set to CC.
Repeat	Repeat times, the setting range is 1~65535.
End State	Indicates the end state. Last (voltage or current maintained at the last point after completion) or Normal (return to the mode before CDWELL execution after completion).
Total Point	The total number of waveform points.
Keep Time	Indicates the pulse width of each point. Range: 0~3600. Unit: seconds.
Value	Voltage or current value at each point.

- List: User-defined waveform

The fields included in the .csv template file are explained as follows:

Model	Device model, keep the default settings without modification.
Firmware Version	Firmware version number, keep the default settings without modification.
Serial Number	Device serial number, keep the default settings without modification.
File Type	File type, keep the default settings without modification.
Waveform Type	Waveform type, keep the default settings without

	modification.
Value Unit	The CV priority is set to V, and the CC priority is set to A.
Slope Unit	Slope unit, fixed to S.
Time Unit	Time unit, fixed to S.
Mode	Indicates the power supply working mode. The CV priority is set to CV, and the CC priority is set to CC.
Step Count	The total number of steps, up to 10 million points can be edited.
Repeat	Repeat times, the setting range is 1~65535.
End State	Indicates the end state. Last (the voltage or current maintained at the last step after the end) or Normal (return to the normal mode before the List is executed after the end).
Step Index	The sequence number of the single step.
value	Voltage or current value for a single step.
slope	Slope for a single step.
Keep Time	Pulse width for a single step.

- **Sine: Sine wave**

The fields included in the .csv template file are explained as follows:

Model	Device model, keep the default settings without modification.
Firmware Version	Firmware version number, keep the default settings without modification.
Serial Number	Device serial number, keep the default settings without modification.
File Type	File type, keep the default settings without modification.
Waveform Type	Waveform type, keep the default settings without modification.
Amp Unit	Peak-to-peak unit, CV priority is set to V, CC priority is set to A.
Offset Unit	Offset value unit, CV priority is set to V, CC priority is set to A.
Frequency Unit	Frequency unit, Hz.
Mode	Indicates the power supply working mode. The CV priority is set to CV, and the CC priority is set to CC.
Repeat	Repeat times, the setting range is 1~65535.
Amp	Peak-to-peak
Offset	Offset value
Frequency	Frequency value, the default maximum is 250Hz.
End State	Indicates the end state. Last (the voltage or current maintained at the last step after the end) or Normal (returns to the normal mode before Sine is executed).

- **Sweep: Sweep wave**

The fields included in the .csv template file are explained as follows:

Model	Device model, keep the default settings without modification.
Firmware Version	Firmware version number, keep the default settings without modification.
Serial Number	Device serial number, keep the default settings

	without modification.
File Type	File type, keep the default settings without modification.
Waveform Type	Waveform type, keep the default settings without modification.
Amp Unit	Peak-to-peak unit, CV priority is set to V, CC priority is set to A.
Offset Unit	Offset value unit, CV priority is set to V, CC priority is set to A.
Time Unit	Time unit, S.
Frequency Unit	Frequency unit, Hz.
Mode	Indicates the power supply working mode. The CV priority is set to CV, and the CC priority is set to CC.
Repeat	Repeat times, the setting range is 1~65535.
Amp	Peak-to-peak
Offset	Offset value
Start Frequency	Start frequency
End Frequency	Stop frequency
Step DwellH	Total running time.
Step time	Single-step pulse width. Single-step pulse width and single-step repetition times can be set by selecting one of them.
Step Repeat	The number of repetitions of a single step. Singlestep pulse width and single-step repetition times can be set by selecting one of them.
Step mode	Operation mode, can be set to 0 or 1. When set to 0, it means that the total running time Step DwellH and the single-step pulse width Step time are used as the running end condition; when set to 1, it means that the single-step repetition times Step Repeat is used as the running end condition.
End State	Indicates the end state. Last (the voltage or current maintained at the last step after the end) or Normal (return to the normal mode before the Sweep is executed).

The steps are as follows:

1. Edit the 8.csv file corresponding to the template on the PC and save it.
2. Save the edited file in the U disk.
  - The ARB files for dual-channel output mode and parallel output mode need to be placed in the arbParallel folder of the USB flash drive.
  - The ARB file for serial output mode needs to be placed in the arbSeries folder on the USB flash drive.

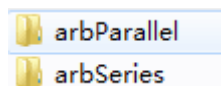

3. Insert the U disk into the front panel of the instrument. (The USB type needs to be set as Host.)
4. Click ARB on the Menu screen to enter the ARB function main interface.
5. Click the **[Open]** key on the screen, enter to ARB recall interface.
6. Click usb, select the 8.csv file in the usb, and click **[Open]** to confirm. The ARB file will be imported.

7. Press **[On/Off]** on the front panel, turn on the output.
8. Press **[Run]** key in the ARB function interface.
9. Based on the selected trigger method, perform the trigger operation.  
Take the manual trigger as an example. Press **[Shift]+[5]**(Trigger) on the front panel to run the selected ARB file.

## Programming via SCPI instructions

For detailed instructions and parameter introduction, please refer to the instructions of "ARB Subsystem" in the Programming Guide.

## Realized by the software PV6600 on PC

For detailed function usage, please refer to PV6600 User Manual.

## 4.4 Battery Charging Test Function

This series power supply provides the battery charging test function. Suitable for charging tests on all types of portable batteries.

### WARNING

- When connecting the DUT (battery/capacitor), do not short-circuit the battery/capacitor.
- Before performing the battery test, you need to connect the Sense cables to both ends of the battery. If the Sense cables are not connected, the instrument cannot detect the Sense voltage and prompt "Wait Sense Link!", which will prevent the battery test from continuing.

## Battery Charging Function

1. Click BAT on the Menu screen to enter the battery charging/discharging function interface.

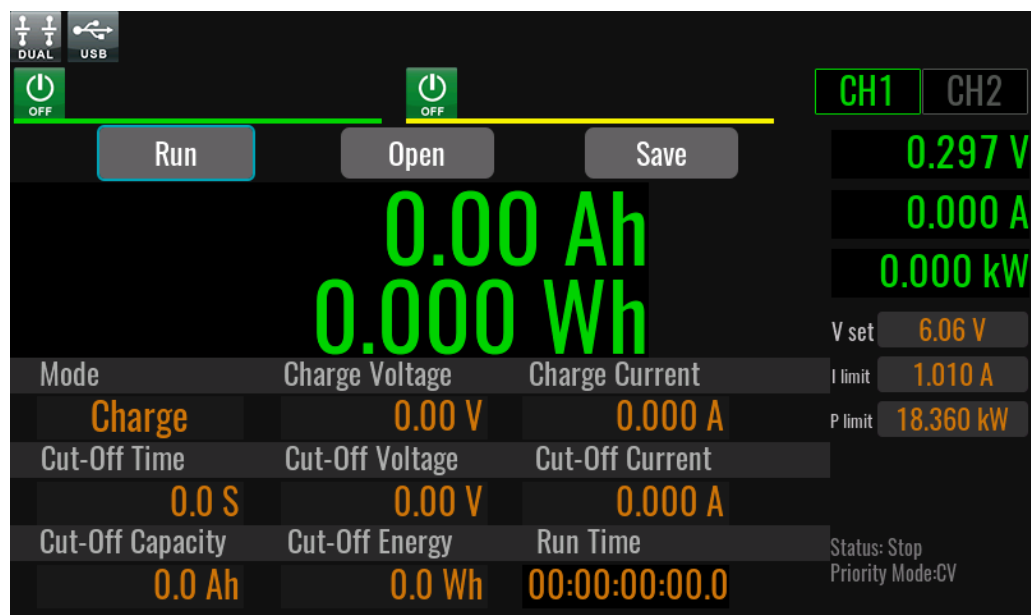

Parameter	Description
Mode	Select mode: Charge (battery charge mode).
Charge Voltage	Set the voltage value for charging.
Charge Current	Set the current value for charging.
Charge Time	Set the time value for charging.
Cut-Off Voltage	Battery test cut-off voltage.
Cut-Off Current	Battery test cut-off current.
Cut-Off Capacity	Battery test cut-off capacity.
Cut-Off Energy	Battery test cut-off energy.
Run Time	Display the running time of the battery test.
Run/Stop	Run/stop the Battery function.
Open	Select the Battery file to execute.
Save	Save the Battery file.

2. Set the charging parameters for the battery and press the **[Save]** button to save.
3. Press **[On/Off]** on the front panel, turn on the output.
4. Press **[Run]** in the Battery function interface.
5. Press **[Shift]+[5]**(Trigger) on the front panel to run the battery charging test.
6. Click **[Stop]** to stop the present running.

# Chapter5 System-Related Functions

## 5.1 System Menu Reference

Press **[Shift] + [P-set]** (System) to enter the menu function. At this time, LCD displays optional menus. Select and edit the menu items by pressing the Up, Down, Left and Right keys. Specific menu items are shown below. The menu items are shown below.

### Source menu

Source	Output Mode	Set the output mode.		
		Mode	<ul style="list-style-type: none"> <li>● <b>Series:</b> Configure the instrument to 2-channel series mode.</li> <li>● <b>Parallel:</b> Configure the instrument to 2-channel parallel mode.</li> <li>● <b>Dual:</b> Configure the instrument to 2-channel independent output mode. When the output mode of the instrument is configured Dual, the synchronization parameters of both channels can be further configured.</li> </ul>	
		Sync	<ul style="list-style-type: none"> <li>● On: Turns on the 2-channel synchronization mode.</li> <li>● Off: Turns off synchronization mode.</li> </ul>	
		Sync Mode	Synchronization mode.	
			<b>Track:</b> Set 2-channel to output on/off synchronization and voltage proportional changing. <ul style="list-style-type: none"> <li>● Reference: Set the voltage proportional relationship among 2-channel.</li> </ul>	
			<b>Onoff Only:</b> Set 2-channel to output on/off synchronization. <ul style="list-style-type: none"> <li>● Duplicate: Set the parameters of 2-channel to be fully synchronized.</li> </ul>	
		Remote sense	Set the sense function state.	
			Status	<ul style="list-style-type: none"> <li>● On: Enable the remote sense Measurement.</li> <li>● Off: Disable the sense function.</li> </ul>
		Output Rzero	Used to control whether the voltage is quickly zeroed after the output is turned off.	
			Status	<ul style="list-style-type: none"> <li>● On: Yes</li> <li>● Off: No</li> </ul>
		External Program	External analog function.(External analog interface is optional.) For detailed introduction of menus and functions, see <a href="#">5.10 Analogue Function</a> .	
		Measure	Set the measurement speed.	
			Low	Low mode, measuring every 200ms.
			Medium	Medium mode, measuring every 100ms.
			Fast	Fast mode, measuring every 20ms.
	Power Unit Setting	Set the power unit: W or kW.		
	Redundant Setting	Set the redundant status: On or Off.		

**General menu**

General	Buzzer	Set the buzzer sound.	
		Key Sound	Buzzer on/off for key.
		Warning Sound	Buzzer on/off for warn.
		Protection Sound	Buzzer on/off for protect.
	Brightness	Set the screen brightness.	
		1-10	Set the screen brightness level.
	Factory Default Settings	Select whether to reset the factory default settings or not.	
		Restore	Confirm to reset operation
	Power-on Setup	Set the power-on state.	
		Reset	When the instrument is powered on, the instrument will initialize some settings and [On/Off] state.
		Last	When the instrument is powered on, the instrument will remain the same settings and [On/Off] state as last time you turned off the instrument.
		Last-off	When the instrument is powered on, the instrument will remain the same settings as last time you turned off the instrument, but the [On/Off] is Off state.
	Parallel Settings	Set the instruments to parallel operation mode.	
		Role	<ul style="list-style-type: none"> <li>● Single: Set the instrument to single mode, i.e., disable the parallel operation mode.</li> <li>● Master: Set the instrument to master mode.</li> <li>● Slave: Set the instrument to slave mode.</li> </ul>
		Number	Number of parallel instruments.
	Touch Function	Lock the touch screen function.	
		Status	Set the On/Off state.
	Knob Immediately Effective	Knob setting will take effect immediately. When set to On, the output value will immediately take effect upon rotating the knob. When set to Off, after adjusting the knob, the output value will only take effect after pressing the Enter key to confirm.	
	Language	Set the language of display.	
		English	English
		Chinese	Chinese
	Soft Keyboard	Set the soft keyboard	
		On	Turn on the soft keyboard. The soft keyboard will pop up when the edit box is in editing mode.
		Off	Turn off the soft keyboard.
	Hover Button		
		On	Use the hover button for full touch mode operation.
		Off	Turn off the hover button.
Communication	USB type	Set the USB type.	
		Device: the USB device is used to communication with PC.	
		Host: the USB device is used to storage disk.	

	USB device class	USB communication interface	
		VCP	Virtual serial port
		TMC usbtmc	USB-TMC protocol
	LAN Settings	LAN communication interface	
		Mode	<ul style="list-style-type: none"> <li>● DHCP: automatically configure the address of the instrument.</li> <li>● Manual: manually configure the address of the instrument by entering values in the following five fields.</li> </ul>
		IP	Set the IP address.
		Mask	Set the subnet mask.
		Gateway	Set the gateway address.
		Port	Set the port number.
	RS232 Settings	Select RS232 communication interface. When insert IT-E177 communication board into expansion slot, the menu displays this information.	
		Baud rate	Baud rate
		Data bits	Data bit: 5/6/7/8
		Stop bits	Stop bit: 1/2
		Even-odd check	Parity bit: N (No parity) / E (Even parity) / O (Odd parity)
		Address	Address
	GPIB Settings	Select GPIB communication interface. When insert IT-E176 communication board into expansion slot, the menu displays this information.	
		Address	Set the communication address
	CAN Settings	CAN communication interface.	
		Baud rate	Select the baud rate
		Address	Set the instrument address to a number
		Protocol	<ul style="list-style-type: none"> <li>● CAN_OPEN: High-level protocol for the CAN bus.</li> <li>● CAN2.0: ITECH CAN version 2.0 protocol.</li> </ul>

## IO menu

IO	Digital IO-1 Settings	Set Digital I/O. For detailed introduction of menus and functions, see <a href="#">5.9 Digital I/O Function</a> .
	Digital IO-2 Settings	
	Digital IO-3 Settings	
	Digital IO-4 Settings	
	Digital IO-5 Settings	
	Digital IO-6 Settings	
	Digital IO-7 Settings	
Information	Product model	Display the instrument model.
	SN	Display the serial number.
	Software version	Display the system version information.
	MAC address	MAC address
	Rbf version	Rbf version
	Ctrl1 version	Ctrl1 version
	Ctrl2 version	Ctrl2 version
	Inner numbers	Number of Inner Ring Parallel Machines.
Power On Time	The power on time of the machine.	

	Current Output Time	The current output time of the machine.
	History Output Time	The history output time of the machine.

## Set the buzzer sound

- **Key Sound:** This item can set the key sound state. If in ON mode, then when you press a button, the power supply will beep. If in OFF mode, the beeper will not make a sound. The default set is in ON mode.
- **Protection Sound:** This item allows you to set the protection sound status. If it is in ON mode, the power supply will beep when protection occurs. If it is in OFF mode, the buzzer will not sound. The default setting is ON mode.
- **Warning Sound:** This item allows you to set the warn sound status. If it is in ON mode, the power supply will beep when a warning occurs. If it is in OFF mode, the buzzer will not sound. The default setting is ON mode.

## Set the screen brightness

This item can set the screen brightness. Set the screen brightness within the range 1 to 10 by pressing number keys on the front panel. The larger the number is, the higher the screen brightness is. You can also set the screen brightness by rotating the knob on the front panel. Default setting is 5.

## Restored to Factory Setting

This menu item is used to restore all settings of the instrument to factory default values.

The procedures to set the menu item are as follows.

1. Select the **General** under system menu.
2. Press **Restore** in Factory Default Settings.

## Set the Power-on State

This parameter determines the state of the DC source after power up.

The procedures to set the menu item are as follows.

1. Press the **General** under the system menu.
2. Press the Up/Down key or turn the knob to select the **Power-on setup** and press **[Enter]**.
  - **Reset:** Default value, indicates when the instrument is powered on, the instrument will initialize some parameter settings or state, such as output voltage, output current and output status.
  - **Last:** Indicates when powered on, the instrument will remain the same parameter settings and output status as last time you powered off the instrument.
  - **Last+Off:** Indicates when powered on, the instrument will remain the same settings as last time you powered off the instrument, but the output status is **Off**.

## Set the Knob Function

Set the knob setting function. If set to ON, the Knob setting will take effect immediately. If set to OFF, press Enter to confirm the effect after the Knob setting is completed.

## Select Language

Users can select the instrument language type from the menu.

## Set the Soft Keyboard

The user can open the soft keyboard in the menu. When the parameter is set to ON, the soft keyboard is enabled. And when setting parameters on the screen, the soft keyboard appears. Convenient users directly touch screen to select the number.

## 5.2 Configuration Menu Reference

Press **[Shift] + [V-set]** (Config) key and enter to configuration menu interface. At this interface, user can setup the power supply output parameters, detailed parameters are shown as follows.

Config	Configuration menu of the power supply.		
	Priority Mode	CC/CV priority mode setting.	
		Mode	Mode Settings.
			CV: Constant voltage loop priority mode.
			CC: Constant current loop priority mode.
		Loop Speed	Loop response speed setting.
			High: high speed.
			Medium: medium speed.
			Low: low speed.
	Slew Config	Slew Setting.	
		Mode	Select the slew unit.
			Time: describe the slew of the device in terms of time.
			Standard: standard slew, unit is V/ms or A/ms.
		V-Rise/ I-Rise	Displays the voltage or current rise slew setting according to the selected priority mode. If CC priority mode is selected, the parameter setting of I-Rise will be displayed here.
		V-Fall/ I-Fall	Displays the voltage or current fall slew setting according to the selected priority mode. If CC priority mode is selected, the parameter setting of I-Fall will be displayed here.
	Output Couple Mode	Set the output mode.	
	Mode		
		DC: DC mode.	
Output Resistance	Set the internal resistance of the power supply. (This item is only displayed when <b>CV</b> is prioritized.)		
Onoff Delay			
	On Delay	Set the delay time to turn on the output.	
		<b>Offset:</b> Set the output delay offset time.	
	Off Delay	Set the delay time to turn off the output.	

## 5.3 Key Lock Function

Press **[Shift] + [2]** (Lock) button to set the key lock state. If keyboard has been

locked, the indicator light  will display on the LCD. In addition, when keyboard are locked, all buttons can't be used except Local key Press **[Shift] + [2]** (Lock) once again will relieve key lock function.

## 5.4 Switching Local/Remote Mode

You can press the **[Shift] + [3]** (Local) button to change the DC source from remote to local operation.

After you power on the DC source, it defaults in local mode, all buttons are enabled. While in remote mode, most buttons are disabled except **[Shift] + [3]** (Local) keys. You can switch Local/Remote mode via PC. In addition, the mode modification will not affect the output parameters.

## 5.5 Save and Recall Operations

The power system can save up to 100 common parameters in nonvolatile memory (No. 1 to No. 100) for user to recall conveniently.

The saved parameters include:

- Power supply mode
- Present output parameters
- Config menu settings

### Save Operation

The save operation procedures are as follows:

1. Press the composite keys **[Shift]+[4]**(Save) to enter the parameter save interface.
2. Select the storage location. up to 100 position can be select.



3. Press **[Enter]** to save the parameters.

Finished, the saved parameters will be display at the right side of the interface.

### Recall Operation

You can recall the parameters you saved in the specified memory location as

the setting values.

1. Press the **[Recall]** key to enter the parameter recall interface.
2. Set the storage location.

Press the direction keys to set the storage location, and then, the saved parameters will be display at the bottom of the interface.

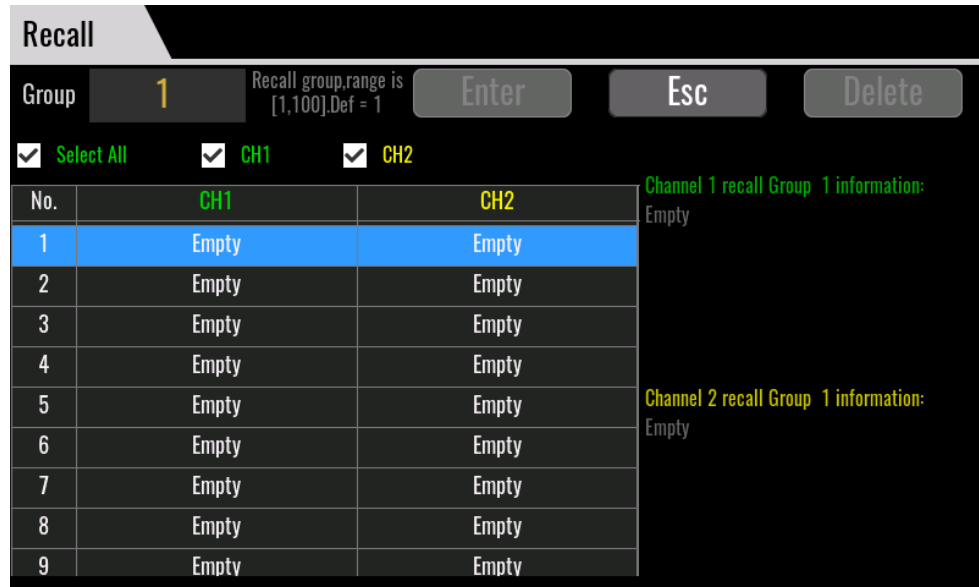

3. Press **[Enter]** to recall the parameters.

## 5.6 Screen Capture Function

IT6600 series power supply has the screen capture function. Insert the USB equipment into the USB interface of the front panel, and press **[Print]** on the front panel to capture and save the current screen into the USB disk.

When you need the screen capture function, the USB type under the system menu needs to be set to **Host**.

## 5.7 Query the System Log

The IT6600 series power supply provides the system operation Log query function. On the Menu interface of the front panel of the instrument, click Log or directly press **[Shift]+[1]**(Log) to enter the Log query interface. You can view historical system operation records on this screen.

## 5.8 Multi-units operation

### 5.8.1 Series Operation(single-unit)

The IT6600 power supply can increase its output voltage and power by connecting the two channels of a single instrument in series. When connected in series, the upper limit of the voltage setting range is twice the rated value of a single channel, and the instrument is used as a single channel power supply at this time.

#### Operation steps

1. Set the two channels of the power supply to **Series** mode.
  - a) Press the composite keys **[Shift] + [P-set]** (System) on the front panel

to enter the system menu.

- b) Select the **Source** tab, then press the up/down key or rotate the knob to find **Output Mode** menu.
- c) Press the up/down key to move the cursor to the **Mode** function setting and press the **[Enter]** key to confirm. Rotate the knob to set **Series** output mode, and press the **[Enter]** key to confirm.

2. Refer to the figure below to connect the DUT, and live wiring is prohibited.

- Local sense

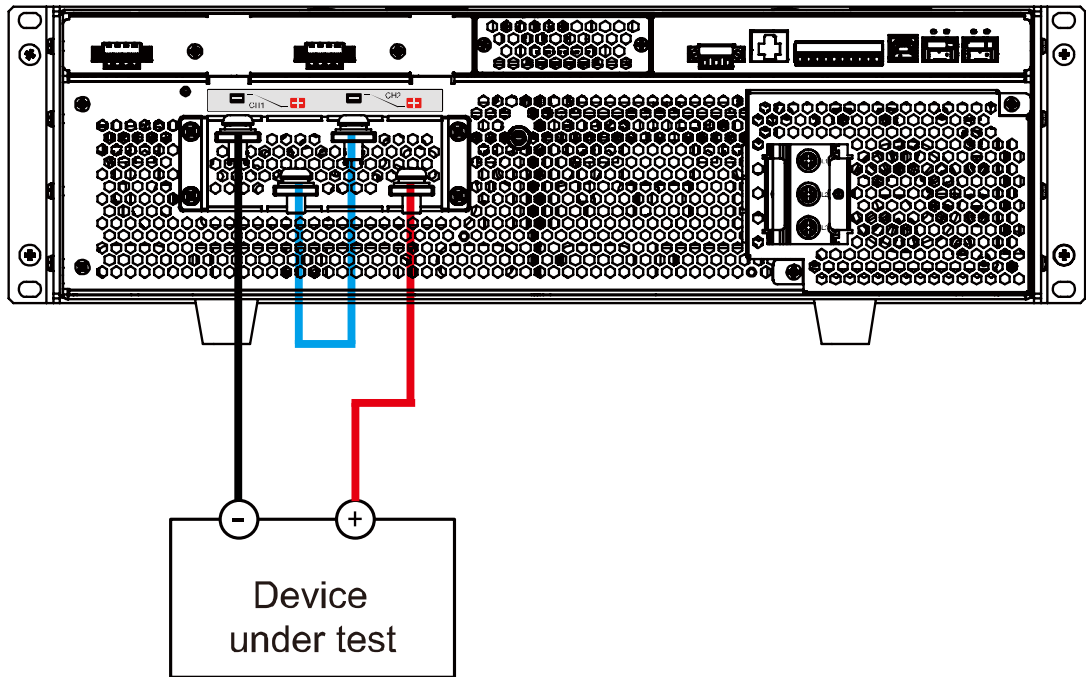

- Remote sense

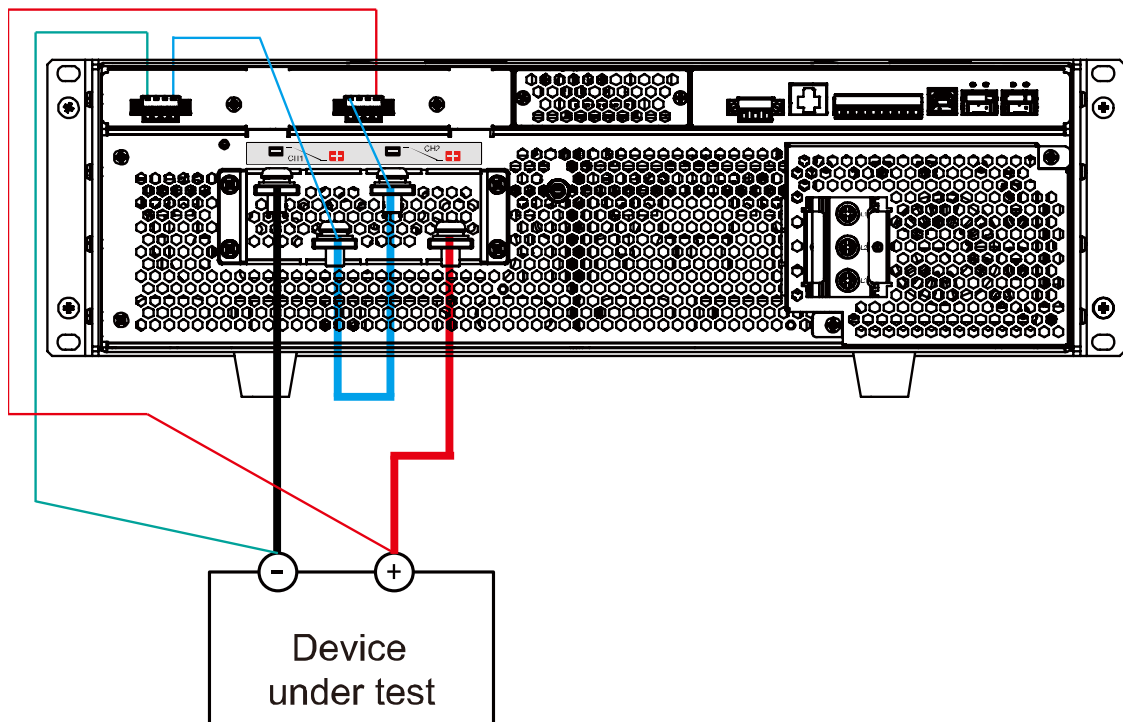

## 5.8.2 Parallel Operation(single-unit)

The IT6600 power supply can increase its output current and power by connecting the two channels of a single instrument in parallel. When connected in parallel, the upper limit of the current setting range is twice the rated value of a single channel, and the instrument is used as a single channel power supply at this time.

### Operation steps

1. Set the two channels of the power supply to **parallel** mode.
  - a) Press the composite keys **[Shift] + [P-set]** (System) on the front panel to enter the system menu.
  - b) Select the **Source** tab, then press the up/down key or rotate the knob to find **Output Mode** menu.
  - c) Press the up/down key to move the cursor to the **Mode** function setting and press the **[Enter]** key to confirm. Rotate the knob to set **Parallel** output mode, and press the **[Enter]** key to confirm.
2. Refer to the figure below to connect the DUT, and live wiring is prohibited.

- Local sense

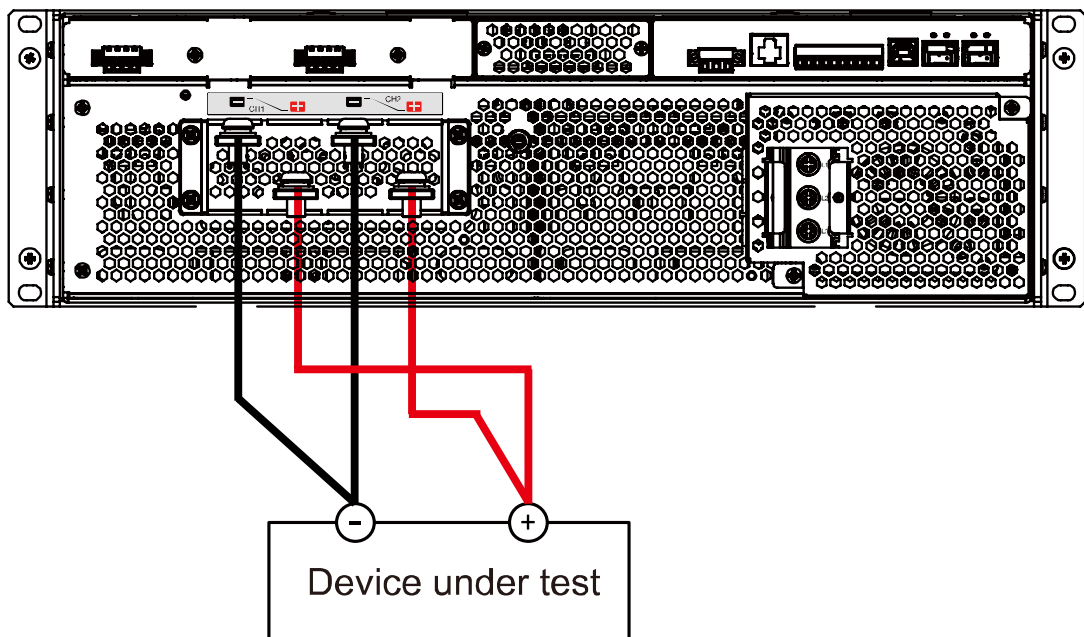

- Remote sense

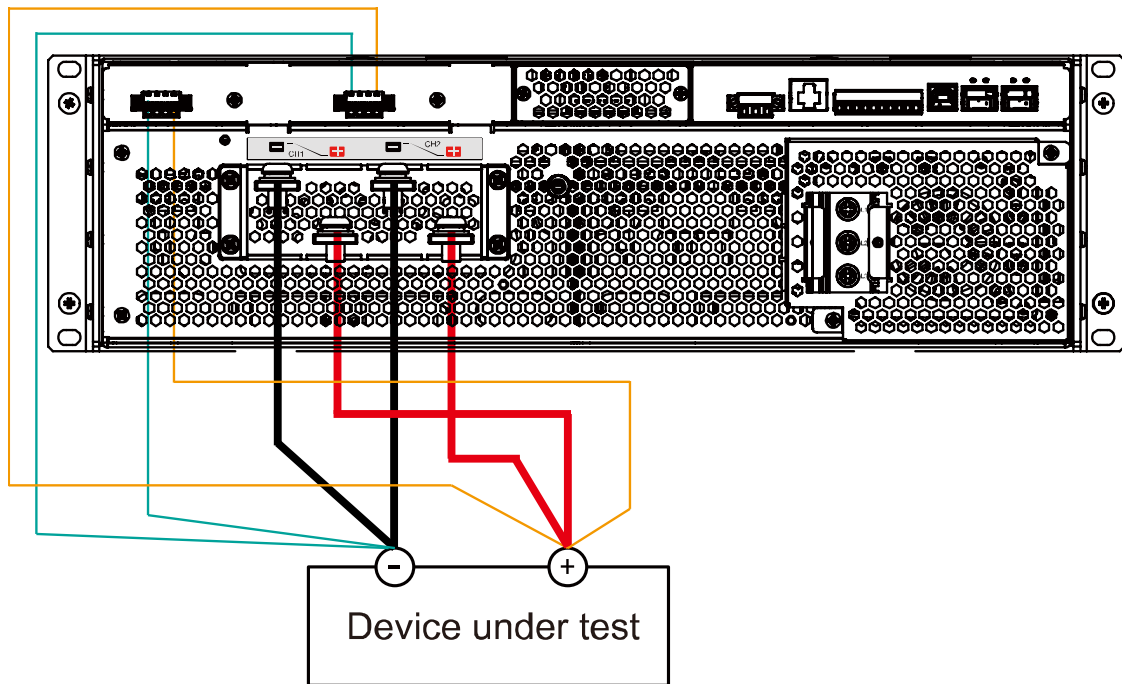

### 5.8.3 Parallel Operation(multi-units)

The IT6600 series power supply supports multiple instruments to work in parallel mode to provide more power and current output capability. Under the parallel mode, all features are set up from the master unit.

This chapter takes three instruments (with operation panel) as an example to describe how to parallelize the single units and how to return from parallel mode to single mode.

#### Set the Parallel Mode

##### WARNING

- Before connecting the cables, ensure that the instrument power switch is off and the main switch of the AC power input (distribution box) is off.
- Before connecting 3 single instruments to the AC distribution box, ensure that the distribution box capacity is sufficient. Refer to the corresponding specifications for the AC input parameters of a single instrument.
- Before connecting the system bus, you must ensure that each instrument is in single mode (Single).
- Fiber optic cables cannot be flexed or folded. When the cable is too long and needs to be arranged, gently wrap the cable in a circle and gently tie it.

1. Ensure that the power switches of the three units and the main switch of the AC power distribution box are off.
2. Connect the instruments according to the following diagram.
  - In dual-channel mode, the wiring schematic is shown below.

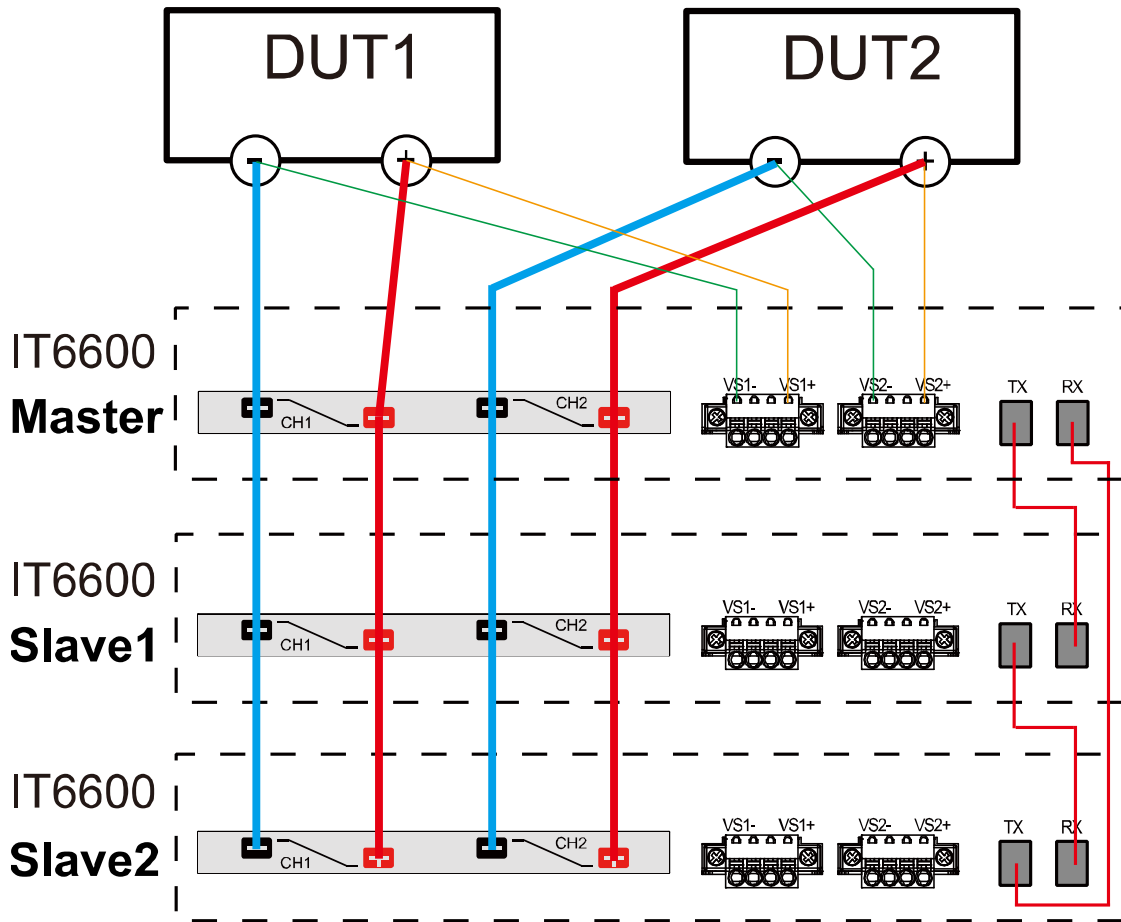

- In series mode, the wiring schematic is shown below.



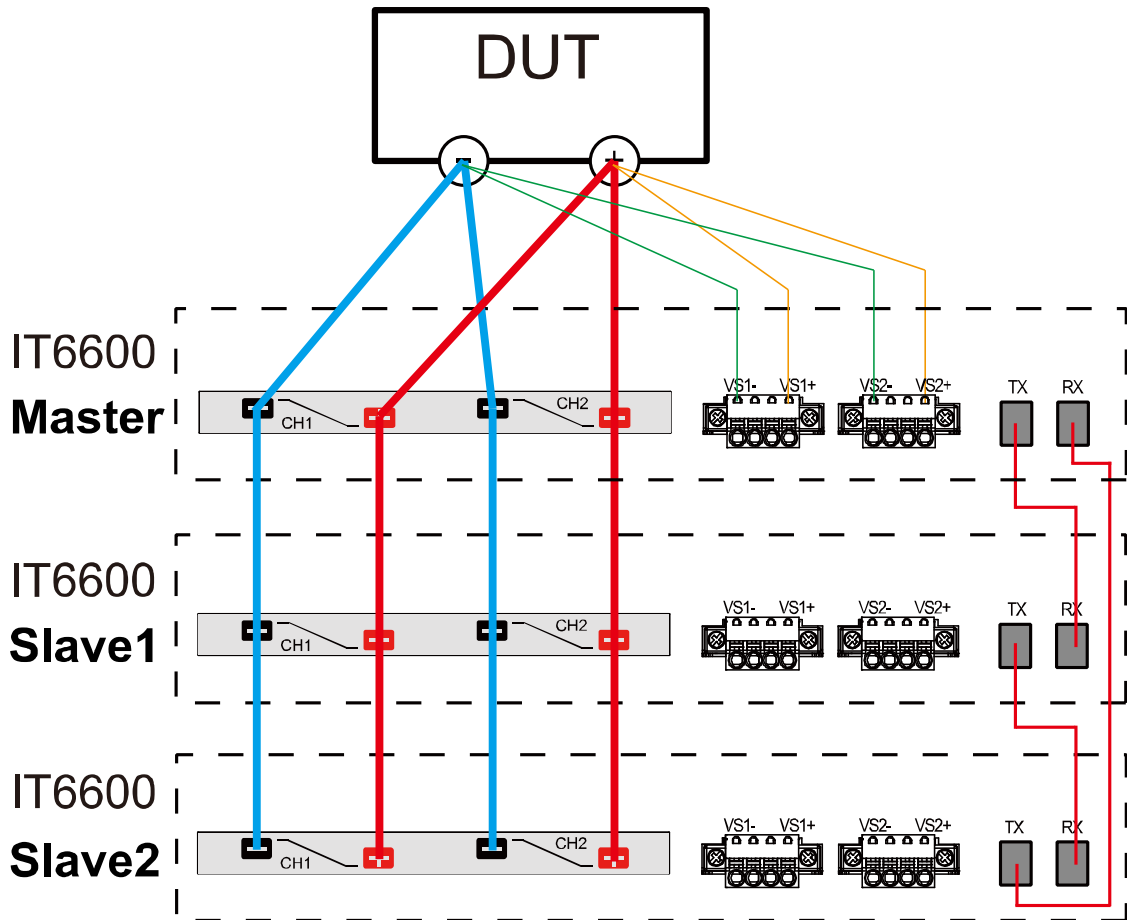

- a) Connect the DC output terminals of the three instruments in parallel and connect them to the device under test according to different output modes.
- b) Refer to the blue wiring legend in the figure, connect the System Bus (i.e., the fiber outer ring interfaces TX and RX) for fiber-optic communication between the master and slaves.

Insert the fiber optic module into the hole corresponding to TX RX.

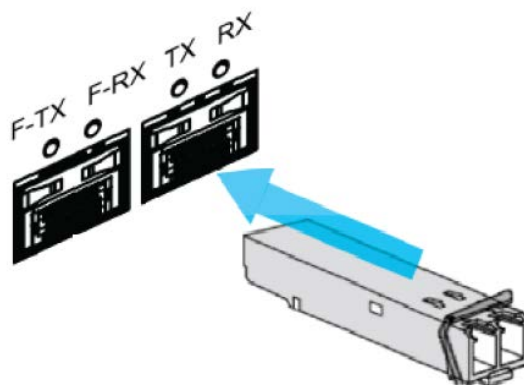

Insert the plug of the fiber optic cable into the fiber optic module and hear a click sound to indicate that it is inserted in place. The fiber optic cable connection schematic is as follows.

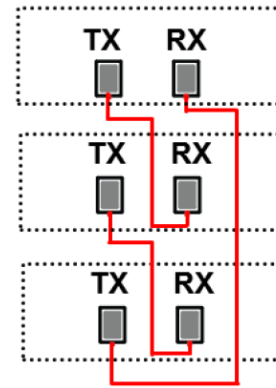
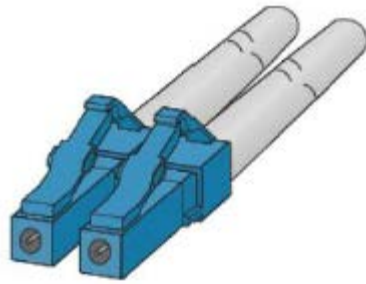

3. After connection, configure one power supply as a master unit and other power supplies as slave units.
  - a) Press the composite keys **[Shift] + [P-set]** (System) on the front panel to enter the system menu.
  - b) Press the up/down key or rotate the knob to find **General->Parallel Settings** menu.
  - c) Set the **Role**, set them to one master unit and two slave units. In each group, one instrument must be the master unit and all other instruments connected in parallel are slave units. All features are set up from the master unit.
    - Single: Default value, indicates that the instrument is in single mode.
    - Master: Indicates that the single unit is set to master in parallel mode.

Numbers: total number of units in the parallel relationship, when the instrument set to master, you need to set the Numbers. For example, Numbers set to 3.

    - Slave: Indicates that the instrument is set to the slave in parallel mode.
  - d) Press **[Esc]** to exit.
4. After making the master-slave setting, to ensure normal operation, you need to restart the power supplies.

## Revert to single mode

To change Parallel Mode to Single Mode, follow the steps below:

1. Switch three instruments into single mode respectively.
  - a) Press the composite keys **[Shift] + [P-set]** (System) on the front panel to enter the system menu.
  - b) Press the up/down key or rotate the knob to find **General->Parallel Settings** menu.
  - c) Set the **Role**, set them to single.
2. Power off the three instruments and turn off the main switch of the AC distribution box.
3. Remove the cables connection of the System Bus and output terminals between three units.
4. Power on the three instruments separately. After the instrument is restarted,

the screen shows that the instrument is working in single mode.

### 5.8.4 Parallel Operation(one master and multi-slaves)

“One master and multiple slaves” means that there is only one instrument with operating panel (namely, the master) in the parallel system, and the other instruments have no operating panels (namely, the slaves). In the “one master and multiple slaves” system, you only need to operate the master’s front panel.

This section uses three instruments as an example to introduce the steps for parallel connection with one master and two slaves. The type and assembly method for parallel connection of other quantities of instruments are the same.

#### WARNING

- Before connecting the cables, ensure that the instrument power switch is off and the main switch of the AC power input (distribution box) is off.
- Before connecting 3 single instruments to the AC distribution box, ensure that the distribution box capacity is sufficient. Refer to the corresponding specifications for the AC input parameters of a single instrument.
- Fiber optic cables cannot be flexed or folded. When the cable is too long and needs to be arranged, gently wrap the cable in a circle and gently tie it.

1. Ensure that the power switches of the master unit and the main switch of the AC power distribution box are off.
2. Connect the instruments according to the following diagram.
  - In dual-channel mode, the wiring schematic is shown below.

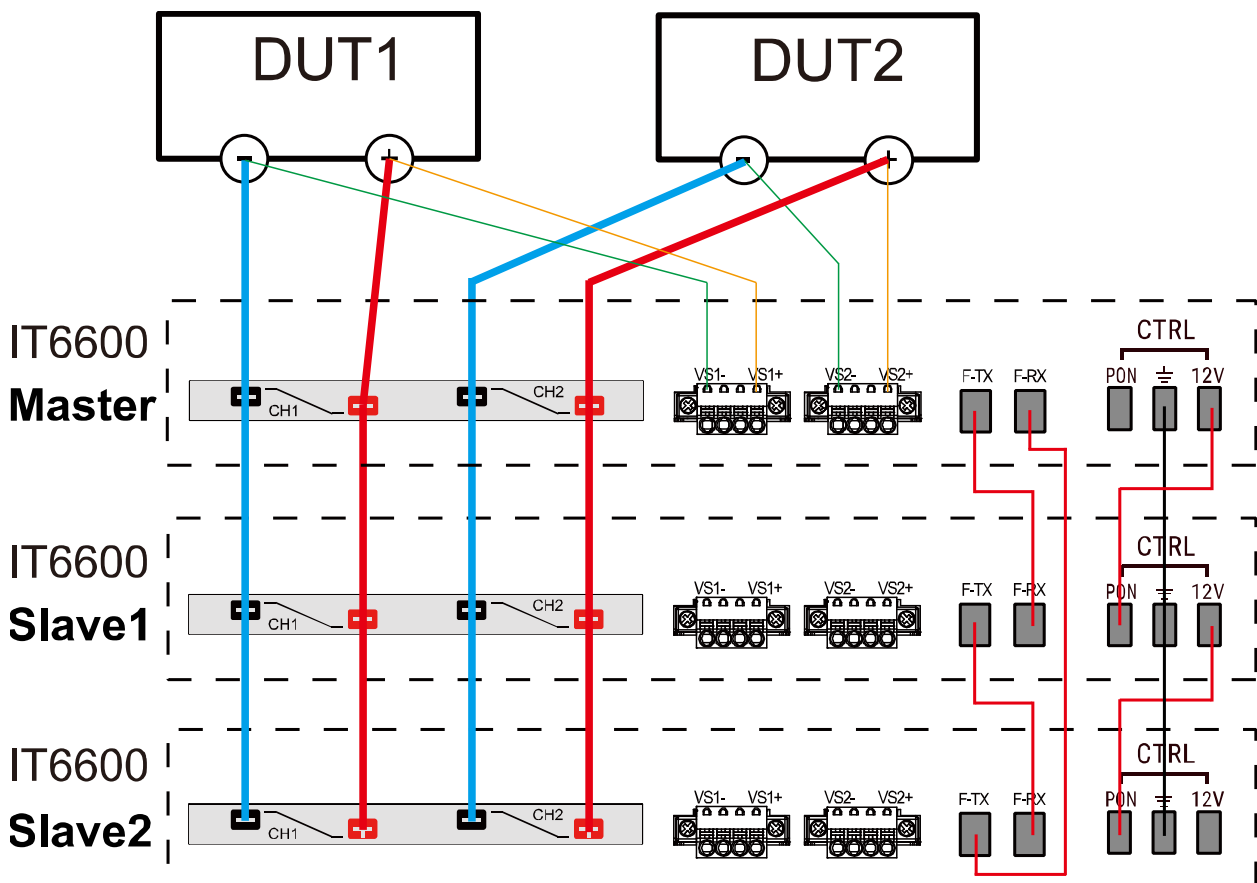

- In series mode, the wiring schematic is shown below.

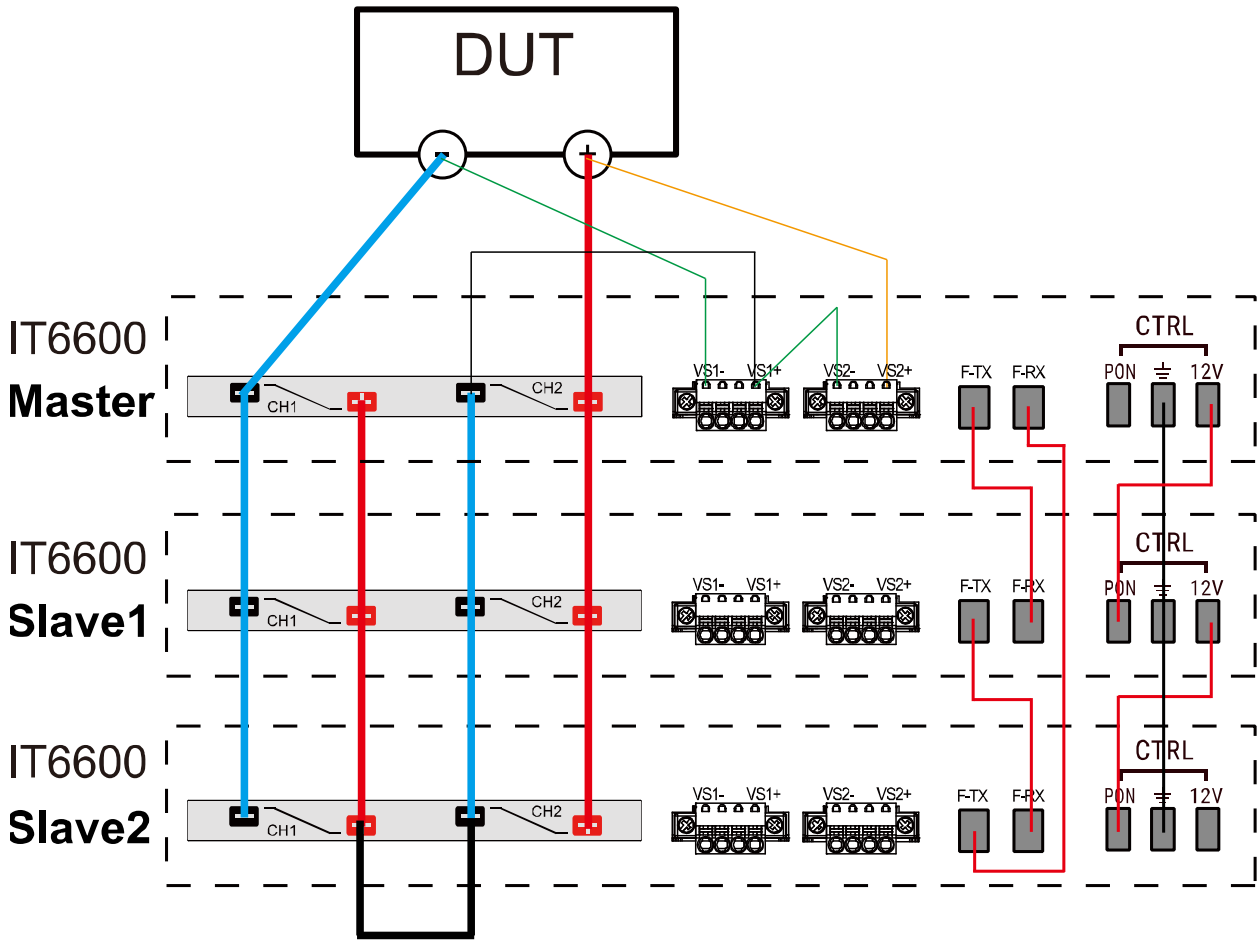

- In parallel mode, the wiring schematic is shown below.

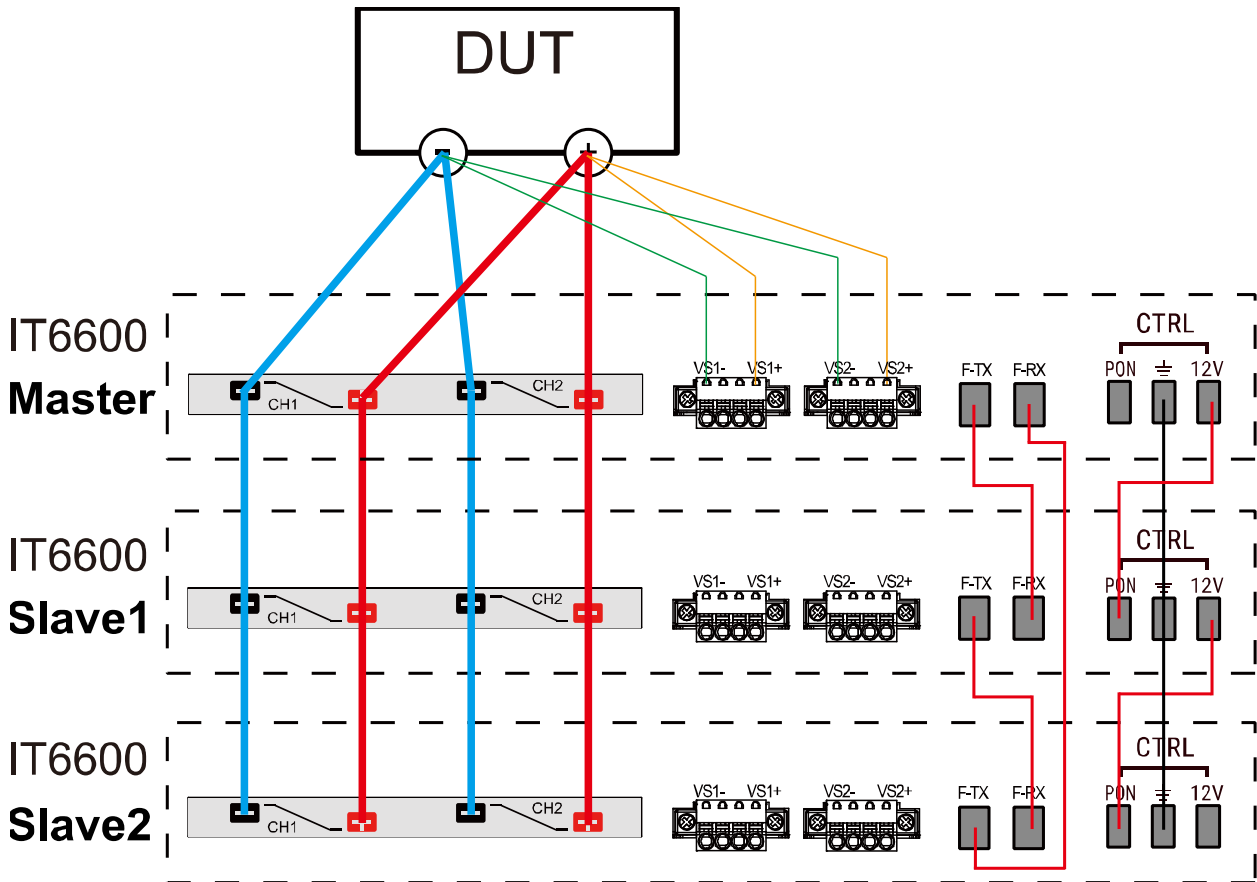

a) Connect the DC output terminals of the three instruments in parallel and connect them to the device under test according to different output modes.

b) Connect the CTRL cables.

Wiring rules are as follows: Connect the GND/12V of the first single unit to the second single unit's GND/PON, and the second single unit's GND/12V to the third single unit's GND/PON, and so on, until the last single unit is connected.

c) Refer to the wiring legend in the figure, connect the System Bus (i.e., the fiber inner ring interfaces F-TX and F-RX) for fiber-optic communication between the master and slaves.

Insert the fiber optic module into the hole corresponding to F-TX, F-RX. Insert the plug of the fiber optic cable into the fiber optic module and hear a click sound to indicate that it is inserted in place.

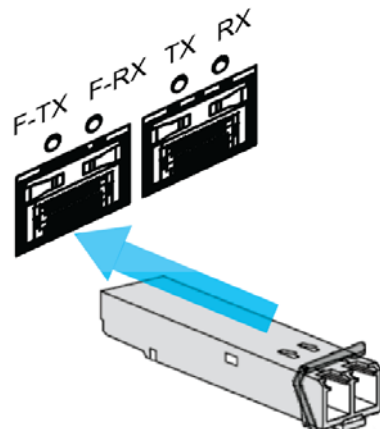

### 3. Configuring the Master and Slave

- a) Turn on the power switch on the front panel of the Master unit.
  - b) Press the composite keys **[Shift] + [P-set]** (System) on the front panel to enter the system menu.
  - c) Press the up/down key or rotate the knob to find **General->Parallel Settings** menu.  
Set the **Role**, set instrument with operating panel to single unit.
  - d) In the Info interface, press the combination key of **[Shift] + [.] + [3] + [8]**.  
Set the number of inner ring parallel instruments, such as Inner Number = 3, and press **[Enter]**.
  - e) Turn off the power switch on the front panel of the Master unit. After the power is turned off completely, turn on the power switch again.
4. After the instrument is restarted, the parallel operation is complete.

### 5.8.5 Parallel Operation(cabinet model)

For cabinet models, the same voltage level can be connected in parallel. Taking two 15U instruments (with operation panel) as an example, the steps for parallel operation are as follows.

#### WARNING

- **Before connecting the cables, ensure that the instrument power switch is off and the main switch of the AC power input (distribution box) is off.**
- **Before connecting 3 single instruments to the AC distribution box, ensure that the distribution box capacity is sufficient. Refer to the corresponding specifications for the AC input parameters of a single instrument.**
- **Before connecting the system bus, you must ensure that each instrument is in single mode (Single).**
- **Fiber optic cables cannot be flexed or folded. When the cable is too long and needs to be arranged, gently wrap the cable in a circle and gently tie it.**

1. Ensure that the power switches of the two cabinets and the main switch of the AC power distribution box are off.
2. Connect the cabinets according to the following diagram.
  - In dual-channel mode, the wiring schematic is shown below.

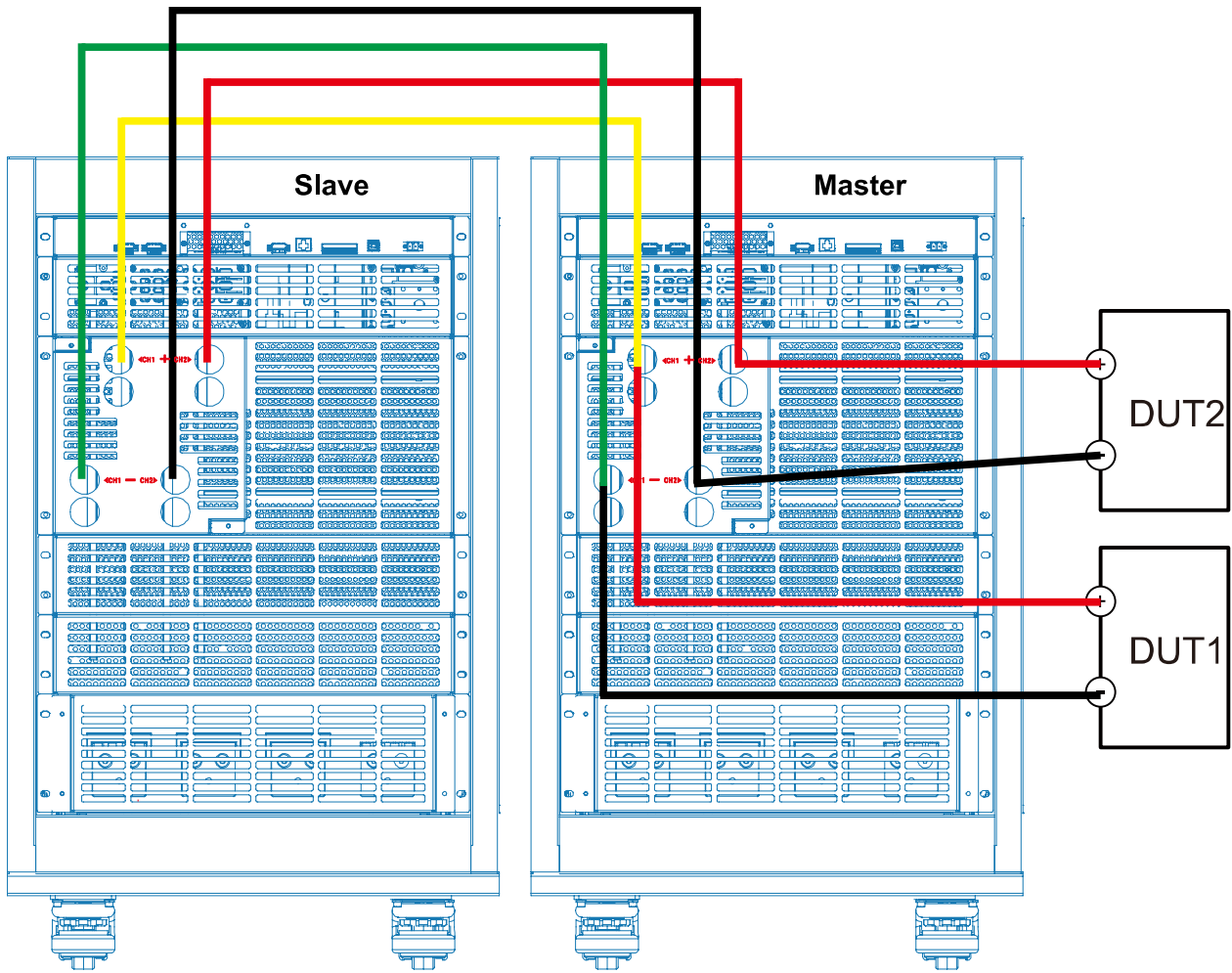

- In series mode, the wiring schematic is shown below.

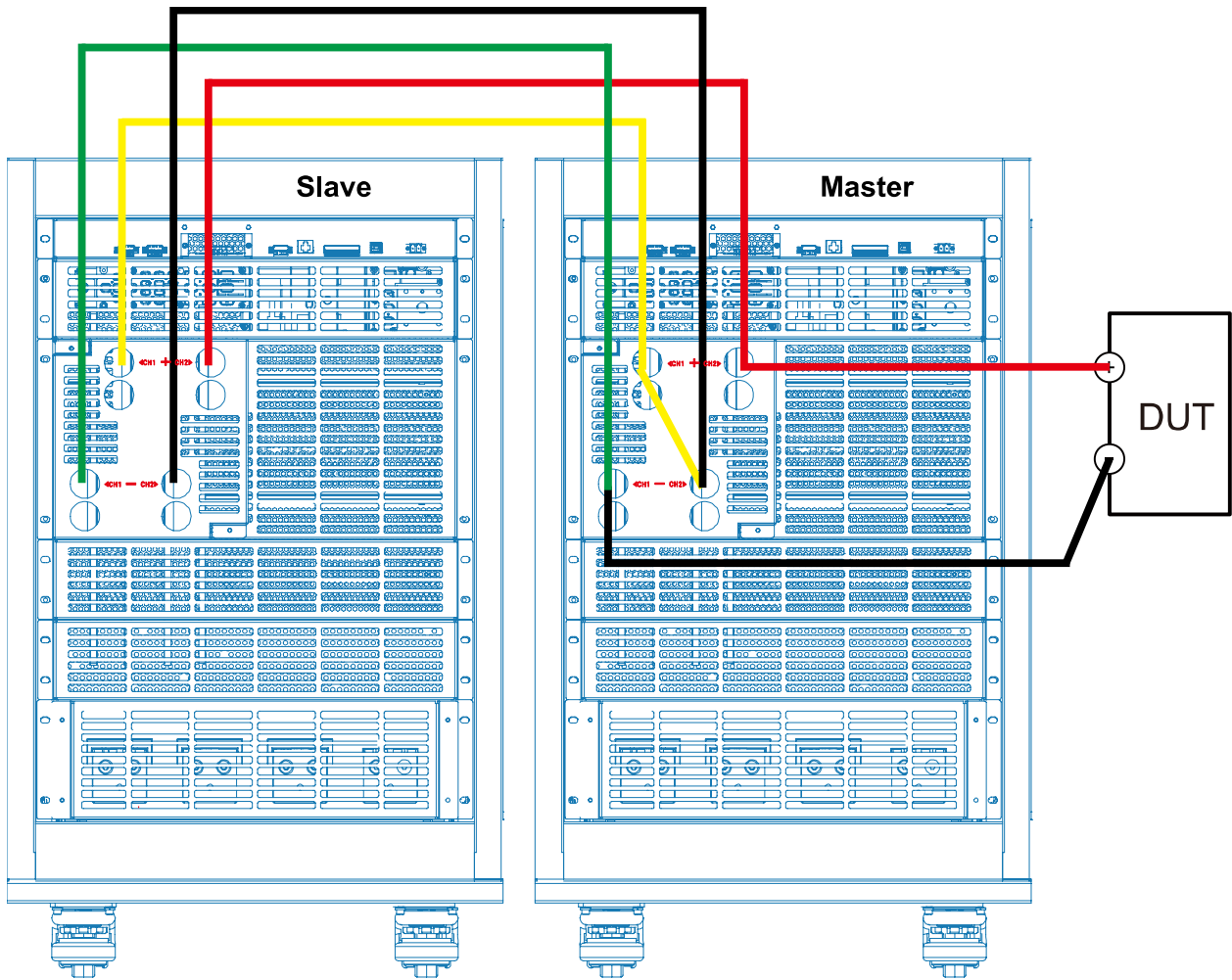

- In parallel mode, the wiring schematic is shown below.

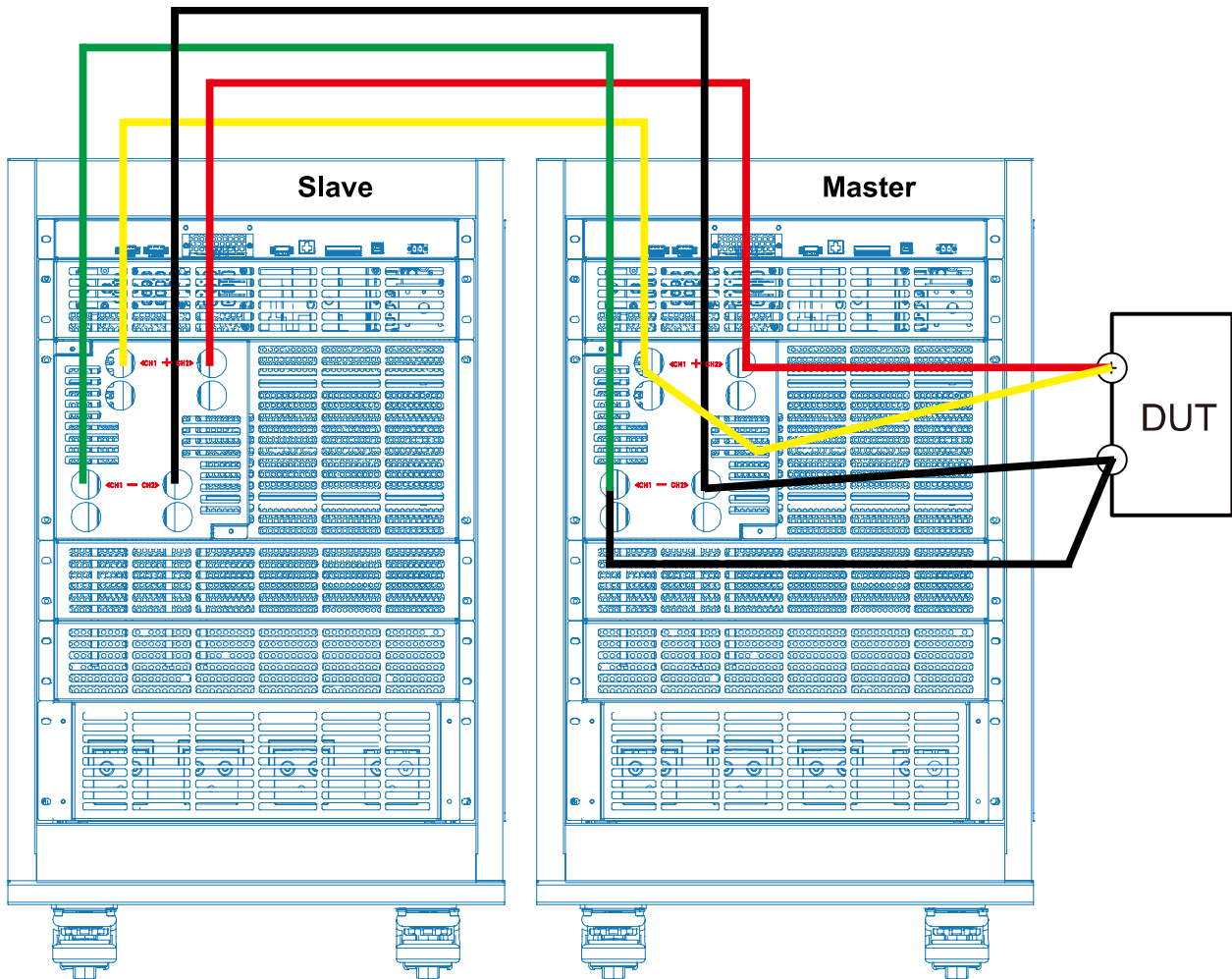

- a) Connect the DC output terminals of the two cabinets in parallel and connect them to the device under test according to different output modes.
- c) Refer to the figure below, connect the System Bus (i.e., the fiber outer ring interfaces TX and RX) for fiber-optic communication between the master and slaves.

Insert the fiber optic module into the hole corresponding to TX RX.

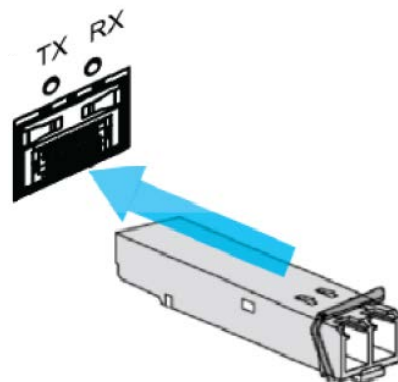

Insert the plug of the fiber optic cable into the fiber optic module and hear a click sound to indicate that it is inserted in place. The fiber optic cable connection schematic is as follows.

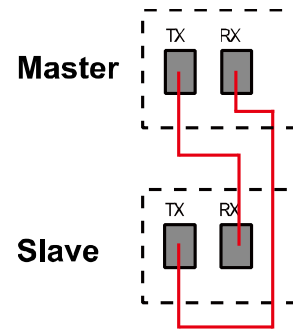
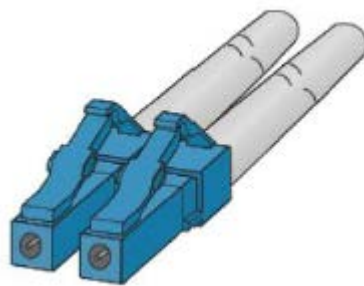

3. After connection, configure one cabinet as a master unit and other cabinets as slave units.
  - a) Press the composite keys **[Shift] + [P-set]** (System) on the front panel to enter the system menu.
  - b) Press the up/down key or rotate the knob to find **General->Parallel Settings** menu.
  - c) Set the **Role**, set them to one master unit and one slave unit. In each group, one cabinet must be the master unit and all other cabinets connected in parallel are slave units. All features are set up from the master unit.
    - Single: Default value, indicates that the cabinet is in single mode.
    - Master: Indicates that the single unit is set to master in parallel mode.  
Numbers: total number of units in the parallel relationship, when the cabinet set to master, you need to set the Numbers. For example, Numbers set to 2.
    - Slave: Indicates that the cabinet is set to the slave in parallel mode.
  - d) Press **[Esc]** to exit.
4. Turn off the power switch on the front panel of the cabinet in turn. After the power is turned off completely, turn on the power switch again.  
After the cabinets are restarted, the parallel operation is complete.

## 5.9 Digital I/O Function

This series power supply supports digital I/O function. The user can realize logic control over high and low level input or output by related configurations in the system menu. The appearance of the terminals are shown below.

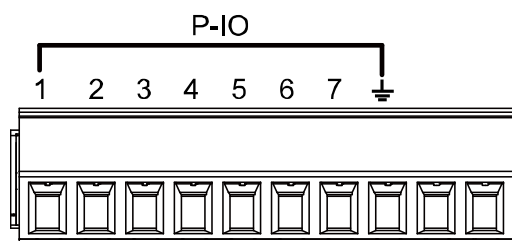

### 5.9.1 Description of Digital I/O pin

A Digital Control Port consisting of seven I/O pins is provided to access various control functions. Each pin is user-configurable.

Taking pin 3 as an example, IO-3 contains three function options, the first option **Off Status** is the default function, and this function is also a special custom function unique to this pin (the seven pins each have a different custom function). The second and third options (**Input** and **Output**) are the general digital I/O function, and the parameter settings and functions of the seven pins are the same.

## Description of Digital I/O pin parameter

Press **[Shift] + [P-set]** (System) to access the system menu functionality page, then select the IO tab to configure relevant parameters.

IO	Digital IO-1 Settings	Function setting of pin 1.	
		Reverse	On/Off, Select Invert or not under the IO Settings. If setting to ON, it means the valid signal is reversed.
		Function	<ul style="list-style-type: none"> <li>● PS Clear: This default function means that when the instrument generates protection, the protection state can be cleared via this pin.</li> <li>● Input: Pin 1 receives the level signal from the outside.</li> <li>● Output: Pin 1 sends the digital signal (1, 0) to the outside.</li> <li>● PWM: Pin 1 sends the PWM signal to the outside.</li> </ul>
	Digital IO-2 Settings	Function setting of pin 2.	
		Reverse	On/Off, Select Invert or not under the IO Settings. If setting to ON, it means the valid signal is reversed.
		Function	<ul style="list-style-type: none"> <li>● PS: This default function means the output level from pin 2, which displays that whether the instrument is under protection or not.</li> <li>● Input: Pin 2 receives the level signal from the outside.</li> <li>● Output: Pin 2 sends the digital signal (1, 0) to the outside.</li> <li>● PWM: Pin 2 sends the PWM signal to the outside.</li> </ul>
		Channel (Displayed only when Function is set to 'PS'.)	<ul style="list-style-type: none"> <li>● CH1: Apply the configuration to Ch1.</li> <li>● CH2: Apply the configuration to Ch2.</li> <li>● CH1&amp;CH2: Apply the configuration to Ch1 and Ch2.</li> </ul>
	Digital IO-3 Settings	Function setting of pin 3.	
		Reverse	On/Off, Select Invert or not under the IO Settings. If setting to ON, it means the valid signal is reversed.
		Function	<ul style="list-style-type: none"> <li>● Off Status: This default function indicates the existing <b>[On/Off]</b> state of the instrument.</li> <li>● Input: Pin 3 receives the level signal from the outside.</li> <li>● Output: Pin 3 sends the digital signal (1, 0) to the outside.</li> </ul>
		Channel (Displayed only when Function is	<ul style="list-style-type: none"> <li>● CH1: Apply the configuration to Ch1.</li> <li>● CH2: Apply the configuration to Ch2.</li> </ul>

	set to 'Off Status'.)	<ul style="list-style-type: none"> <li>● CH1&amp;CH2: Apply the configuration to Ch1 and Ch2.</li> </ul>
Digital IO-4 Settings	Function setting of pin 4.	
	Reverse	On/Off, Select Invert or not under the IO Settings. If setting to ON, it means the valid signal is reversed.
	Function	<ul style="list-style-type: none"> <li>● Trigger Out: Configure IO-4 as Trigger Out and enable the triggering output (Trig out) of the List. When the List is triggered to run, IO-4 will output a pulse signal.</li> <li>● Trigger In: Configure the trigger source of the Oscilloscope function, Data recording, and List function to be external. When the instrument receives an external pulse signal, it will trigger the running of the Oscilloscope function, Data Recording function or List function.</li> <li>● Input: Pin 4 receives the level signal from the outside.</li> <li>● Output: Pin 4 sends the digital signal (1, 0) to the outside.</li> </ul>
	Channel (Displayed only when Function is set to 'Trigger'.)	<ul style="list-style-type: none"> <li>● CH1: Apply the configuration to Ch1.</li> <li>● CH2: Apply the configuration to Ch2.</li> <li>● CH1&amp;CH2: Apply the configuration to Ch1 and Ch2.</li> </ul>
Digital IO-5 Settings	Function setting of pin 5.	
	Reverse	On/Off, Select Invert or not under the IO Settings. If setting to ON, it means the valid signal is reversed.
	Function	<ul style="list-style-type: none"> <li>● Inhibit-Living: The power supply will be operated in the mode of Living.</li> <li>● Inhibit-Latch: The power supply will be operated in the mode of Latch.</li> <li>● Input: Pin 5 receives the level signal from the outside.</li> <li>● Output: Pin 5 sends the digital signal (1, 0) to the outside.</li> </ul>
	Channel (Displayed only when Function is set to 'Inhibit'.)	<ul style="list-style-type: none"> <li>● CH1: Apply the configuration to Ch1.</li> <li>● CH2: Apply the configuration to Ch2.</li> <li>● CH1&amp;CH2: Apply the configuration to Ch1 and Ch2.</li> </ul>
Digital IO-6 Settings	Function setting of pin 6.	
	Reverse	On/Off, Select Invert or not under the IO Settings. If setting to ON, it means the valid signal is reversed.
	Function	<ul style="list-style-type: none"> <li>● Sync On: This default function means that pin 6 performs bi-directional and synchronous control over the turn-on of <b>[On/Off]</b>.</li> <li>● Input: Pin 6 receives the level signal from the outside.</li> <li>● Output: Pin 6 sends the digital signal (1, 0) to the outside.</li> </ul>
Digital IO-7 Settings	Function setting of pin 7.	
	Reverse	On/Off, Select Invert or not under the IO Settings. If setting to ON, it means the valid

		signal is reversed.
	Function	<ul style="list-style-type: none"> <li>● Sync Off: This default function means that pin 7 performs bi-directional and synchronous control over the turn-off of <b>[On/Off]</b>.</li> <li>● Input: Pin 7 receives the level signal from the outside.</li> <li>● Output: Pin 7 sends the digital signal (1, 0) to the outside.</li> </ul>

## Signal definition

Digital I/O functions involve input and output levels and pulse signals. The input signal is the control signal provided externally to IT6600, the output signal is the level signal provided externally by IT6600, and the pulse signal is the edge signal switched between high and low levels. The pin signals are defined as follows.

Input signal	High level signal	Typical: 5V Range: 1.6V-15V Current: $\leq 100\text{mA}$
	Low level signal	Typical: 0V Range: -5V-0.8V Current: $\leq 100\text{mA}$
Output signal	High level signal	Voltage level: 5V
	Low level signal	Voltage level: 0V
Pulse	Level rise slew	10us
	Level fall slew	1us
	Width	30us-500us

## Signal Revert

Select Invert or not under the IO Settings menu. If setting to Reverse(Off), it means the default level will be valid. If setting to Reverse(On), it means the valid signal is reversed. For example, the IO-5 pin is inhibit output by default and the high level is valid, when select revert Invert, the low level is valid and the instrument output is disabled.

## 5.9.2 I/O Control

### General Digital I/O Function

- **Digital Input**

Each of the seven pins can be configured as digital input only. Pin 8 is the signal common for the digital input pins. When pins 1 to 7 are configured to Input function, an external signal can be Input to this pin, and the instrument can detect the state of the external signal.

- **Digital Output**

When pins 1 to 7 are configured for the Output function, they can output a high level (False) or low level (True).

- **PWM Output**

Only pins IO-1 and IO-2 can be configured for PWM function, allowing these pins to output PWM signals to external devices. When configured for PWM function, it is necessary to set the values of frequency (Freq) and duty cycle (Duty).

## Digital IO-1

IO-1 pin can be set to [PS Clear], [Input], [Output], [PWM]

The default function is to clear the protected state. When the protection occurs, the protection state can be cleared through this pin, so that the instrument can continue to output normally.

## Digital IO-2

IO-2 pin can be set to [PS], [Input], [Output], [PWM]

The default function is protection state indicator. IO-2 pin will output high or low level based on whether the instrument is under protection or not. Under normal conditions (Not under protection), and when pin 2 is under default setting (Not Invert), pin 2 outputs high level; when the instrument is under protection, pin 2 outputs low level. When pin 2 is set to Invert, the output level is completely opposite.

## Digital IO-3

IO-3 can be set to [OnOff Status], [Input], [Output]

The default function is to indicate the output state of the power supply, in case of output is On, output 5V, otherwise, output 0V.

When pin 3 is set to Invert, the output level is completely opposite.

## Digital IO-4

IO-4 can be set to [Trigger-in], [Trigger-out], [Input],[Output]

- [Trigger-in]: The input trigger signal, the pulse signal sent to the IO-4 pin can be used as the trigger source.

Configure the trigger source of the Oscilloscope function, Data recording, and List function to be external. When the instrument receives an external pulse signal, it will trigger the running of the Oscilloscope function, Data Recording function or List function.

- [Trigger-out]: Configure IO-4 as Trigger Out and enable the triggering output (Trig out) of the List. When the List is triggered to run, IO-4 will output a pulse signal.

## Digital IO-5

IO-5 pin can be set to [Inhibit-latch], [Inhibit-living], [Input], [Output]

The default function is inhibit output. When the IO pin is configured for a Inhibit function and the level signal is low, the output of the machine is forbidden.

Inhibit function has two mode: Latch and Living.

- Living: When input an inhibit signal and the instrument output is turned OFF. The status bar of the LCD screen displays INH warning icon and the output is marked as OFF. If power supply output is ON state before, the ON/OFF button will be lit. When the input signal undoes, the output returns to normal. This function can be used to control the output of the power supply.

- Latch: When input an inhibit signal and the instrument output is turned OFF. The ON/OFF button will be lighted off, the status bar of the LCD screen displays INH warning icon. In this case, user need to remove the input signal and press [Shift]+[Esc] to cleare protection, then manually turn on [On/Off] again.

## Digital IO-6

IO-6 pin can be set to[Sync-on], [Input], [Output]

The default function is used to control and monitor the status of the instrument output On. When the power supply output is off, sending a pulse signal to pin 6 will turn the power supply output on. Additionally, when the power supply output changes from off to on, pin 6 will generate a pulse signal as feedback. This function is mainly used to synchronize the output on of multiple instruments.

Taking three instruments as an example, the operation is as below:

1. Go to the **System**→**IO Config**→**Digital IO-6 Settings** menu.
2. Set pin 6's function of three instruments to **Reverse-Off** and **Sync-On**.
3. Referring to the figure below, connect pin 6 of three instruments.

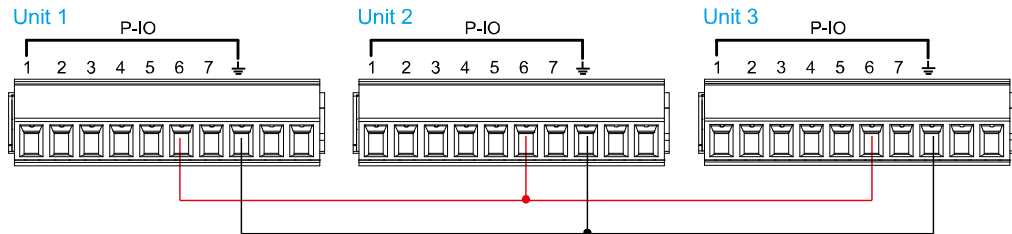

4. Press the **[On/Off]** key of either instrument to switch the output from the Off state to the On state. At this time, the output of the other two instruments will also be turned on synchronously.

## Digital IO-7

IO-7 can be set to [Sync-off], [Input], [Output]

The default function is used to control and monitor the status of the instrument output Off. When the power supply output is on, sending a pulse signal to pin 7 will turn the power supply output off. Additionally, when the power supply output changes from on to off, pin 7 will generate a pulse signal as feedback. This function is mainly used to synchronize the output off of multiple instruments.

Taking three instruments as an example, the operation is as below:

1. Go to the **System**→**IO Config**→**Digital IO-7 Settings** menu.
2. Set pin 7's function of three instruments to **Reverse-Off** and **Sync-Off**.
3. Referring to the figure below, connect pin 7 of three instruments.

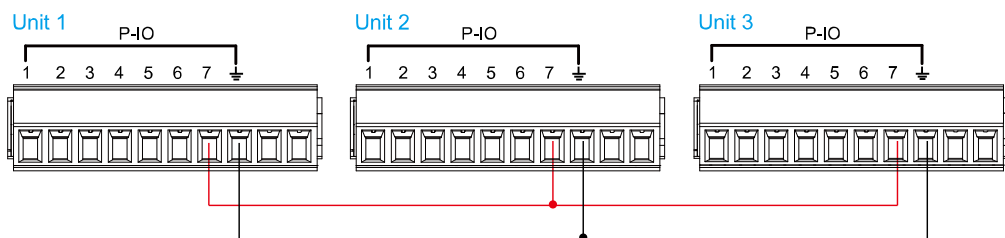

4. Press the **[On/Off]** key of either instrument to switch the output from the On state to the Off state. At this time, the output of the other two instruments

will also be turned off synchronously.

## 5.10 Analogue Function (Ext-Program) (Optional)

The interface expansion slot provided on the rear panel of the IT6600 series. This function is not standard with the instrument and is optional for users.

When the interface card selected by the user is RS232+Analog interface (IT-E177), the analog interface can realize the external analog function.

- Remotely control voltage and current values.
- Remotely control voltage and current upper limit values.
- Remote monitoring of output voltage/current measurement.

### Analog Card Interface Introduction

The pins description is as below.

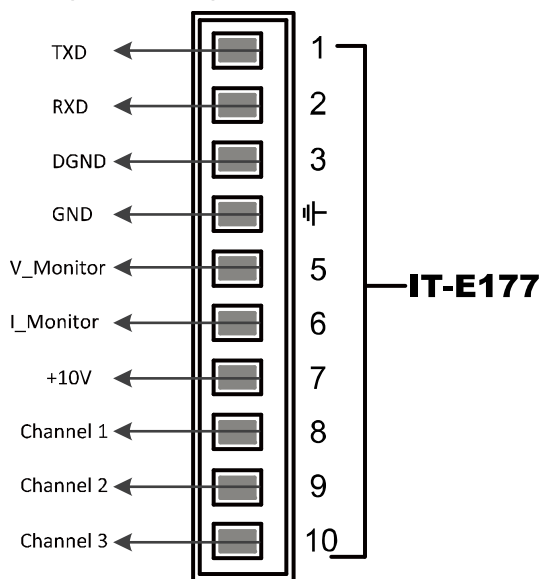

Pins	Name	Description
4 pin	GND	Ground for analog inputs and outputs.
5 pin	V_Monitor	Voltage monitor signal.
6 pin	I_Monitor	Current monitor signal.
7 pin	+10V	The +10V reference voltage output by the power supply can be connected to a resistance subdivision for analog control.
8 pin	Channel 1	The setting for the output voltage/current value corresponds to <b>Volt Set/Curr Set</b> in the menu. <ul style="list-style-type: none"> <li>● CV priority: Specify the value of <b>Vs</b>.</li> <li>● CC priority: Specify the value of <b>Is</b>.</li> </ul>
9 pin	Channel 2	The setting for the voltage/current upper limit corresponds to <b>Volt High/Curr Limit+</b> in the menu. <ul style="list-style-type: none"> <li>● CV priority: Specify the value of the current upper limit <b>I+</b>.</li> <li>● CC priority: Specify the value of the voltage upper limit <b>Vh</b>.</li> </ul>
10 pin	Channel 3	IT6600D series models do not need to be set.

## Enable/disable analog control

The user needs to select the corresponding function settings in the System menu. The detailed parameter description is as below.

External Program	External analog function.(External analog interface is optional.)	
	Status	Set the On/Off state.
	Channel	Select the analog control channel.
Displayed when CV is prioritized.	Volt Set Mx	Indicates the slew factor of Volt Set.
	Volt Set Mb	Indicates the offset of Volt Set.
	Curr Limit+ Mx	Indicates the slew factor of Curr Limit+.
	Curr Limit+ Mb	Indicates the offset of Curr Limit+.
	Curr Limit- Mx	IT6600D series models do not need to be set.
	Curr Limit- Mb	
Displayed when CC is prioritized	Curr Set Mx	Indicates the slew factor of Curr Set.
	Curr Set Mb	Indicates the offset of Curr Set.
	Volt High Set Mx	Indicates the slew factor of Volt Limit+.
	Volt High Set Mb	Indicates the offset of Volt Limit+.
	Volt Low Set Mx	IT6600D series models do not need to be set.
	Volt Low Set Mb	

1. Press the composite keys **[Shift] + [P-set]** (System) on the front panel to enter the system menu.
2. Press the up/down key or rotate the knob to find **Source->External program** menu.
  - i. Set the Set Mx, Set Mb, Limit+ Mx and Limit+ Mb in sequence, and press **[Enter]** to confirm.
  - ii. Press the up/down key to move the cursor to the **Status** function setting and press the **[Enter]** key to confirm. Rotate the knob to select On to turn on the external analog function.
3. Press **[Esc]** to exit.

## Analog Conversion Relationship Introduction

The external analog has three channels, and the parameter configuration for each channel follows a linear function  $y=kx+b$ . The parameter explanations are as follows:

- Independent variable  $x$ : The actual input voltage value of the external analog channel.
- Slew factor  $k$ : Same as Mx in the menu, set by the user.
- Offset  $b$ : Same as Mb in the menu, set by the user.
- $y$ : The actual output value of the instrument. (Voltage when CV is prioritized, current when CC is prioritized)

Taking the **Channel 1**(Volt Set/Curr Set) program setting as an example, the user needs to convert the Mx and Mb values based on the formula below. And set these two values respectively through the front panel keys.



### NOTE

The principle of parameter setting of Channel 1 and Channel 2 is the same, so the description will not be repeated.

- CV priority

$$M_x = \frac{(V_{out2} - V_{out1})}{(V_{in2} - V_{in1})}$$

$$M_b = V_{out2} - V_{in2} \times M_x$$

- CC priority

$$M_x = \frac{(I_{out2} - I_{out1})}{(V_{in2} - V_{in1})}$$

$$M_b = I_{out2} - V_{in2} \times M_x$$

Formula parameter descriptions:

Name	Description
Vin1	Indicates the minimum voltage input to pin 8. The setting range is from -10V to 10.
Vin2	Indicates the maximum voltage input to pin 8. The setting range is from -10V to 10, and Vin2 > Vin1.
Vout1	The minimum value of the output voltage in CV priority mode.
Vout2	The maximum value of the output voltage in CV priority mode, and Vout2 > Vout1.
Iout1	The minimum value of the output current in CC priority mode.
Iout2	The maximum value of the output current in CC priority mode, and Iout2 > Iout1.

## Analog Control

The following is an example of how to connect and use the voltage and current control in CC priority mode.

1. Refer to the figure below to complete the pin connection.

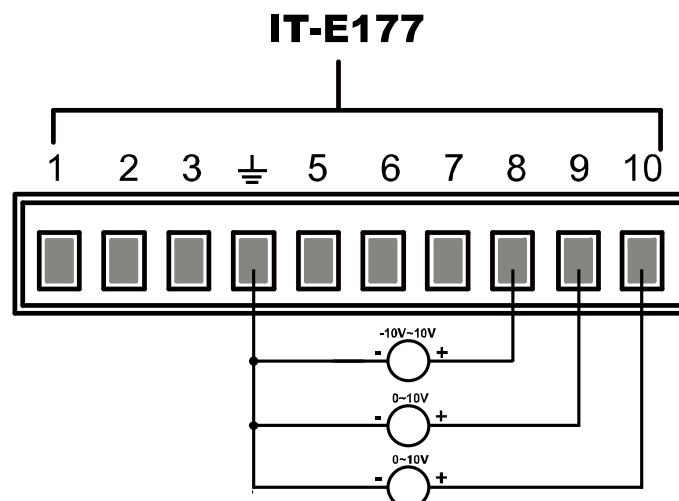

2. Calculate the **M<sub>x</sub>** and **M<sub>b</sub>** under the Curr Set, Volt Limit+, Volt Limit- menus

according to the above formulas. The sample data used in this manual is shown in the table below.

Pin input voltage		Power supply output voltage/current	Mx	Mb	Description
8 pin	Vin1 = 0	Iout1=0	3	0	By inputting a voltage of 0V to 10V to pin 8, the actual output current <b>I<sub>s</sub></b> is controlled from 0A to 30A.
	Vin2 = 10	Iout2=30			
9 pin	Vin1 = 0	V+out1 = 0	100	0	By inputting a voltage of 0V to 5V to pin 9, the actual output voltage upper limit <b>V+</b> is controlled from 0 to 500V.
	Vin2 = 5	V+out2 = 500			

3. Set Mx and Mb of the corresponding pins.
  - 1) Press the composite keys [**Shift**] + [**P-set**] (System) on the front panel to enter the system menu.
  - 2) Press the up/down key or rotate the knob to find **Source->External program** menu.
  - 3) Set the Curr Set Mx, Curr Set Mb, Volt High Set Mx and Volt High Set Mb in sequence, and press [**Enter**] to confirm.
  - 4) Press the up/down key to move the cursor to the **Status** function setting and press the [**Enter**] key to confirm. Rotate the knob to select On to turn on the external analog function.
4. The input for control **pin 8** is 0V to 10V, and the input for control **pin 9** is 0V to 5V.

For example, when the input voltage of Pin 8 is 1V, the setting value of the output current of this instrument is 3A; when the input voltage of Pin 9 is 2V, the setting value of the voltage upper limit **V+** of this instrument is 200V.

## Voltage and current monitoring

The analog interface can monitor the existing output voltage and output current. Connect a digital voltmeter between Pin 5 and Pin 6 of the analog interface and ground wire 4. The voltage reading from 0 to 10V corresponds to the zero to full-scale voltage/current setting of the instrument. The connection diagram is as shown below.

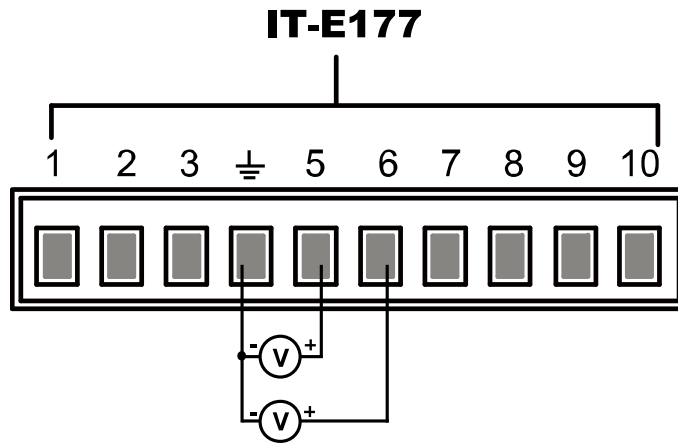

## 5.11 Redundant function

The redundancy function of IT6600D allows observing the status of each cabinet and single unit in parallel mode. When a unit fails, the IT6600D power supply system will automatically identify it, allow the redundant unit to quit the test, and deploy it within the total capacity range to ensure the external output of the entire system.

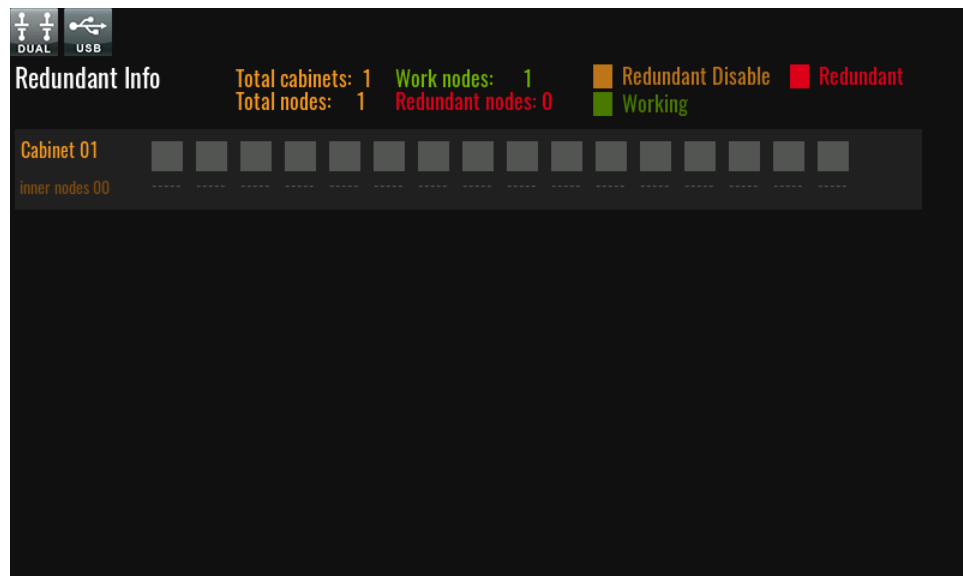

This means that even if one of the units fails, the IT6600D power system will continue to provide full power to the bus as long as the remaining power can meet the test needs. We call it 100% power availability and it's especially suitable for applications with high reliability requirements of power supply.

Click Off Line on the Menu screen to enter the redundant interfaces.



- Total cabinets: total number of cabinets.
- Total nodes: total number of nodes, i.e., total number of machines in parallel.
- Work nodes: The number of working nodes, i.e., the number of machines that are working properly.
- Redundant nodes: The number of redundant nodes, i.e., the number of machines that have failed.
- Redundant Disable: indicates that the redundant function of the current node

has been disabled. The current node displays as .

- Redundant: indicates that the machine in the current node has malfunctioned. The current node displays as .
- Working: indicates that the machine in the current node is operating normally. The current node displays as .
- Inner nodes: the number of internal nodes, i.e. the number of machines contained in a single cabinet.

### WARNING

After the redundant function is enabled, the IT6600D power system adopts a **1+X redundant architecture**. Even if multiple units fail, the system can continue to operate normally as long as at least **one unit** remains functional. However, please note that the output power will decrease proportionally based on the number of available units.

Customers should verify whether the remaining output power is sufficient to meet testing requirements in the event of unit failures. For example, if the system consists of four units and three units fail, the remaining one unit can still maintain operation, but the output power will be only **25%** of the original total.

### Enable/Disable Redundant function

1. Click on **System** in the menu interface to enter the system menu interface.
2. Select **Source -> Redundant Setting** from the system menu.
3. Click the setting located to the right of **Status**, and choose either **On** or **Off** from the dropdown menu.



# Chapter6 Measurement Functions

This chapter describes the characteristics and operations of the basic metering function of IT6600 series source.

## 6.1 Meter Mode

In the **Menu** display interface, click **Meter** to enter the metering interface. See the figure below.

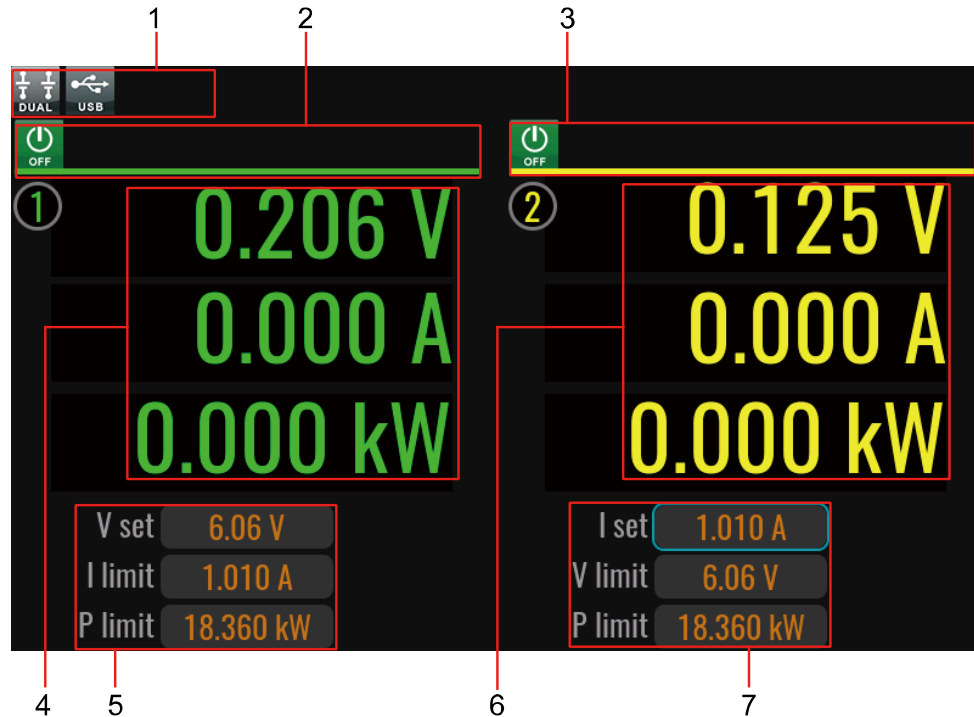

No.	Name	Description
1	Power status bar	Displays the present output status.
2	CH1 status bar	Displays the output status of power channel 1.
3	CH2 status bar	Displays the output status of power channel 2.
4	Output values view area for CH1	Displays the present output voltage, current and power values.
5	Setting values view area for CH1	<ul style="list-style-type: none"> <li>When CV is prioritized, the voltage setting value, current upper limit value, and power upper limit value are displayed.</li> <li>When CC is prioritized, the current setting value, voltage upper limit value, and power upper limit value are displayed.</li> </ul>
6	Output values view area for CH2	Displays the present output voltage, current and power values.

- |   |                                  |  |
|---|----------------------------------|--|
| 7 | Setting values view area for CH2 | <ul style="list-style-type: none"> <li>When CV is prioritized, the voltage setting value, current upper limit value, and power upper limit value are displayed.</li> <li>When CC is prioritized, the current setting value, voltage upper limit value, and power upper limit value are displayed.</li> </ul> |
|---|----------------------------------|--|

## 6.2 Oscilloscope Mode

IT6600 series source has the function of displaying the waveform based on sampling data. The user can select to display or hide the voltage and current waveform of the input unit. Only the necessary waveform is displayed, which can facilitate observation. The waveform display interface includes the vertical axis and horizontal axis.

### Introduction of Waveform Display interface

In the **Menu** display interface, click **Scope** to enter the waveform interface. See the figure below.

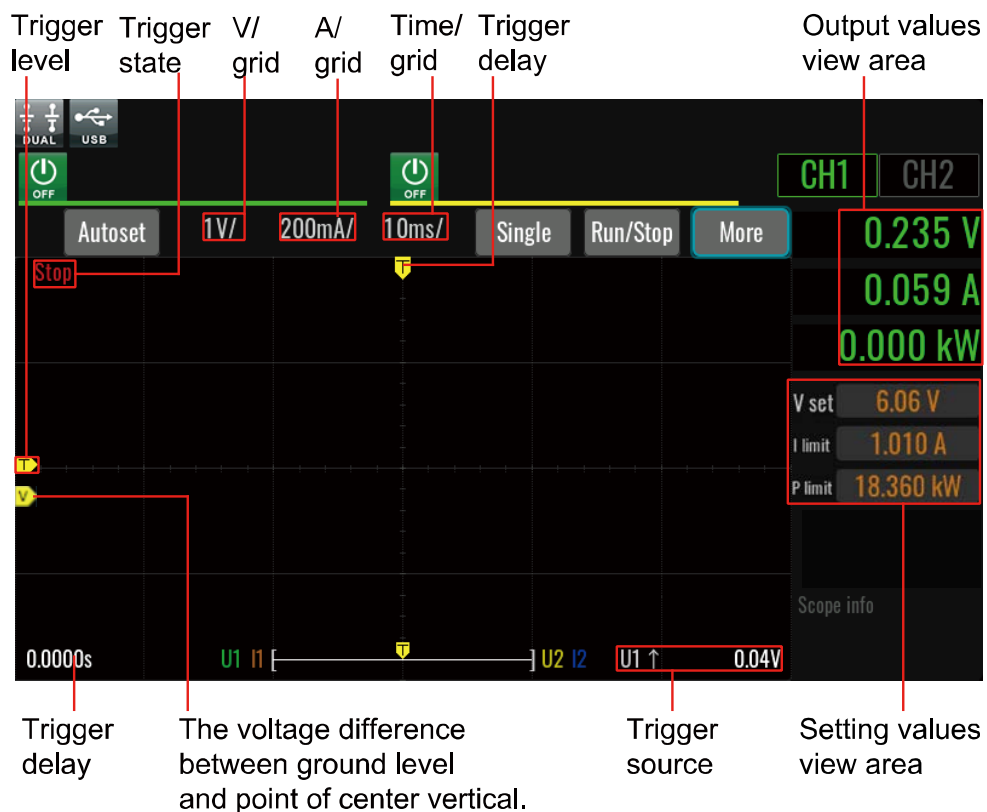

The trigger status is described as follows:

Trigger status	Instruction
Auto	Select the trigger mode as "Auto," with the trigger status displayed as "Auto" when triggered.
Roll	Select the trigger mode as "Auto," with the trigger status displayed as "Roll" when not triggered.
Trig	Select the trigger mode as "Normal," with the trigger status displayed as "Trig" when triggered.
Ready	Select the trigger mode as "Normal," with the trigger status

	displayed as "Ready" when not triggered.
Stop	When the "Stop" key in the waveform display interface is pressed, the trigger status Stop will be displayed.

#### Description of keys on the waveform display interface:

- AutoSet: Automatically adjust the appropriate time base, voltage/current scale, and restore the trigger level and trigger delay to default values.
- Voltage/Current/Time: Adjust voltage/current/time base range.
- Single: Single measurement key: when single measurement is enabled in the Stop status, the stop status is enabled again after one measurement based on the current data updating rate. When single measurement is enabled in the Ready status, the instrument immediately restarts one measurement and then enters the Stop status.
- Run/Stop: press the corresponding soft key to run or stop the waveform status.
- More: Advanced configuration options for oscilloscope function.

Parameter	Description
Trigger source	<p>Select trigger source, Voltage, Current and External can be select.</p> <ul style="list-style-type: none"> <li>● Voltage trigger. When the DC terminals detect that the voltage reaches the trigger voltage setting value and is within the range of the upper and lower trigger limits, a data recording operation is triggered.                             <ul style="list-style-type: none"> <li>➤ Trig Level: Trigger threshold.</li> <li>➤ Edge: Select trigger edge: rising edge (Rise), descending edge (Fall) or either edge (Both).</li> <li>➤ Trig High: Trigger upper limit value.</li> <li>➤ Trig Low: Trigger lower limit value.</li> </ul> </li> <li>● Current trigger. When the DC terminals detect that the current reaches the trigger current setting value and is within the range of the upper and lower trigger limits, a data recording operation is triggered.                             <ul style="list-style-type: none"> <li>➤ Trig Level: Trigger threshold.</li> <li>➤ Edge: Select trigger edge: rising edge (Rise), descending edge (Fall) or either edge (Both).</li> <li>➤ Trig High: Trigger upper limit value.</li> <li>➤ Trig Low: Trigger lower limit value.</li> </ul> </li> <li>● External: Indicates the trigger occurs via the pin 4 of the digital I/O interface (P-IO). For details, see <a href="#">5.9 Digital I/O Function</a>.</li> </ul>
Trigger mode	Auto and Normal can be select.
Print data	<p>Save the data.</p> <ul style="list-style-type: none"> <li>● Depth: data record depth.</li> <li>● Algorithm: with the option of Normal or Peak.</li> </ul>

---

Line selection	Select the displayed curve, which is used to select whether to display the voltage/current waveform of the corresponding channel. Up to 4 oscillographic data curves can be displayed.
----------------	--

---

## Trigger waveform

When the specified trigger conditions are satisfied, the trigger waveform will be displayed. The triggering time is the trigger point, generally on the middle of the screen. When the trigger point is reached, the screen will display the waveform from left to right over time. The user should set the following parameters before using the trigger function.

- **Trigger mode**

The trigger mode refers to the condition to update the contents on the screen. It is divided into the Auto mode and Normal mode. In the Auto mode, the displayed waveform will be updated when triggering occurs in the suspension time; otherwise, the displayed waveform will be updated automatically.

In the Normal mode, the displayed waveform will be updated in the case of triggering and not updated in the case of no triggering.

- **Trigger source**

The trigger source is used for generating trigger conditions.

- **Trigger edge**

The edge refers to the change of the signal from low level to high level (rising edge) or from high level to low level (falling edge). The edge used as a trigger condition is referred to as the trigger edge.

- **Trigger level**

The trigger level refers to the level which the trigger edge passes through. If the signal of the trigger source passes through the set trigger level according to the specified trigger edge, triggering occurs.

When "U↑" is selected for editing, you can adjust the trigger level using the knob, number keys, or arrow keys. In this case, the trigger level can be changed by rotating the knob and you can observe trigger level changes on the screen.

## Horizontal Control and Vertical Control

- **Vertical calibration**

When V/grid or A/grid is selected, you can rotate the knob to set the voltage or current range of each interval.

- **Horizontal calibration**

When Time/grid is selected, you can rotate the knob to adjust the horizontal scale (scanning speed). When the horizontal (time/scale) setting is changed by rotating the knob, you can observe the change of time/scale on the screen.

- **Trigger delay**

You can adjust the trigger delay using the editing box (knob/directional keys/numeric keys) or by horizontal sliding. The default trigger delay is 0,

which positions the trigger point (📌) in the middle of the waveform display area. When the trigger delay value is positive, the trigger point moves to the left; when it is negative, the trigger point moves to the right.

## Print data

In the **More** menu, users can select the **Print Data** item and select the data logging mode. Data of oscilloscope interface will be recorded to U disk.

Print data mode:

- Off: turn off the print data function.
- Post: Record the position data of the waveform.
- Raw: The recorded data is original data, The default data sampling interval is 10us.
- Both: Post and Raw, record two data file.

## 6.3 Recorder Function

The data recording function allows you to observe and record output status data for a long time. On the recorder interface, you can select a maximum of six data curves to be displayed.

In the **Menu** display interface, click **Recorder** to enter the data recording function interface. See the figure below.

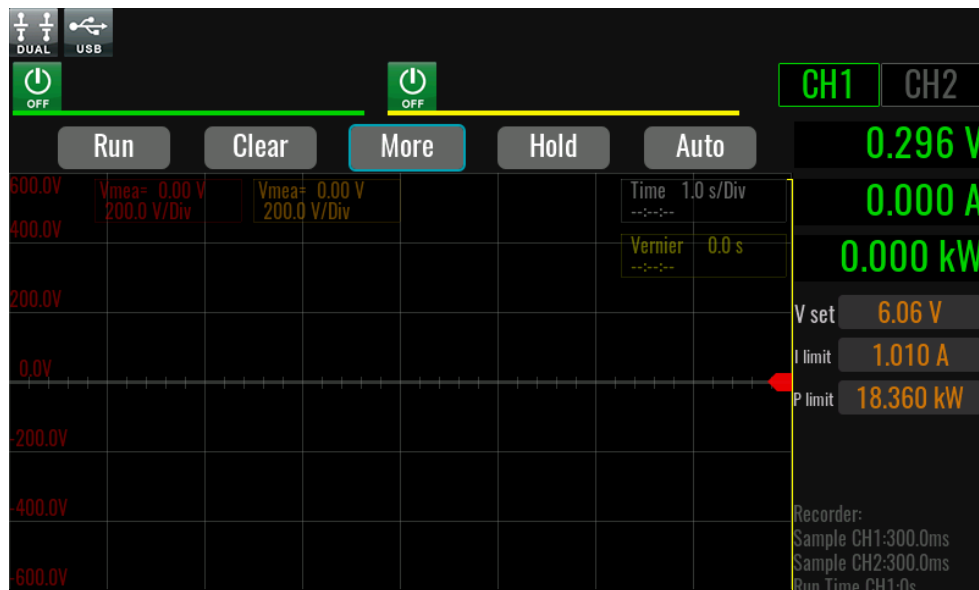

- Run/Stop: Run/Stop refresh data.
- Clean: Clean all of data curve.
- More: Enter to the advanced menu to set more parameters.

Parameter	Description
Viewing control	Select the number of data curves currently displayed and the corresponding parameters. Up to six curves can be displayed, with optional parameters including Vmean, Vmin, Vmax, Imean, Imin, Imax, Pmean, Pmin, Pmax.

Record objects(Dlog)	<p>Select the data objects to be recorded.</p> <ul style="list-style-type: none"> <li>● Run state: Enable or disable storage status. If disabled, all data will not be saved or displayed.</li> <li>● Voltage: Enable or disable voltage storage.</li> <li>● Current: Enable or disable current storage.</li> <li>● Power: Enable or disable power storage.</li> </ul>
Trigger settings	<p>Select the trigger source of the recorder function, including Immediate, Manual, Bus, Voltage, Current, and External.</p> <ul style="list-style-type: none"> <li>● Immediate: Perform a trigger operation immediately.</li> <li>● Manual: Indicates the trigger occurs when the <b>[Shift]+[5]</b>(Trigger) keys are pressed from the front panel.</li> <li>● Bus: Bus trigger. When the trigger command <b>*TRG</b> is received, the instrument generates a trigger.</li> <li>● Voltage trigger. When the DC terminals detect that the voltage reaches the trigger voltage setting value and is within the range of the upper and lower trigger limits, a data recording operation is triggered.                         <ul style="list-style-type: none"> <li>➢ Trig Level: Trigger threshold.</li> <li>➢ Edge: Select trigger edge: rising edge (Rise), descending edge (Fall) or either edge (Both).</li> <li>➢ Trig High: Trigger upper limit value.</li> <li>➢ Trig Low: Trigger lower limit value.</li> </ul> </li> <li>● Current trigger. When the DC terminals detect that the current reaches the trigger current setting value and is within the range of the upper and lower trigger limits, a data recording operation is triggered.                         <ul style="list-style-type: none"> <li>➢ Trig Level: Trigger threshold.</li> <li>➢ Edge: Select trigger edge: rising edge (Rise), descending edge (Fall) or either edge (Both).</li> <li>➢ Trig High: Trigger upper limit value.</li> <li>➢ Trig Low: Trigger lower limit value.</li> </ul> </li> <li>● External: Indicates the trigger occurs via the pin 4 of the digital I/O interface (P-IO). For details, see <a href="#">5.9 Digital I/O Function</a>.</li> </ul>
Run time	<p>This parameter indicates the time for data recording (unit: s), namely, the data recording will be completed in Y seconds and be ready for the next data record. The input range supported by the instrument is: 0-9999999s.</p>
Sampling period	<p>This parameter indicates the data sampling interval (unit: ms), that is, the test data is recorded once every X seconds. The input range supported by the instrument is: 0.1ms-1000ms.</p>
File format	<p>Select the file format, include Tdms and CSV.</p>

- Hold-On/Hold-Off: Pause screen data refresh (for data observation)/ Start dynamically observing the data.
- Auto: Automatically adjusts the scale of the appropriate vertical axis.
- Time: The time value of each of the horizontal coordinates, unit is s/Div
- Vernier: Position information of the vernier caliper.

## Chapter7 Technical Specifications

This chapter will introduce the main technical parameters of this power, such as rated voltage/current/power and so on. Besides, this part will introduce the working environment and storage temperature.

### 7.1 Supplemental characteristics

Recommended calibration frequency: once a year

Cooling style: fans

### 7.2 Main technical parameters

#### IT6642D-1200-200

Parameter		IT6642D-1200-200	
Rated value	Voltage	Series mode	0~1200V
		2-channel mode/Parallel mode	0~600V
	Current	Parallel mode	0~200A
		2-channel mode/Series mode	0~100A
	Power	Each channel	0~21kW
		Total	0~42kW
	Resistance in series (CV priority)	2-channel mode	0~0.6Ω
		Parallel mode	0~0.3Ω
		Series mode	0~1.2Ω
	Load resistance (CC priority)	2-channel mode	0.046~7500Ω
Parallel mode		0.023~7500Ω	
Series mode		0.092~7500Ω	
Line Regulation	Voltage	≤0.005%FS	
	Current	≤0.005%FS	
Load Regulation	Voltage	≤0.005%FS	
	Current	≤0.015%FS	
Setup Resolution	Voltage	0.001V	
	Current	0.001A	
	Power	0.001kW	
	Resistance	0.001Ω	
Read Back Resolution	Voltage	0.001V	
	Current	0.001A	
	Power	0.001kW	
Setup Accuracy	Voltage	≤0.02%+0.01%FS	
	Current	≤0.03% + 0.03%FS	
	Power	≤0.05% + 0.15%FS	
	Resistance *1	≤0.5%	
Read Back Accuracy	Voltage	≤0.02%+0.01%FS	
	Current	≤0.03% + 0.03%FS	
	Power	≤0.05% + 0.15%FS	

	Resistance *1	≤0.5%	
Ripple *2	Vpp	20Hz-20MHz	≤0.1%FS
	Vrms	20Hz-20MHz	≤0.02%FS
	Irms	20Hz-300KHz	≤0.1%FS
Setup Temperature Coefficient	Voltage	≤15PPM/°C	
	Current	≤30PPM/°C	
Read Back Temperature Coefficient	Voltage	≤15PPM/°C	
	Current	≤30PPM/°C	
Rise Time( no load )	Voltage	≤1ms	
Rise Time( full load )	Voltage	≤1ms	
Fall Time( no load )	Voltage	≤1s	
Fall Time( full load )	Voltage	≤100ms	
Rise Time( full current )	Current	≤1ms	
Fall Time( full current )	Current	≤1ms	
Transient Response Time (change from 40% to 90% of rated current)	Voltage	≤200us	
AC Input	Input voltage *3	Three phase + PE	21 kW Max. @180-264V-Input 42 kW Max. @342-528V-Input
		Maximum Input Current	73A(per phase)@200Vac, 3ø input 77A(per phase)@380Vac, 3ø input 61A(per phase)@480Vac, 3ø input
	Maximum Input Apparent Power	45.4kVA	
	Frequency	47Hz~63Hz	
	Power Factor *4	0.99	
	Setup Stability-30min	Voltage	≤0.005%+0.005%FS
Current		≤0.01%+0.01%FS	
Setup Stability-8h	Voltage	≤0.005%+0.005%FS	
	Current	≤0.01%+0.01%FS	
Readback Stability-30min	Voltage	≤0.005%+0.005%FS	
	Current	≤0.01%+0.01%FS	
Readback Stability-8h	Voltage	≤0.005%+0.005%FS	
	Current	≤0.01%+0.01%FS	
Efficiency	Full current and full power	~93.5%	
	Full voltage and full power	~94%	
Output Port Capacitance	2-channel mode	58.4uF/CH	
Remote Sense Voltage	1%FS		
Command Response Time	1ms		
Storage Temperature	-10°C~70°C		
Protective Function	OVP, OCP, OPP, UVP, UCP, OTP, Vsense protection		
Standard Interface	Standard: USB, CAN, LAN, Digital IO Optional: GPIB, Analog/RS232), fiber optic socket, EtherCAT card, Relay cards		
Isolation (output to ground)	2250V		
Working Temperature *5	0~50°C		
IP	IP20		
Safety Standard	IEC 61010		

Cooling	Air
Dimension (mm)	483mm(W)* 151.3mm(H)* 831.6mm(D)
Weight( net)	50kg

\*1. This accuracy specification applies to output power in the range of 10% to 100%. When the output power is low, the resistance deviation ( $\Delta R$ ) can be approximated by:  $\Delta R \approx V / (V/R_{set} - \Delta I) - R_{set}$ . where  $V$  is the external voltage,  $R_{set}$  is the set resistance value, and  $\Delta I$  is the theoretical current deviation of the IT6600.

\*2. This specification was tested under test conditions with an output voltage of  $\geq 30V$ .

\*3. Multi-master cabinet, that is, optional emergency stop module (including AC contactor) models, the standard AC input voltage only supports  $380VAC \pm 10\%$ , such as the need for  $480VAC \pm 10\%$  voltage need to be customized.

\*4. Power factor of 0.99 at 50% of rated power and above at nominal input.

\*5. When the unit temperature exceeds  $40^{\circ}C$ , the rated current and power decrease by 3% for every  $1^{\circ}C$  increase. When the cabinet temperature exceeds  $30^{\circ}C$ , they decrease by 2% for every  $1^{\circ}C$  increase. Both are applicable up to a maximum of  $50^{\circ}C$ .

## IT6684D-1200-400

Parameter		IT6684D-1200-400	
Rated value	Voltage	Series mode	0 ~ 1200V
		2-channel mode/Parallel mode	0 ~ 600V
	Current	Parallel mode	0 ~ 400A
		2-channel mode/Series mode	0 ~ 200A
	Power	Each channel	0 ~ 42kW
		Total	0 ~ 84kW
	Resistance in series (CV priority)	2-channel mode	0 ~ 0.3 $\Omega$
		Parallel mode	0 ~ 0.15 $\Omega$
		Series mode	0 ~ 0.6 $\Omega$
	Load resistance (CC priority)	2-channel mode	0.023 ~ 7500 $\Omega$
Parallel mode		0.012 ~ 7500 $\Omega$	
Series mode		0.046 ~ 7500 $\Omega$	
Line Regulation	Voltage	$\leq 0.005\%FS$	
	Current	$\leq 0.005\%FS$	
Load Regulation	Voltage	$\leq 0.005\%FS$	
	Current	$\leq 0.015\%FS$	
Setup Resolution	Voltage	0.001V	
	Current	0.001A	
	Power	0.001kW	
	Resistance	0.001 $\Omega$	
Read Back Resolution	Voltage	0.001V	
	Current	0.001A	
	Power	0.001kW	
Setup Accuracy	Voltage	$\leq 0.02\% + 0.01\%FS$	
	Current	$\leq 0.03\% + 0.03\%FS$	
	Power	$\leq 0.05\% + 0.15\%FS$	
	Resistance *1	$\geq 0.5\%$	

Read Back Accuracy	Voltage	$\leq 0.02\% + 0.01\%FS$	
	Current	$\leq 0.03\% + 0.03\%FS$	
	Power	$\leq 0.05\% + 0.15\%FS$	
	Resistance *1	$\geq 0.5\%$	
Ripple *2	Vpp	20Hz-20MHz	$\leq 0.11\%FS$
	Vrms	20Hz-20MHz	$\leq 0.022\%FS$
	Irms	20Hz-300KHz	$\leq 0.11\%FS$
Setup Temperature Coefficient	Voltage	$\leq 15PPM/^{\circ}C$	
	Current	$\leq 30PPM/^{\circ}C$	
Read Back Temperature Coefficient	Voltage	$\leq 15PPM/^{\circ}C$	
	Current	$\leq 30PPM/^{\circ}C$	
Rise Time (no load)	Voltage	$\leq 1ms$	
Rise Time (full load)	Voltage	$\leq 1ms$	
Fall Time (no load)	Voltage	$\leq 1s$	
Fall Time (full load)	Voltage	$\leq 100ms$	
Rise Time (Full current)	Current	$\leq 1ms$	
Fall Time (Full current)	Current	$\leq 1ms$	
Transient Response Time (change from 40% to 90% of rated current)	Voltage	$\leq 200us$	
AC Input	Input voltage *3	Three phase +PE	42 kW Max. @180-264V-Input 84 kW Max. @342-528V-Input
		Maximum Input Current	146A(per phase)@200Vac, 3 $\phi$ input 154A(per phase)@380Vac, 3 $\phi$ input 122A(per phase)@480Vac, 3 $\phi$ input
	Maximum Input Apparent Power	90.8kVA	
	Frequency	47Hz~63Hz	
	Power Factor *4	0.99	
	Setup Stability-30min	Voltage	$\leq 0.005\% + 0.005\%FS$
Current		$\leq 0.01\% + 0.01\%FS$	
Setup Stability-8h	Voltage	$\leq 0.005\% + 0.005\%FS$	
	Current	$\leq 0.01\% + 0.01\%FS$	
Readback Stability-30min	Voltage	$\leq 0.005\% + 0.005\%FS$	
	Current	$\leq 0.01\% + 0.01\%FS$	
Readback Stability-8h	Voltage	$\leq 0.005\% + 0.005\%FS$	
	Current	$\leq 0.01\% + 0.01\%FS$	
Efficiency	Full current and full power	$\sim 93.5\%$	
	Full voltage and full power	$\sim 94\%$	
Output Capacitance	2-channel mode	116.8uF/CH	
Remote Sense Voltage	1%FS		
Command Response Time	1ms		
Storage Temperature	$-10^{\circ}C \sim 70^{\circ}C$		
Protective Function	OVP, OCP, OPP, UVP, UCP, OTP, Vsense protection		
Standard Interface	Standard: USB, CAN, LAN, Digital IO Optional: GPIB, Analog/RS232), fiber optic socket, EtherCAT card, Relay cards		
Isolation (output to ground)	2250V		
Working Temperature *5	$0 \sim 50^{\circ}C$		

IP	IP20
Safety Standard	IEC 61010
Cooling	Air
Dimension ( mm)	500mm(W)* 907.64mm(H)* 841.1mm(D) (Depth 1008.1mm including protective cover)
Weight( net)	186kg

\*1. This accuracy specification applies to output power in the range of 10% to 100%. When the output power is low, the resistance deviation ( $\Delta R$ ) can be approximated by:  $\Delta R \approx V / (V/R_{set} - \Delta I) - R_{set}$ . where  $V$  is the external voltage,  $R_{set}$  is the set resistance value, and  $\Delta I$  is the theoretical current deviation of the IT6600.

\*2. This specification was tested under test conditions with an output voltage of  $\geq 30V$ .

\*3. Multi-master cabinet, that is, optional emergency stop module (including AC contactor) models, the standard AC input voltage only supports 380VAC  $\pm 10\%$ , such as the need for 480VAC  $\pm 10\%$  voltage need to be customized.

\*4. Power factor of 0.99 at 50% of rated power and above at nominal input.

\*5. When the unit temperature exceeds 40°C, the rated current and power decrease by 3% for every 1°C increase. When the cabinet temperature exceeds 30°C, they decrease by 2% for every 1°C increase. Both are applicable up to a maximum of 50°C.

## IT66126D-1200-600

Parameter		IT66126D-1200-600	
Rated value	Voltage	Series mode	0 ~ 1200V
		2-channel mode/Parallel mode	0 ~ 600V
	Current	Parallel mode	0 ~ 600A
		2-channel mode/Series mode	0 ~ 300A
	Power	Each channel	0 ~ 63kW
		Total	0 ~ 126kW
	Resistance in series (CV priority)	2-channel mode	0 ~ 0.2 $\Omega$
		Parallel mode	0 ~ 0.1 $\Omega$
		Series mode	0 ~ 0.4 $\Omega$
	Load resistance (CC priority)	2-channel mode	0.016 ~ 7500 $\Omega$
Parallel mode		0.008 ~ 7500 $\Omega$	
Series mode		0.031 ~ 7500 $\Omega$	
Line Regulation	Voltage	$\leq 0.005\%FS$	
	Current	$\leq 0.005\%FS$	
Load Regulation	Voltage	$\leq 0.005\%FS$	
	Current	$\leq 0.015\%FS$	
Setup Resolution	Voltage	0.001V	
	Current	0.001A	
	Power	0.001kW	
	Resistance	0.001 $\Omega$	
Read Back Resolution	Voltage	0.001V	
	Current	0.001A	
	Power	0.001kW	
Setup Accuracy	Voltage	$\leq 0.02\% + 0.01\%FS$	

	Current	$\leq 0.03\% + 0.03\%FS$	
	Power	$\leq 0.05\% + 0.15\%FS$	
	Resistance *1	$\geq 0.5\%$	
Read Back Accuracy	Voltage	$\leq 0.02\% + 0.01\%FS$	
	Current	$\leq 0.03\% + 0.03\%FS$	
	Power	$\leq 0.05\% + 0.15\%FS$	
Ripple *2	Resistance *1	$\geq 0.5\%$	
	Vpp	20Hz-20MHz	$\leq 0.12\%FS$
	Vrms	20Hz-20MHz	$\leq 0.024\%FS$
Setup Temperature Coefficient	Irms	20Hz-300KHz	$\leq 0.12\%FS$
	Voltage	$\leq 15PPM/^{\circ}C$	
	Current	$\leq 30PPM/^{\circ}C$	
Read Back Temperature Coefficient	Voltage	$\leq 15PPM/^{\circ}C$	
	Current	$\leq 30PPM/^{\circ}C$	
Rise Time (no load)	Voltage	$\leq 1ms$	
Rise Time (full load)	Voltage	$\leq 1ms$	
Fall Time (no load)	Voltage	$\leq 1s$	
Fall Time (full load)	Voltage	$\leq 100ms$	
Rise Time (Full current)	Current	$\leq 1ms$	
Fall Time (Full current)	Current	$\leq 1ms$	
Transient Response Time (change from 40% to 90% of rated current)	Voltage	$\leq 200us$	
AC Input	Input voltage *3	Three phase +PE	63 kW Max. @180-264V-Input
			126 kW Max. @342-528V-Input
	Maximum Input Current	219A(per phase)@200Vac, 3 $\phi$ input	
		230A(per phase)@380Vac, 3 $\phi$ input	
		182A(per phase)@480Vac, 3 $\phi$ input	
Maximum Input Apparent Power	136.2kVA		
Frequency	47Hz~63Hz		
Power Factor *4	0.99		
Setup Stability-30min	Voltage	$\leq 0.005\% + 0.005\%FS$	
	Current	$\leq 0.01\% + 0.01\%FS$	
Setup Stability-8h	Voltage	$\leq 0.005\% + 0.005\%FS$	
	Current	$\leq 0.01\% + 0.01\%FS$	
Readback Stability-30min	Voltage	$\leq 0.005\% + 0.005\%FS$	
	Current	$\leq 0.01\% + 0.01\%FS$	
Readback Stability-8h	Voltage	$\leq 0.005\% + 0.005\%FS$	
	Current	$\leq 0.01\% + 0.01\%FS$	
Efficiency	Full current and full power	$\sim 93.5\%$	
	Full voltage and full power	$\sim 94\%$	
Output Capacitance	2-channel mode	175.2uF/CH	
Remote Sense Voltage	1%FS		
Command Response Time	1ms		
Storage Temperature	$-10^{\circ}C \sim 70^{\circ}C$		
Protective Function	OVP, OCP, OPP, UVP, UCP, OTP, Vsense protection		

Standard Interface	Standard: USB, CAN, LAN, Digital IO Optional: GPIB, Analog/RS232), fiber optic socket, EtherCAT card, Relay cards
Isolation (output to ground)	2250V
Working Temperature *5	0~50°C
IP	IP20
Safety Standard	IEC 61010
Cooling	Air
Dimension ( mm)	500mm(W)* 907.64mm(H)* 841.1mm(D) (Depth 1008.1mm including protective cover)
Weight( net)	237kg

\*1. This accuracy specification applies to output power in the range of 10% to 100%. When the output power is low, the resistance deviation ( $\Delta R$ ) can be approximated by:  $\Delta R \approx V / (V/R_{set} - \Delta I) - R_{set}$ . where  $V$  is the external voltage,  $R_{set}$  is the set resistance value, and  $\Delta I$  is the theoretical current deviation of the IT6600.

\*2. This specification was tested under test conditions with an output voltage of  $\geq 30V$ .

\*3. Multi-master cabinet, that is, optional emergency stop module (including AC contactor) models, the standard AC input voltage only supports 380VAC  $\pm 10\%$ , such as the need for 480VAC  $\pm 10\%$  voltage need to be customized.

\*4. Power factor of 0.99 at 50% of rated power and above at nominal input.

\*5. When the unit temperature exceeds 40°C, the rated current and power decrease by 3% for every 1°C increase. When the cabinet temperature exceeds 30°C, they decrease by 2% for every 1°C increase. Both are applicable up to a maximum of 50°C.

## IT66168D-1200-800

Parameter		IT66168D-1200-800	
Rated value	Voltage	Series mode	0 ~ 1200V
		2-channel mode/Parallel mode	0 ~ 600V
	Current	Parallel mode	0 ~ 800A
		2-channel mode/Series mode	0 ~ 400A
	Power	Each channel	0 ~ 84kW
		Total	0 ~ 168kW
	Resistance in series (CV priority)	2-channel mode	0 ~ 0.15Ω
		Parallel mode	0 ~ 0.075Ω
		Series mode	0 ~ 0.3Ω
	Load resistance (CC priority)	2-channel mode	0.012 ~ 7500Ω
Parallel mode		0.006 ~ 7500Ω	
Series mode		0.023 ~ 7500Ω	
Line Regulation	Voltage	$\leq 0.005\%FS$	
	Current	$\leq 0.005\%FS$	
Load Regulation	Voltage	$\leq 0.005\%FS$	
	Current	$\leq 0.015\%FS$	
Setup Resolution	Voltage	0.001V	
	Current	0.001A	
	Power	0.001kW	

	Resistance	0.001Ω	
Read Back Resolution	Voltage	0.001V	
	Current	0.001A	
	Power	0.001kW	
Setup Accuracy	Voltage	$\leq 0.02\% + 0.01\%FS$	
	Current	$\leq 0.03\% + 0.03\%FS$	
	Power	$\leq 0.05\% + 0.15\%FS$	
	Resistance *1	$\geq 0.5\%$	
Read Back Accuracy	Voltage	$\leq 0.02\% + 0.01\%FS$	
	Current	$\leq 0.03\% + 0.03\%FS$	
	Power	$\leq 0.05\% + 0.15\%FS$	
	Resistance *1	$\geq 0.5\%$	
Ripple *2	Vpp	20Hz-20MHz	$\leq 0.13\%FS$
	Vrms	20Hz-20MHz	$\leq 0.026\%FS$
	Irms	20Hz-300KHz	$\leq 0.13\%FS$
Setup Temperature Coefficient	Voltage	$\leq 15PPM/^{\circ}C$	
	Current	$\leq 30PPM/^{\circ}C$	
Read Back Temperature Coefficient	Voltage	$\leq 15PPM/^{\circ}C$	
	Current	$\leq 30PPM/^{\circ}C$	
Rise Time (no load)	Voltage	$\leq 1ms$	
Rise Time (full load)	Voltage	$\leq 1ms$	
Fall Time (no load)	Voltage	$\leq 1s$	
Fall Time (full load)	Voltage	$\leq 100ms$	
Rise Time (Full current)	Current	$\leq 1ms$	
Fall Time (Full current)	Current	$\leq 1ms$	
Transient Response Time (change from 40% to 90% of rated current)	Voltage	$\leq 200us$	
AC Input	Input voltage *3	Three phase +PE	84 kW Max. @180-264V-Input
			168 kW Max. @342-528V-Input
	Maximum Input Current	292A(per phase)@200Vac, 3ø input	
		307A(per phase)@380Vac, 3ø input	
		243A(per phase)@480Vac, 3ø input	
	Maximum Input Apparent Power	181.5kVA	
Frequency	47Hz~63Hz		
Power Factor *4	0.99		
Setup Stability-30min	Voltage	$\leq 0.005\% + 0.005\%FS$	
	Current	$\leq 0.01\% + 0.01\%FS$	
Setup Stability-8h	Voltage	$\leq 0.005\% + 0.005\%FS$	
	Current	$\leq 0.01\% + 0.01\%FS$	
Readback Stability-30min	Voltage	$\leq 0.005\% + 0.005\%FS$	
	Current	$\leq 0.01\% + 0.01\%FS$	
Readback Stability-8h	Voltage	$\leq 0.005\% + 0.005\%FS$	
	Current	$\leq 0.01\% + 0.01\%FS$	
Efficiency	Full current and full power	~93.5%	
	Full voltage and full power	~94%	
Output Capacitance	2-channel mode	233.6uF/CH	
Remote Sense Voltage	1%FS		

Command Response Time	1ms
Storage Temperature	-10°C ~ 70°C
Protective Function	OVP, OCP, OPP, UVP, UCP, OTP, Vsense protection
Standard Interface	Standard: USB, CAN, LAN, Digital IO Optional: GPIB, Analog/RS232), fiber optic socket, EtherCAT card, Relay cards
Isolation (output to ground)	2250V
Working Temperature *5	0 ~ 50°C
IP	IP20
Safety Standard	IEC 61010
Cooling	Air
Dimension ( mm)	600mm(W)* 1441.41mm(H)* 840.1mm(D) (Depth 1008.1mm including protective cover)
Weight( net)	346kg

\*1. This accuracy specification applies to output power in the range of 10% to 100%. When the output power is low, the resistance deviation ( $\Delta R$ ) can be approximated by:  $\Delta R \approx V / (V/R_{set} - \Delta I) - R_{set}$ . where  $V$  is the external voltage,  $R_{set}$  is the set resistance value, and  $\Delta I$  is the theoretical current deviation of the IT6600.

\*2. This specification was tested under test conditions with an output voltage of  $\geq 30V$ .

\*3. Multi-master cabinet, that is, optional emergency stop module (including AC contactor) models, the standard AC input voltage only supports 380VAC  $\pm 10\%$ , such as the need for 480VAC  $\pm 10\%$  voltage need to be customized.

\*4. Power factor of 0.99 at 50% of rated power and above at nominal input.

\*5. When the unit temperature exceeds 40°C, the rated current and power decrease by 3% for every 1°C increase. When the cabinet temperature exceeds 30°C, they decrease by 2% for every 1°C increase. Both are applicable up to a maximum of 50°C.

## IT66210D-1200-1000

Parameter		IT66210D-1200-1000	
Rated value	Voltage	Series mode	0 ~ 1200V
		2-channel mode/Parallel mode	0 ~ 600V
	Current	Parallel mode	0 ~ 1000A
		2-channel mode/Series mode	0 ~ 500A
	Power	Each channel	0 ~ 105kW
		Total	0 ~ 210kW
	Resistance in series (CV priority)	2-channel mode	0 ~ 0.12Ω
		Parallel mode	0 ~ 0.06Ω
		Series mode	0 ~ 0.24Ω
	Load resistance (CC priority)	2-channel mode	0.01 ~ 7500Ω
Parallel mode		0.005 ~ 7500Ω	
Series mode		0.019 ~ 7500Ω	
Line Regulation	Voltage	$\leq 0.01\%FS$	
	Current	$\leq 0.01\%FS$	
Load Regulation	Voltage	$\leq 0.01\%FS$	
	Current	$\leq 0.02\%FS$	

Setup Resolution	Voltage	0.001V	
	Current	0.01A	
	Power	0.001kW	
	Resistance	0.001Ω	
Read Back Resolution	Voltage	0.001V	
	Current	0.01A	
	Power	0.001kW	
Setup Accuracy	Voltage	≤0.02%+0.02%FS	
	Current	≤0.03% + 0.03%FS	
	Power	≤0.05% + 0.15%FS	
	Resistance *1	≥0.5%	
Read Back Accuracy	Voltage	≤0.02%+0.02%FS	
	Current	≤0.03% + 0.03%FS	
	Power	≤0.05% + 0.15%FS	
	Resistance *1	≥0.5%	
Ripple *2	Vpp	20Hz-20MHz	≤0.14%FS
	Vrms	20Hz-20MHz	≤0.028%FS
	Irms	20Hz-300KHz	≤0.14%FS
Setup Temperature Coefficient	Voltage	≤15PPM/°C	
	Current	≤30PPM/°C	
Read Back Temperature Coefficient	Voltage	≤15PPM/°C	
	Current	≤30PPM/°C	
Rise Time (no load)	Voltage	≤2ms	
Rise Time (full load)	Voltage	≤2ms	
Fall Time (no load)	Voltage	≤1s	
Fall Time (full load)	Voltage	≤200ms	
Rise Time (Full current)	Current	≤2ms	
Fall Time (Full current)	Current	≤2ms	
Transient Response Time (change from 40% to 90% of rated current)	Voltage	≤1ms	
AC Input	Input voltage *3	Three phase +PE	105 kW Max. @180-264V-Input
			210 kW Max. @342-528V-Input
	Maximum Input Current	364A(per phase)@200Vac, 3ø input	
		383A(per phase)@380Vac, 3ø input	
		304A(per phase)@480Vac, 3ø input	
	Maximum Input Apparent Power	226.9kVA	
Frequency	47Hz~63Hz		
Power Factor *4	0.99		
Setup Stability-30min	Voltage	≤0.01%+0.01%FS	
	Current	≤0.02%+0.02%FS	
Setup Stability-8h	Voltage	≤0.01%+0.01%FS	
	Current	≤0.02%+0.02%FS	
Readback Stability-30min	Voltage	≤0.01%+0.01%FS	
	Current	≤0.02%+0.02%FS	
Readback Stability-8h	Voltage	≤0.01%+0.01%FS	
	Current	≤0.02%+0.02%FS	
Efficiency	Full current and full power	~93.5%	

	Full voltage and full power	~94%
Output Capacitance	2-channel mode	292uF/CH
Remote Sense Voltage	1%FS	
Command Response Time	1ms	
Storage Temperature	-10°C~70°C	
Protective Function	OVP, OCP, OPP, UVP, UCP, OTP, Vsense protection	
Standard Interface	Standard: USB, CAN, LAN, Digital IO Optional: GPIB, Analog/RS232), fiber optic socket, EtherCAT card, Relay cards	
Isolation (output to ground)	2250V	
Working Temperature *5	0~50°C	
IP	IP20	
Safety Standard	IEC 61010	
Cooling	Air	
Dimension ( mm)	600mm(W)* 1441.41mm(H)* 840.1mm(D) (Depth 1008.1mm including protective cover)	
Weight( net)	397kg	

\*1. This accuracy specification applies to output power in the range of 10% to 100%. When the output power is low, the resistance deviation ( $\Delta R$ ) can be approximated by:  $\Delta R \approx V / (V/R_{set} - \Delta I) - R_{set}$ . where  $V$  is the external voltage,  $R_{set}$  is the set resistance value, and  $\Delta I$  is the theoretical current deviation of the IT6600.

\*2. This specification was tested under test conditions with an output voltage of  $\geq 30V$ .

\*3. Multi-master cabinet, that is, optional emergency stop module (including AC contactor) models, the standard AC input voltage only supports 380VAC  $\pm 10\%$ , such as the need for 480VAC  $\pm 10\%$  voltage need to be customized.

\*4. Power factor of 0.99 at 50% of rated power and above at nominal input.

\*5. When the unit temperature exceeds 40°C, the rated current and power decrease by 3% for every 1°C increase. When the cabinet temperature exceeds 30°C, they decrease by 2% for every 1°C increase. Both are applicable up to a maximum of 50°C.

## IT66252D-1200-1200

Parameter		IT66252D-1200-1200	
Rated value	Voltage	Series mode	0 ~ 1200V
		2-channel mode/Parallel mode	0 ~ 600V
	Current	Parallel mode	0 ~ 1200A
		2-channel mode/Series mode	0 ~ 600A
	Power	Each channel	0 ~ 126kW
		Total	0 ~ 252kW
	Resistance in series (CV priority)	2-channel mode	0 ~ 0.1Ω
		Parallel mode	0 ~ 0.05Ω
		Series mode	0 ~ 0.2Ω
	Load resistance (CC priority)	2-channel mode	0.008 ~ 7500Ω
Parallel mode		0.004 ~ 7500Ω	
Series mode		0.016 ~ 7500Ω	
Line Regulation	Voltage	$\leq 0.01\%FS$	

	Current	$\leq 0.01\%FS$	
Load Regulation	Voltage	$\leq 0.01\%FS$	
	Current	$\leq 0.02\%FS$	
Setup Resolution	Voltage	0.001V	
	Current	0.01A	
	Power	0.001kW	
	Resistance	0.001 $\Omega$	
Read Back Resolution	Voltage	0.001V	
	Current	0.01A	
	Power	0.001kW	
Setup Accuracy	Voltage	$\leq 0.02\% + 0.02\%FS$	
	Current	$\leq 0.03\% + 0.03\%FS$	
	Power	$\leq 0.05\% + 0.15\%FS$	
	Resistance *1	$\geq 0.5\%$	
Read Back Accuracy	Voltage	$\leq 0.02\% + 0.02\%FS$	
	Current	$\leq 0.03\% + 0.03\%FS$	
	Power	$\leq 0.05\% + 0.15\%FS$	
	Resistance *1	$\geq 0.5\%$	
Ripple *2	Vpp	20Hz-20MHz	$\leq 0.15\%FS$
	Vrms	20Hz-20MHz	$\leq 0.03\%FS$
	Irms	20Hz-300KHz	$\leq 0.15\%FS$
Setup Temperature Coefficient	Voltage	$\leq 15PPM/^{\circ}C$	
	Current	$\leq 30PPM/^{\circ}C$	
Read Back Temperature Coefficient	Voltage	$\leq 15PPM/^{\circ}C$	
	Current	$\leq 30PPM/^{\circ}C$	
Rise Time (no load)	Voltage	$\leq 2ms$	
Rise Time (full load)	Voltage	$\leq 2ms$	
Fall Time (no load)	Voltage	$\leq 1s$	
Fall Time (full load)	Voltage	$\leq 200ms$	
Rise Time (Full current)	Current	$\leq 2ms$	
Fall Time (Full current)	Current	$\leq 2ms$	
Transient Response Time (change from 40% to 90% of rated current)	Voltage	$\leq 1ms$	
AC Input	Input voltage *3	Three phase +PE	126 kW Max. @180-264V-Input
			252 kW Max. @342-528V-Input
	Maximum Input Current	437A(per phase)@200Vac, 3 $\phi$ input	
		460A(per phase)@380Vac, 3 $\phi$ input	
		364A(per phase)@480Vac, 3 $\phi$ input	
	Maximum Input Apparent Power	272.3kVA	
Frequency	47Hz~63Hz		
Power Factor *4	0.99		
Setup Stability-30min	Voltage	$\leq 0.01\% + 0.01\%FS$	
	Current	$\leq 0.02\% + 0.02\%FS$	
Setup Stability-8h	Voltage	$\leq 0.01\% + 0.01\%FS$	
	Current	$\leq 0.02\% + 0.02\%FS$	
Readback Stability-30min	Voltage	$\leq 0.01\% + 0.01\%FS$	
	Current	$\leq 0.02\% + 0.02\%FS$	
Readback Stability-8h	Voltage	$\leq 0.01\% + 0.01\%FS$	

	Current	≤0.02%+0.02%FS	
Efficiency	Full current and full power	~93.5%	
	Full voltage and full power	~94%	
Output Capacitance	2-channel mode	350.4uF/CH	
Remote Sense Voltage	1%FS		
Command Response Time	1ms		
Storage Temperature	-10°C~70°C		
Protective Function	OVP, OCP, OPP, UVP, UCP, OTP, Vsense protection		
Standard Interface	Standard: USB, CAN, LAN, Digital IO Optional: GPIB, Analog/RS232), fiber optic socket, EtherCAT card, Relay cards		
Isolation (output to ground)	2250V		
Working Temperature *5	0~50°C		
IP	IP20		
Safety Standard	IEC 61010		
Cooling	Air		
Dimension ( mm)	600mm(W)* 1441.41mm(H)* 840.1mm(D) (Depth 1008.1mm including protective cover)		
Weight( net)	447kg		

\*1. This accuracy specification applies to output power in the range of 10% to 100%. When the output power is low, the resistance deviation ( $\Delta R$ ) can be approximated by:  $\Delta R \approx V / (V/R_{set} - \Delta I) - R_{set}$ . where  $V$  is the external voltage,  $R_{set}$  is the set resistance value, and  $\Delta I$  is the theoretical current deviation of the IT6600.

\*2. This specification was tested under test conditions with an output voltage of  $\geq 30V$ .

\*3. Multi-master cabinet, that is, optional emergency stop module (including AC contactor) models, the standard AC input voltage only supports 380VAC  $\pm 10\%$ , such as the need for 480VAC  $\pm 10\%$  voltage need to be customized.

\*4. Power factor of 0.99 at 50% of rated power and above at nominal input.

\*5. When the unit temperature exceeds 40°C, the rated current and power decrease by 3% for every 1°C increase. When the cabinet temperature exceeds 30°C, they decrease by 2% for every 1°C increase. Both are applicable up to a maximum of 50°C.

## IT66294D-1200-1400

Parameter		IT66294D-1200-1400	
Rated value	Voltage	Series mode	0 ~ 1200V
		2-channel mode/Parallel mode	0 ~ 600V
	Current	Parallel mode	0 ~ 1400A
		2-channel mode/Series mode	0 ~ 700A
	Power	Each channel	0 ~ 147kW
		Total	0 ~ 294kW
	Resistance in series (CV priority)	2-channel mode	0 ~ 0.086Ω
		Parallel mode	0 ~ 0.043Ω
		Series mode	0 ~ 0.172Ω
	Load resistance	2-channel mode	0.007 ~ 7500Ω

	(CC priority)	Parallel mode	0.004 ~ 7500Ω
		Series mode	0.014 ~ 7500Ω
Line Regulation	Voltage	≤0.01%FS	
	Current	≤0.01%FS	
Load Regulation	Voltage	≤0.01%FS	
	Current	≤0.02%FS	
Setup Resolution	Voltage	0.001V	
	Current	0.01A	
	Power	0.001kW	
	Resistance	0.001Ω	
Read Back Resolution	Voltage	0.001V	
	Current	0.01A	
	Power	0.001kW	
Setup Accuracy	Voltage	≤0.02%+0.02%FS	
	Current	≤0.03% + 0.03%FS	
	Power	≤0.05% + 0.15%FS	
	Resistance *1	≥0.5%	
Read Back Accuracy	Voltage	≤0.02%+0.02%FS	
	Current	≤0.03% + 0.03%FS	
	Power	≤0.05% + 0.15%FS	
	Resistance *1	≥0.5%	
Ripple *2	Vpp	20Hz-20MHz	≤0.16%FS
	Vrms	20Hz-20MHz	≤0.032%FS
	Irms	20Hz-300KHz	≤0.16%FS
Setup Temperature Coefficient	Voltage	≤15PPM/°C	
	Current	≤30PPM/°C	
Read Back Temperature Coefficient	Voltage	≤15PPM/°C	
	Current	≤30PPM/°C	
Rise Time (no load)	Voltage	≤2ms	
Rise Time (full load)	Voltage	≤2ms	
Fall Time (no load)	Voltage	≤1s	
Fall Time (full load)	Voltage	≤200ms	
Rise Time (Full current)	Current	≤2ms	
Fall Time (Full current)	Current	≤2ms	
Transient Response Time (change from 40% to 90% of rated current)	Voltage	≤1ms	
AC Input	Input voltage *3	Three phase +PE	147 kW Max. @180-264V-Input
			294 kW Max. @342-528V-Input
	Maximum Input Current	510A(per phase)@200Vac, 3ø input	
		537A(per phase)@380Vac, 3ø input	
		425A(per phase)@480Vac, 3ø input	
	Maximum Input Apparent Power	317.7kVA	
Frequency	47Hz~63Hz		
Power Factor *4	0.99		
Setup Stability-30min	Voltage	≤0.01%+0.01%FS	
	Current	≤0.02%+0.02%FS	
Setup Stability-8h	Voltage	≤0.01%+0.01%FS	
	Current	≤0.02%+0.02%FS	

Readback Stability-30min	Voltage	≤0.01%+0.01%FS	
	Current	≤0.02%+0.02%FS	
Readback Stability-8h	Voltage	≤0.01%+0.01%FS	
	Current	≤0.02%+0.02%FS	
Efficiency		Full current and full power	~93.5%
		Full voltage and full power	~94%
Output Capacitance		2-channel mode	408.8uF/CH
Remote Sense Voltage		1%FS	
Command Response Time		1ms	
Storage Temperature		-10°C~70°C	
Protective Function		OVP, OCP, OPP, UVP, UCP, OTP, Vsense protection	
Standard Interface		Standard: USB, CAN, LAN, Digital IO Optional: GPIB, Analog/RS232), fiber optic socket, EtherCAT card, Relay cards	
Isolation (output to ground)		2250V	
Working Temperature *5		0~50°C	
IP		IP20	
Safety Standard		IEC 61010	
Cooling		Air	
Dimension ( mm)		600mm(W)* 1441.41mm(H)* 840.1mm(D) (Depth 1008.1mm including protective cover)	
Weight( net)		497kg	

\*1. This accuracy specification applies to output power in the range of 10% to 100%. When the output power is low, the resistance deviation ( $\Delta R$ ) can be approximated by:  $\Delta R \approx V / (V/R_{set} - \Delta I) - R_{set}$ . where  $V$  is the external voltage,  $R_{set}$  is the set resistance value, and  $\Delta I$  is the theoretical current deviation of the IT6600.

\*2. This specification was tested under test conditions with an output voltage of  $\geq 30V$ .

\*3. Multi-master cabinet, that is, optional emergency stop module (including AC contactor) models, the standard AC input voltage only supports  $380VAC \pm 10\%$ , such as the need for  $480VAC \pm 10\%$  voltage need to be customized.

\*4. Power factor of 0.99 at 50% of rated power and above at nominal input.

\*5. When the unit temperature exceeds  $40^{\circ}C$ , the rated current and power decrease by 3% for every  $1^{\circ}C$  increase. When the cabinet temperature exceeds  $30^{\circ}C$ , they decrease by 2% for every  $1^{\circ}C$  increase. Both are applicable up to a maximum of  $50^{\circ}C$ .

## IT66336D-1200-1600

Parameter		IT66336D-1200-1600	
Rated value	Voltage	Series mode	0 ~ 1200V
		2-channel mode/Parallel mode	0 ~ 600V
	Current	Parallel mode	0 ~ 1600A
		2-channel mode/Series mode	0 ~ 800A
	Power	Each channel	0 ~ 168kW
		Total	0 ~ 336kW
Resistance in	2-channel mode	0 ~ 0.075Ω	

	series (CV priority)	Parallel mode	0 ~ 0.038Ω
		Series mode	0 ~ 0.15Ω
	Load resistance (CC priority)	2-channel mode	0.006 ~ 7500Ω
		Parallel mode	0.003 ~ 7500Ω
		Series mode	0.012 ~ 7500Ω
Line Regulation	Voltage	≤0.01%FS	
	Current	≤0.01%FS	
Load Regulation	Voltage	≤0.01%FS	
	Current	≤0.02%FS	
Setup Resolution	Voltage	0.001V	
	Current	0.01A	
	Power	0.001kW	
	Resistance	0.001Ω	
Read Back Resolution	Voltage	0.001V	
	Current	0.01A	
	Power	0.001kW	
Setup Accuracy	Voltage	≤0.02%+0.02%FS	
	Current	≤0.03% + 0.03%FS	
	Power	≤0.05% + 0.15%FS	
	Resistance *1	≥0.5%	
Read Back Accuracy	Voltage	≤0.02%+0.02%FS	
	Current	≤0.03% + 0.03%FS	
	Power	≤0.05% + 0.15%FS	
	Resistance *1	≥0.5%	
Ripple *2	Vpp	20Hz-20MHz	≤0.17%FS
	Vrms	20Hz-20MHz	≤0.034%FS
	Irms	20Hz-300KHz	≤0.17%FS
Setup Temperature Coefficient	Voltage	≤15PPM/°C	
	Current	≤30PPM/°C	
Read Back Temperature Coefficient	Voltage	≤15PPM/°C	
	Current	≤30PPM/°C	
Rise Time (no load)	Voltage	≤2ms	
Rise Time (full load)	Voltage	≤2ms	
Fall Time (no load)	Voltage	≤1s	
Fall Time (full load)	Voltage	≤200ms	
Rise Time (Full current)	Current	≤2ms	
Fall Time (Full current)	Current	≤2ms	
Transient Response Time (change from 40% to 90% of rated current)	Voltage	≤1ms	
AC Input	Input voltage *3	Three phase +PE	168 kW Max. @180-264V-Input
			336 kW Max. @342-528V-Input
	Maximum Input Current	583A(per phase)@200Vac, 3ø input	
		613A(per phase)@380Vac, 3ø input	
		486A(per phase)@480Vac, 3ø input	
	Maximum Input Apparent Power	363kVA	
Frequency	47Hz~63Hz		
Power Factor *4	0.99		

Setup Stability-30min	Voltage	≤0.01%+0.01%FS	
	Current	≤0.02%+0.02%FS	
Setup Stability-8h	Voltage	≤0.01%+0.01%FS	
	Current	≤0.02%+0.02%FS	
Readback Stability-30min	Voltage	≤0.01%+0.01%FS	
	Current	≤0.02%+0.02%FS	
Readback Stability-8h	Voltage	≤0.01%+0.01%FS	
	Current	≤0.02%+0.02%FS	
Efficiency		Full current and full power	~93.5%
		Full voltage and full power	~94%
Output Capacitance		2-channel mode	467.2uF/CH
Remote Sense Voltage		1%FS	
Command Response Time		1ms	
Storage Temperature		-10°C ~ 70°C	
Protective Function		OVP, OCP, OPP, UVP, UCP, OTP, Vsense protection	
Standard Interface		Standard: USB, CAN, LAN, Digital IO Optional: GPIB, Analog/RS232), fiber optic socket, EtherCAT card, Relay cards	
Isolation (output to ground)		2250V	
Working Temperature *5		0 ~ 50°C	
IP		IP20	
Safety Standard		IEC 61010	
Cooling		Air	
Dimension ( mm)		600mm(W)* 1885.91mm(H)* 840.1mm(D) (Depth 1008.1mm including protective cover)	
Weight( net)		583kg	

\*1. This accuracy specification applies to output power in the range of 10% to 100%. When the output power is low, the resistance deviation ( $\Delta R$ ) can be approximated by:  $\Delta R \approx V / (V/R_{set} - \Delta I) - R_{set}$ . where  $V$  is the external voltage,  $R_{set}$  is the set resistance value, and  $\Delta I$  is the theoretical current deviation of the IT6600.

\*2. This specification was tested under test conditions with an output voltage of  $\geq 30V$ .

\*3. Multi-master cabinet, that is, optional emergency stop module (including AC contactor) models, the standard AC input voltage only supports  $380VAC \pm 10\%$ , such as the need for  $480VAC \pm 10\%$  voltage need to be customized.

\*4. Power factor of 0.99 at 50% of rated power and above at nominal input.

\*5. When the unit temperature exceeds  $40^{\circ}C$ , the rated current and power decrease by 3% for every  $1^{\circ}C$  increase. When the cabinet temperature exceeds  $30^{\circ}C$ , they decrease by 2% for every  $1^{\circ}C$  increase. Both are applicable up to a maximum of  $50^{\circ}C$ .

## IT66378D-1200-1800

Parameter		IT66378D-1200-1800	
Rated value	Voltage	Series mode	0 ~ 1200V
		2-channel mode/Parallel mode	0 ~ 600V
	Current	Parallel mode	0 ~ 1800A
		2-channel mode/Series mode	0 ~ 900A

	Power	Each channel	0 ~ 189kW
		Total	0 ~ 378kW
	Resistance in series (CV priority)	2-channel mode	0 ~ 0.067Ω
		Parallel mode	0 ~ 0.034Ω
		Series mode	0 ~ 0.134Ω
	Load resistance (CC priority)	2-channel mode	0.006 ~ 7500Ω
Parallel mode		0.003 ~ 7500Ω	
Series mode		0.011 ~ 7500Ω	
Line Regulation	Voltage	≤0.01%FS	
	Current	≤0.01%FS	
Load Regulation	Voltage	≤0.01%FS	
	Current	≤0.02%FS	
Setup Resolution	Voltage	0.001V	
	Current	0.01A	
	Power	0.001kW	
	Resistance	0.001Ω	
Read Back Resolution	Voltage	0.001V	
	Current	0.01A	
	Power	0.001kW	
Setup Accuracy	Voltage	≤0.02%+0.02%FS	
	Current	≤0.03% + 0.03%FS	
	Power	≤0.05% + 0.15%FS	
	Resistance *1	≥0.5%	
Read Back Accuracy	Voltage	≤0.02%+0.02%FS	
	Current	≤0.03% + 0.03%FS	
	Power	≤0.05% + 0.15%FS	
	Resistance *1	≥0.5%	
Ripple *2	V <sub>pp</sub>	20Hz-20MHz	≤0.18%FS
	V <sub>rms</sub>	20Hz-20MHz	≤0.036%FS
	I <sub>rms</sub>	20Hz-300KHz	≤0.18%FS
Setup Temperature Coefficient	Voltage	≤15PPM/°C	
	Current	≤30PPM/°C	
Read Back Temperature Coefficient	Voltage	≤15PPM/°C	
	Current	≤30PPM/°C	
Rise Time (no load)	Voltage	≤2ms	
Rise Time (full load)	Voltage	≤2ms	
Fall Time (no load)	Voltage	≤1s	
Fall Time (full load)	Voltage	≤200ms	
Rise Time (Full current)	Current	≤2ms	
Fall Time (Full current)	Current	≤2ms	
Transient Response Time (change from 40% to 90% of rated current)	Voltage	≤1ms	
AC Input	Input voltage *3	Three phase +PE	189 kW Max. @180-264V-Input
			378 kW Max. @342-528V-Input
	Maximum Input Current	655A(per phase)@200Vac, 3ø input	
		690A(per phase)@380Vac, 3ø input	
546A(per phase)@480Vac, 3ø input			

	Maximum Input Apparent Power	408.4kVA	
	Frequency	47Hz~63Hz	
	Power Factor *4	0.99	
Setup Stability-30min	Voltage	$\leq 0.01\% + 0.01\%FS$	
	Current	$\leq 0.02\% + 0.02\%FS$	
Setup Stability-8h	Voltage	$\leq 0.01\% + 0.01\%FS$	
	Current	$\leq 0.02\% + 0.02\%FS$	
Readback Stability-30min	Voltage	$\leq 0.01\% + 0.01\%FS$	
	Current	$\leq 0.02\% + 0.02\%FS$	
Readback Stability-8h	Voltage	$\leq 0.01\% + 0.01\%FS$	
	Current	$\leq 0.02\% + 0.02\%FS$	
Efficiency	Full current and full power	~93.5%	
	Full voltage and full power	~94%	
Output Capacitance	2-channel mode	525.6uF/CH	
Remote Sense Voltage	1%FS		
Command Response Time	1ms		
Storage Temperature	$-10^{\circ}C \sim 70^{\circ}C$		
Protective Function	OVP, OCP, OPP, UVP, UCP, OTP, Vsense protection		
Standard Interface	Standard: USB, CAN, LAN, Digital IO Optional: GPIB, Analog/RS232), fiber optic socket, EtherCAT card, Relay cards		
Isolation (output to ground)	2250V		
Working Temperature *5	$0 \sim 50^{\circ}C$		
IP	IP20		
Safety Standard	IEC 61010		
Cooling	Air		
Dimension ( mm)	600mm(W)* 1885.91mm(H)* 840.1mm(D) (Depth 1008.1mm including protective cover)		
Weight( net)	633kg		

\*1. This accuracy specification applies to output power in the range of 10% to 100%. When the output power is low, the resistance deviation ( $\Delta R$ ) can be approximated by:  $\Delta R \approx V / (V/R_{set} - \Delta I) - R_{set}$ . where V is the external voltage,  $R_{set}$  is the set resistance value, and  $\Delta I$  is the theoretical current deviation of the IT6600.

\*2. This specification was tested under test conditions with an output voltage of  $\geq 30V$ .

\*3. Multi-master cabinet, that is, optional emergency stop module (including AC contactor) models, the standard AC input voltage only supports  $380VAC \pm 10\%$ , such as the need for  $480VAC \pm 10\%$  voltage need to be customized.

\*4. Power factor of 0.99 at 50% of rated power and above at nominal input.

\*5. When the unit temperature exceeds  $40^{\circ}C$ , the rated current and power decrease by 3% for every  $1^{\circ}C$  increase. When the cabinet temperature exceeds  $30^{\circ}C$ , they decrease by 2% for every  $1^{\circ}C$  increase. Both are applicable up to a maximum of  $50^{\circ}C$ .

**IT66420D-1200-2000**

Parameter		IT66420D-1200-2000	
Rated value	Voltage	Series mode	0 ~ 1200V
		2-channel mode/Parallel mode	0 ~ 600V
	Current	Parallel mode	0 ~ 2000A
		2-channel mode/Series mode	0 ~ 1000A
	Power	Each channel	0 ~ 210kW
		Total	0 ~ 420kW
	Resistance in series (CV priority)	2-channel mode	0 ~ 0.06Ω
		Parallel mode	0 ~ 0.03Ω
		Series mode	0 ~ 0.12Ω
	Load resistance (CC priority)	2-channel mode	0.005 ~ 7500Ω
Parallel mode		0.003 ~ 7500Ω	
Series mode		0.01 ~ 7500Ω	
Line Regulation	Voltage	≤0.01%FS	
	Current	≤0.01%FS	
Load Regulation	Voltage	≤0.01%FS	
	Current	≤0.02%FS	
Setup Resolution	Voltage	0.001V	
	Current	0.01A	
	Power	0.001kW	
	Resistance	0.001Ω	
Read Back Resolution	Voltage	0.001V	
	Current	0.01A	
	Power	0.001kW	
Setup Accuracy	Voltage	≤0.02%+0.02%FS	
	Current	≤0.03% + 0.03%FS	
	Power	≤0.05% + 0.15%FS	
	Resistance *1	≥0.5%	
Read Back Accuracy	Voltage	≤0.02%+0.02%FS	
	Current	≤0.03% + 0.03%FS	
	Power	≤0.05% + 0.15%FS	
	Resistance *1	≥0.5%	
Ripple *2	Vpp	20Hz-20MHz	≤0.19%FS
	Vrms	20Hz-20MHz	≤0.038%FS
	Irms	20Hz-300KHz	≤0.19%FS
Setup Temperature Coefficient	Voltage	≤15PPM/°C	
	Current	≤30PPM/°C	
Read Back Temperature Coefficient	Voltage	≤15PPM/°C	
	Current	≤30PPM/°C	
Rise Time (no load)	Voltage	≤2ms	
Rise Time (full load)	Voltage	≤2ms	
Fall Time (no load)	Voltage	≤1s	
Fall Time (full load)	Voltage	≤200ms	
Rise Time (Full current)	Current	≤2ms	
Fall Time (Full current)	Current	≤2ms	

Transient Response Time (change from 40% to 90% of rated current)	Voltage	≤1ms	
AC Input	Input voltage *3	Three phase +PE	210 kW Max. @180-264V-Input
			420 kW Max. @342-528V-Input
	Maximum Input Current	728A(per phase)@200Vac, 3ø input	
		766A(per phase)@380Vac, 3ø input	
		607A(per phase)@480Vac, 3ø input	
	Maximum Input Apparent Power	453.8kVA	
Frequency	47Hz~63Hz		
Power Factor *4	0.99		
Setup Stability-30min	Voltage	≤0.01%+0.01%FS	
	Current	≤0.02%+0.02%FS	
Setup Stability-8h	Voltage	≤0.01%+0.01%FS	
	Current	≤0.02%+0.02%FS	
Readback Stability-30min	Voltage	≤0.01%+0.01%FS	
	Current	≤0.02%+0.02%FS	
Readback Stability-8h	Voltage	≤0.01%+0.01%FS	
	Current	≤0.02%+0.02%FS	
Efficiency	Full current and full power	~93.5%	
	Full voltage and full power	~94%	
Output Capacitance	2-channel mode	584uF/CH	
Remote Sense Voltage	1%FS		
Command Response Time	1ms		
Storage Temperature	-10°C~70°C		
Protective Function	OVP, OCP, OPP, UVP, UCP, OTP, Vsense protection		
Standard Interface	Standard: USB, CAN, LAN, Digital IO Optional: GPIB, Analog/RS232), fiber optic socket, EtherCAT card, Relay cards		
Isolation (output to ground)	2250V		
Working Temperature *5	0~50°C		
IP	IP20		
Safety Standard	IEC 61010		
Cooling	Air		
Dimension ( mm)	600mm(W)* 1885.91mm(H)* 840.1mm(D) (Depth 1008.1mm including protective cover)		
Weight( net)	683kg		

\*1. This accuracy specification applies to output power in the range of 10% to 100%. When the output power is low, the resistance deviation ( $\Delta R$ ) can be approximated by:  $\Delta R \approx V / (V/R_{set} - \Delta I) - R_{set}$ . where  $V$  is the external voltage,  $R_{set}$  is the set resistance value, and  $\Delta I$  is the theoretical current deviation of the IT6600.

\*2. This specification was tested under test conditions with an output voltage of  $\geq 30V$ .

\*3. Multi-master cabinet, that is, optional emergency stop module (including AC contactor) models, the standard AC input voltage only supports 380VAC  $\pm 10\%$ , such as the need for 480VAC  $\pm 10\%$  voltage need to be customized.

\*4. Power factor of 0.99 at 50% of rated power and above at nominal input.

\*5. When the unit temperature exceeds 40°C, the rated current and power decrease by 3% for

every 1°C increase. When the cabinet temperature exceeds 30°C, they decrease by 2% for every 1°C increase. Both are applicable up to a maximum of 50°C.

## IT6642D-1600-140

Parameter		IT6642D-1600-140	
Rated value	Voltage	Series mode	0~1600V
		2-channel mode/Parallel mode	0~800V
	Current	Parallel mode	0~140A
		2-channel mode/Series mode	0~70A
	Power	Each channel	0~21kW
		Total	0~42kW
	Resistance in series (CV priority)	2-channel mode	0~1.143Ω
		Parallel mode	0~0.572Ω
		Series mode	0~2.286Ω
	Load resistance (CC priority)	2-channel mode	0.066~7500Ω
Parallel mode		0.033~7500Ω	
Series mode		0.131~7500Ω	
Line Regulation	Voltage	≤0.005%FS	
	Current	≤0.005%FS	
Load Regulation	Voltage	≤0.005%FS	
	Current	≤0.015%FS	
Setup Resolution	Voltage	0.001V	
	Current	0.001A	
	Power	0.001kW	
	Resistance	0.001Ω	
Read Back Resolution	Voltage	0.001V	
	Current	0.001A	
	Power	0.001kW	
Setup Accuracy	Voltage	≤0.02%+0.01%FS	
	Current	≤0.03% + 0.03%FS	
	Power	≤0.05% + 0.15%FS	
	Resistance *1	≤0.5%	
Read Back Accuracy	Voltage	≤0.02%+0.01%FS	
	Current	≤0.03% + 0.03%FS	
	Power	≤0.05% + 0.15%FS	
	Resistance *1	≤0.5%	
Ripple *2	Vpp	20Hz-20MHz	≤0.1%FS
	Vrms	20Hz-20MHz	≤0.02%FS
	Irms	20Hz-300KHz	≤0.1%FS
Setup Temperature Coefficient	Voltage	≤15PPM/°C	
	Current	≤30PPM/°C	
Read Back Temperature Coefficient	Voltage	≤15PPM/°C	
	Current	≤30PPM/°C	
Rise Time( no load )	Voltage	≤1ms	
Rise Time( full load )	Voltage	≤1ms	

Fall Time( no load )	Voltage	$\leq 1s$	
Fall Time( full load )	Voltage	$\leq 100ms$	
Rise Time( full current )	Current	$\leq 1ms$	
Fall Time( full current )	Current	$\leq 1ms$	
Transient Response Time(change from 40% to 90% of rated current)	Voltage	$\leq 200us$	
AC Input	Input voltage *3	Three phase + PE	21 kW Max. @180-264V-Input
			42 kW Max. @342-528V-Input
	Maximum Input Current	73A(per phase)@200Vac, 3 $\phi$ input	
		77A(per phase)@380Vac, 3 $\phi$ input	
		61A(per phase)@480Vac, 3 $\phi$ input	
	Maximum Input Apparent Power	45.4kVA	
Frequency	47Hz~63Hz		
Power Factor *4	0.99		
Setup Stability-30min	Voltage	$\leq 0.005\%+0.005\%FS$	
	Current	$\leq 0.01\%+0.01\%FS$	
Setup Stability-8h	Voltage	$\leq 0.005\%+0.005\%FS$	
	Current	$\leq 0.01\%+0.01\%FS$	
Readback Stability-30min	Voltage	$\leq 0.005\%+0.005\%FS$	
	Current	$\leq 0.01\%+0.01\%FS$	
Readback Stability-8h	Voltage	$\leq 0.005\%+0.005\%FS$	
	Current	$\leq 0.01\%+0.01\%FS$	
Efficiency	Full current and full power	$\sim 93.5\%$	
	Full voltage and full power	$\sim 94\%$	
Output Port Capacitance	2-channel mode	14.6uF/CH	
Remote Sense Voltage	1%FS		
Command Response Time	1ms		
Storage Temperature	$-10^{\circ}C \sim 70^{\circ}C$		
Protective Function	OVP, OCP, OPP, UVP, UCP, OTP, Vsense protection		
Standard Interface	Standard: USB, CAN, LAN, Digital IO Optional: GPIB, Analog/RS232), fiber optic socket, EtherCAT card, Relay cards		
Isolation (output to ground)	2250V		
Working Temperature *5	$0 \sim 50^{\circ}C$		
IP	IP20		
Safety Standard	IEC 61010		
Cooling	Air		
Dimension (mm)	483mm(W)* 151.3mm(H)* 831.6mm(D)		
Weight( net)	50kg		

\*1. This accuracy specification applies to output power in the range of 10% to 100%. When the output power is low, the resistance deviation ( $\Delta R$ ) can be approximated by:  $\Delta R \approx V / (V/R_{set} - \Delta I) - R_{set}$ . where V is the external voltage, Rset is the set resistance value, and  $\Delta I$  is the theoretical current deviation of the IT6600.

\*2. This specification was tested under test conditions with an output voltage of  $\geq 30V$ .

\*3. Multi-master cabinet, that is, optional emergency stop module (including AC contactor) models, the standard AC input voltage only supports 380VAC  $\pm 10\%$ , such as the need for 480VAC  $\pm 10\%$

voltage need to be customized.

\*4. Power factor of 0.99 at 50% of rated power and above at nominal input.

\*5. When the unit temperature exceeds 40°C, the rated current and power decrease by 3% for every 1°C increase. When the cabinet temperature exceeds 30°C, they decrease by 2% for every 1°C increase. Both are applicable up to a maximum of 50°C.

## IT6684D-1600-280

Parameter		IT6684D-1600-280	
Rated value	Voltage	Series mode	0 ~ 1600V
		2-channel mode/Parallel mode	0 ~ 800V
	Current	Parallel mode	0 ~ 280A
		2-channel mode/Series mode	0 ~ 140A
	Power	Each channel	0 ~ 42kW
		Total	0 ~ 84kW
	Resistance in series (CV priority)	2-channel mode	0 ~ 0.572Ω
		Parallel mode	0 ~ 0.286Ω
		Series mode	0 ~ 1.143Ω
	Load resistance (CC priority)	2-channel mode	0.033 ~ 7500Ω
Parallel mode		0.017 ~ 7500Ω	
Series mode		0.066 ~ 7500Ω	
Line Regulation	Voltage	≤0.005%FS	
	Current	≤0.005%FS	
Load Regulation	Voltage	≤0.005%FS	
	Current	≤0.015%FS	
Setup Resolution	Voltage	0.001V	
	Current	0.001A	
	Power	0.001kW	
	Resistance	0.001Ω	
Read Back Resolution	Voltage	0.001V	
	Current	0.001A	
	Power	0.001kW	
Setup Accuracy	Voltage	≤0.02%+0.01%FS	
	Current	≤0.03% + 0.03%FS	
	Power	≤0.05% + 0.15%FS	
	Resistance *1	≥0.5%	
Read Back Accuracy	Voltage	≤0.02%+0.01%FS	
	Current	≤0.03% + 0.03%FS	
	Power	≤0.05% + 0.15%FS	
	Resistance *1	≥0.5%	
Ripple *2	Vpp	20Hz-20MHz	≤0.11%FS
	Vrms	20Hz-20MHz	≤0.022%FS
	Irms	20Hz-300KHz	≤0.11%FS
Setup Temperature Coefficient	Voltage	≤15PPM/°C	
	Current	≤30PPM/°C	
Read Back Temperature Coefficient	Voltage	≤15PPM/°C	
	Current	≤30PPM/°C	

Rise Time (no load)	Voltage	≤1ms	
Rise Time (full load)	Voltage	≤1ms	
Fall Time (no load)	Voltage	≤1s	
Fall Time (full load)	Voltage	≤100ms	
Rise Time (Full current)	Current	≤1ms	
Fall Time (Full current)	Current	≤1ms	
Transient Response Time (change from 40% to 90% of rated current)	Voltage	≤200us	
AC Input	Input voltage *3	Three phase +PE	42 kW Max. @180-264V-Input
			84 kW Max. @342-528V-Input
	Maximum Input Current	146A(per phase)@200Vac, 3ø input	
		154A(per phase)@380Vac, 3ø input	
		122A(per phase)@480Vac, 3ø input	
	Maximum Input Apparent Power	90.8kVA	
Frequency	47Hz~63Hz		
Power Factor *4	0.99		
Setup Stability-30min	Voltage	≤0.005%+0.005%FS	
	Current	≤0.01%+0.01%FS	
Setup Stability-8h	Voltage	≤0.005%+0.005%FS	
	Current	≤0.01%+0.01%FS	
Readback Stability-30min	Voltage	≤0.005%+0.005%FS	
	Current	≤0.01%+0.01%FS	
Readback Stability-8h	Voltage	≤0.005%+0.005%FS	
	Current	≤0.01%+0.01%FS	
Efficiency	Full current and full power	~93.5%	
	Full voltage and full power	~94%	
Output Capacitance	2-channel mode	29.2uF/CH	
Remote Sense Voltage	1%FS		
Command Response Time	1ms		
Storage Temperature	-10°C~70°C		
Protective Function	OVP, OCP, OPP, UVP, UCP, OTP, Vsense protection		
Standard Interface	Standard: USB, CAN, LAN, Digital IO Optional: GPIB, Analog/RS232), fiber optic socket, EtherCAT card, Relay cards		
Isolation (output to ground)	2250V		
Working Temperature *5	0~50°C		
IP	IP20		
Safety Standard	IEC 61010		
Cooling	Air		
NET Dimension ( mm)	500mm(W)* 907.64mm(H)* 841.1mm(D) (Depth 1008.1mm including protective cover)		
Weight( net)	186kg		

\*1. This accuracy specification applies to output power in the range of 10% to 100%. When the output power is low, the resistance deviation ( $\Delta R$ ) can be approximated by:  $\Delta R \approx V / (V/R_{set} - \Delta I) - R_{set}$ . where V is the external voltage, Rset is the set resistance value, and  $\Delta I$  is the theoretical current deviation of the IT6600.

- \*2. This specification was tested under test conditions with an output voltage of  $\geq 30V$ .
- \*3. Multi-master cabinet, that is, optional emergency stop module (including AC contactor) models, the standard AC input voltage only supports  $380VAC \pm 10\%$ , such as the need for  $480VAC \pm 10\%$  voltage need to be customized.
- \*4. Power factor of 0.99 at 50% of rated power and above at nominal input.
- \*5. When the unit temperature exceeds  $40^{\circ}C$ , the rated current and power decrease by 3% for every  $1^{\circ}C$  increase. When the cabinet temperature exceeds  $30^{\circ}C$ , they decrease by 2% for every  $1^{\circ}C$  increase. Both are applicable up to a maximum of  $50^{\circ}C$ .

## IT66126D-1600-420

Parameter		IT66126D-1600-420	
Rated value	Voltage	Series mode	0 ~ 1600V
		2-channel mode/Parallel mode	0 ~ 800V
	Current	Parallel mode	0 ~ 420A
		2-channel mode/Series mode	0 ~ 210A
	Power	Each channel	0 ~ 63kW
		Total	0 ~ 126kW
	Resistance in series (CV priority)	2-channel mode	0 ~ 0.381 $\Omega$
		Parallel mode	0 ~ 0.191 $\Omega$
		Series mode	0 ~ 0.762 $\Omega$
	Load resistance (CC priority)	2-channel mode	0.022 ~ 7500 $\Omega$
Parallel mode		0.011 ~ 7500 $\Omega$	
Series mode		0.044 ~ 7500 $\Omega$	
Line Regulation	Voltage	$\leq 0.005\%FS$	
	Current	$\leq 0.005\%FS$	
Load Regulation	Voltage	$\leq 0.005\%FS$	
	Current	$\leq 0.015\%FS$	
Setup Resolution	Voltage	0.001V	
	Current	0.001A	
	Power	0.001kW	
	Resistance	0.001 $\Omega$	
Read Back Resolution	Voltage	0.001V	
	Current	0.001A	
	Power	0.001kW	
Setup Accuracy	Voltage	$\leq 0.02\% + 0.01\%FS$	
	Current	$\leq 0.03\% + 0.03\%FS$	
	Power	$\leq 0.05\% + 0.15\%FS$	
	Resistance *1	$\geq 0.5\%$	
Read Back Accuracy	Voltage	$\leq 0.02\% + 0.01\%FS$	
	Current	$\leq 0.03\% + 0.03\%FS$	
	Power	$\leq 0.05\% + 0.15\%FS$	
	Resistance *1	$\geq 0.5\%$	
Ripple *2	Vpp	20Hz-20MHz	$\leq 0.12\%FS$
	Vrms	20Hz-20MHz	$\leq 0.024\%FS$
	Irms	20Hz-300KHz	$\leq 0.12\%FS$
Setup Temperature	Voltage	$\leq 15PPM/^{\circ}C$	

Coefficient	Current	$\leq 30\text{PPM}/^{\circ}\text{C}$	
Read Back Temperature Coefficient	Voltage	$\leq 15\text{PPM}/^{\circ}\text{C}$	
	Current	$\leq 30\text{PPM}/^{\circ}\text{C}$	
Rise Time (no load)	Voltage	$\leq 1\text{ms}$	
Rise Time (full load)	Voltage	$\leq 1\text{ms}$	
Fall Time (no load)	Voltage	$\leq 1\text{s}$	
Fall Time (full load)	Voltage	$\leq 100\text{ms}$	
Rise Time (Full current)	Current	$\leq 1\text{ms}$	
Fall Time (Full current)	Current	$\leq 1\text{ms}$	
Transient Response Time (change from 40% to 90% of rated current)	Voltage	$\leq 200\mu\text{s}$	
AC Input	Input voltage *3	Three phase +PE	63 kW Max. @180-264V-Input
			126 kW Max. @342-528V-Input
	Maximum Input Current	219A(per phase)@200Vac, 3 $\phi$ input	
		230A(per phase)@380Vac, 3 $\phi$ input	
		182A(per phase)@480Vac, 3 $\phi$ input	
	Maximum Input Apparent Power	136.2kVA	
Frequency	47Hz~63Hz		
Power Factor *4	0.99		
Setup Stability-30min	Voltage	$\leq 0.005\%+0.005\%\text{FS}$	
	Current	$\leq 0.01\%+0.01\%\text{FS}$	
Setup Stability-8h	Voltage	$\leq 0.005\%+0.005\%\text{FS}$	
	Current	$\leq 0.01\%+0.01\%\text{FS}$	
Readback Stability-30min	Voltage	$\leq 0.005\%+0.005\%\text{FS}$	
	Current	$\leq 0.01\%+0.01\%\text{FS}$	
Readback Stability-8h	Voltage	$\leq 0.005\%+0.005\%\text{FS}$	
	Current	$\leq 0.01\%+0.01\%\text{FS}$	
Efficiency	Full current and full power	$\sim 93.5\%$	
	Full voltage and full power	$\sim 94\%$	
Output Capacitance	2-channel mode	43.8 $\mu\text{F}/\text{CH}$	
Remote Sense Voltage	1%FS		
Command Response Time	1ms		
Storage Temperature	$-10^{\circ}\text{C}\sim 70^{\circ}\text{C}$		
Protective Function	OVP, OCP, OPP, UVP, UCP, OTP, Vsense protection		
Standard Interface	Standard: USB, CAN, LAN, Digital IO Optional: GPIB, Analog/RS232), fiber optic socket, EtherCAT card, Relay cards		
Isolation (output to ground)	2250V		
Working Temperature *5	$0\sim 50^{\circ}\text{C}$		
IP	IP20		
Safety Standard	IEC 61010		
Cooling	Air		
NET Dimension ( mm)	500mm(W)* 907.64mm(H)* 841.1mm(D) (Depth 1008.1mm including protective cover)		
Weight( net)	237kg		

\*1. This accuracy specification applies to output power in the range of 10% to 100%. When the output power is low, the resistance deviation ( $\Delta R$ ) can be approximated by:  $\Delta R \approx V / (V/R_{set} - \Delta I) - R_{set}$ . where  $V$  is the external voltage,  $R_{set}$  is the set resistance value, and  $\Delta I$  is the theoretical current deviation of the IT6600.

\*2. This specification was tested under test conditions with an output voltage of  $\geq 30V$ .

\*3. Multi-master cabinet, that is, optional emergency stop module (including AC contactor) models, the standard AC input voltage only supports 380VAC  $\pm 10\%$ , such as the need for 480VAC  $\pm 10\%$  voltage need to be customized.

\*4. Power factor of 0.99 at 50% of rated power and above at nominal input.

\*5. When the unit temperature exceeds 40°C, the rated current and power decrease by 3% for every 1°C increase. When the cabinet temperature exceeds 30°C, they decrease by 2% for every 1°C increase. Both are applicable up to a maximum of 50°C.

## IT66168D-1600-560

Parameter		IT66168D-1600-560	
Rated value	Voltage	Series mode	0 ~ 1600V
		2-channel mode/Parallel mode	0 ~ 800V
	Current	Parallel mode	0 ~ 560A
		2-channel mode/Series mode	0 ~ 280A
	Power	Each channel	0 ~ 84kW
		Total	0 ~ 168kW
	Resistance in series (CV priority)	2-channel mode	0 ~ 0.286 $\Omega$
		Parallel mode	0 ~ 0.143 $\Omega$
		Series mode	0 ~ 0.572 $\Omega$
	Load resistance (CC priority)	2-channel mode	0.017 ~ 7500 $\Omega$
Parallel mode		0.009 ~ 7500 $\Omega$	
Series mode		0.033 ~ 7500 $\Omega$	
Line Regulation	Voltage	$\leq 0.005\%FS$	
	Current	$\leq 0.005\%FS$	
Load Regulation	Voltage	$\leq 0.005\%FS$	
	Current	$\leq 0.015\%FS$	
Setup Resolution	Voltage	0.001V	
	Current	0.001A	
	Power	0.001kW	
	Resistance	0.001 $\Omega$	
Read Back Resolution	Voltage	0.001V	
	Current	0.001A	
	Power	0.001kW	
Setup Accuracy	Voltage	$\leq 0.02\% + 0.01\%FS$	
	Current	$\leq 0.03\% + 0.03\%FS$	
	Power	$\leq 0.05\% + 0.15\%FS$	
	Resistance *1	$\geq 0.5\%$	
Read Back Accuracy	Voltage	$\leq 0.02\% + 0.01\%FS$	
	Current	$\leq 0.03\% + 0.03\%FS$	
	Power	$\leq 0.05\% + 0.15\%FS$	
	Resistance *1	$\geq 0.5\%$	

Ripple *2	Vpp	20Hz-20MHz	≤0.13%FS
	Vrms	20Hz-20MHz	≤0.026%FS
	Irms	20Hz-300KHz	≤0.13%FS
Setup Temperature Coefficient	Voltage	≤15PPM/°C	
	Current	≤30PPM/°C	
Read Back Temperature Coefficient	Voltage	≤15PPM/°C	
	Current	≤30PPM/°C	
Rise Time (no load)	Voltage	≤1ms	
Rise Time (full load)	Voltage	≤1ms	
Fall Time (no load)	Voltage	≤1s	
Fall Time (full load)	Voltage	≤100ms	
Rise Time (Full current)	Current	≤1ms	
Fall Time (Full current)	Current	≤1ms	
Transient Response Time (change from 40% to 90% of rated current)	Voltage	≤200us	
AC Input	Input voltage *3	Three phase +PE	84 kW Max. @180-264V-Input
			168 kW Max. @342-528V-Input
	Maximum Input Current	292A(per phase)@200Vac, 3ø input	
		307A(per phase)@380Vac, 3ø input	
		243A(per phase)@480Vac, 3ø input	
	Maximum Input Apparent Power	181.5kVA	
Frequency	47Hz~63Hz		
Power Factor *4	0.99		
Setup Stability-30min	Voltage	≤0.005%+0.005%FS	
	Current	≤0.01%+0.01%FS	
Setup Stability-8h	Voltage	≤0.005%+0.005%FS	
	Current	≤0.01%+0.01%FS	
Readback Stability-30min	Voltage	≤0.005%+0.005%FS	
	Current	≤0.01%+0.01%FS	
Readback Stability-8h	Voltage	≤0.005%+0.005%FS	
	Current	≤0.01%+0.01%FS	
Efficiency	Full current and full power	~93.5%	
	Full voltage and full power	~94%	
Output Capacitance	2-channel mode	58.4uF/CH	
Remote Sense Voltage	1%FS		
Command Response Time	1ms		
Storage Temperature	-10°C~70°C		
Protective Function	OVP, OCP, OPP, UVP, UCP, OTP, Vsense protection		
Standard Interface	Standard: USB, CAN, LAN, Digital IO Optional: GPIB, Analog/RS232), fiber optic socket, EtherCAT card, Relay cards		
Isolation (output to ground)	2250V		
Working Temperature *5	0~50°C		
IP	IP20		
Safety Standard	IEC 61010		
Cooling	Air		
Dimension ( mm)	600mm(W)* 1441.41mm(H)* 840.1mm(D) (Depth 1008.1mm including protective cover)		

Weight( net)	346kg
--------------	-------

\*1. This accuracy specification applies to output power in the range of 10% to 100%. When the output power is low, the resistance deviation ( $\Delta R$ ) can be approximated by:  $\Delta R \approx V / (V/R_{set} - \Delta I) - R_{set}$ . where  $V$  is the external voltage,  $R_{set}$  is the set resistance value, and  $\Delta I$  is the theoretical current deviation of the IT6600.

\*2. This specification was tested under test conditions with an output voltage of  $\geq 30V$ .

\*3. Multi-master cabinet, that is, optional emergency stop module (including AC contactor) models, the standard AC input voltage only supports  $380VAC \pm 10\%$ , such as the need for  $480VAC \pm 10\%$  voltage need to be customized.

\*4. Power factor of 0.99 at 50% of rated power and above at nominal input.

\*5. When the unit temperature exceeds  $40^{\circ}C$ , the rated current and power decrease by 3% for every  $1^{\circ}C$  increase. When the cabinet temperature exceeds  $30^{\circ}C$ , they decrease by 2% for every  $1^{\circ}C$  increase. Both are applicable up to a maximum of  $50^{\circ}C$ .

## IT66210D-1600-700

Parameter		IT66210D-1600-700	
Rated value	Voltage	Series mode	0 ~ 1600V
		2-channel mode/Parallel mode	0 ~ 800V
	Current	Parallel mode	0 ~ 700A
		2-channel mode/Series mode	0 ~ 350A
	Power	Each channel	0 ~ 105kW
		Total	0 ~ 210kW
	Resistance in series (CV priority)	2-channel mode	0 ~ 0.229 $\Omega$
		Parallel mode	0 ~ 0.115 $\Omega$
		Series mode	0 ~ 0.458 $\Omega$
	Load resistance (CC priority)	2-channel mode	0.014 ~ 7500 $\Omega$
Parallel mode		0.007 ~ 7500 $\Omega$	
Series mode		0.027 ~ 7500 $\Omega$	
Line Regulation	Voltage	$\leq 0.01\%FS$	
	Current	$\leq 0.01\%FS$	
Load Regulation	Voltage	$\leq 0.01\%FS$	
	Current	$\leq 0.02\%FS$	
Setup Resolution	Voltage	0.001V	
	Current	0.01A	
	Power	0.001kW	
	Resistance	0.001 $\Omega$	
Read Back Resolution	Voltage	0.001V	
	Current	0.01A	
	Power	0.001kW	
Setup Accuracy	Voltage	$\leq 0.02\% + 0.02\%FS$	
	Current	$\leq 0.03\% + 0.03\%FS$	
	Power	$\leq 0.05\% + 0.15\%FS$	
	Resistance *1	$\geq 0.5\%$	
Read Back Accuracy	Voltage	$\leq 0.02\% + 0.02\%FS$	
	Current	$\leq 0.03\% + 0.03\%FS$	
	Power	$\leq 0.05\% + 0.15\%FS$	

	Resistance *1	≥0.5%	
Ripple *2	Vpp	20Hz-20MHz	≤0.14%FS
	Vrms	20Hz-20MHz	≤0.028%FS
	Irms	20Hz-300KHz	≤0.14%FS
Setup Temperature Coefficient	Voltage	≤15PPM/°C	
	Current	≤30PPM/°C	
Read Back Temperature Coefficient	Voltage	≤15PPM/°C	
	Current	≤30PPM/°C	
Rise Time (no load)	Voltage	≤2ms	
Rise Time (full load)	Voltage	≤2ms	
Fall Time (no load)	Voltage	≤1s	
Fall Time (full load)	Voltage	≤200ms	
Rise Time (Full current)	Current	≤2ms	
Fall Time (Full current)	Current	≤2ms	
Transient Response Time (change from 40% to 90% of rated current)	Voltage	≤1ms	
AC Input	Input voltage *3	Three phase +PE	105 kW Max. @180-264V-Input
			210 kW Max. @342-528V-Input
	Maximum Input Current	364A(per phase)@200Vac, 3ø input	
		383A(per phase)@380Vac, 3ø input	
		304A(per phase)@480Vac, 3ø input	
	Maximum Input Apparent Power	226.9kVA	
Frequency	47Hz~63Hz		
Power Factor *4	0.99		
Setup Stability-30min	Voltage	≤0.01%+0.01%FS	
	Current	≤0.02%+0.02%FS	
Setup Stability-8h	Voltage	≤0.01%+0.01%FS	
	Current	≤0.02%+0.02%FS	
Readback Stability-30min	Voltage	≤0.01%+0.01%FS	
	Current	≤0.02%+0.02%FS	
Readback Stability-8h	Voltage	≤0.01%+0.01%FS	
	Current	≤0.02%+0.02%FS	
Efficiency	Full current and full power	~93.5%	
	Full voltage and full power	~94%	
Output Capacitance	2-channel mode	73uF/CH	
Remote Sense Voltage	1%FS		
Command Response Time	1ms		
Storage Temperature	-10°C~70°C		
Protective Function	OVP, OCP, OPP, UVP, UCP, OTP, Vsense protection		
Standard Interface	Standard: USB, CAN, LAN, Digital IO Optional: GPIB, Analog/RS232), fiber optic socket, EtherCAT card, Relay cards		
Isolation (output to ground)	2250V		
Working Temperature *5	0~50°C		
IP	IP20		
Safety Standard	IEC 61010		
Cooling	Air		

NET Dimension ( mm)	600mm(W)* 1441.41mm(H)* 840.1mm(D) (Depth 1008.1mm including protective cover)
Weight( net)	397kg

\*1. This accuracy specification applies to output power in the range of 10% to 100%. When the output power is low, the resistance deviation ( $\Delta R$ ) can be approximated by:  $\Delta R \approx V / (V/R_{set} - \Delta I) - R_{set}$ . where  $V$  is the external voltage,  $R_{set}$  is the set resistance value, and  $\Delta I$  is the theoretical current deviation of the IT6600.

\*2. This specification was tested under test conditions with an output voltage of  $\geq 30V$ .

\*3. Multi-master cabinet, that is, optional emergency stop module (including AC contactor) models, the standard AC input voltage only supports  $380VAC \pm 10\%$ , such as the need for  $480VAC \pm 10\%$  voltage need to be customized.

\*4. Power factor of 0.99 at 50% of rated power and above at nominal input.

\*5. When the unit temperature exceeds  $40^{\circ}C$ , the rated current and power decrease by 3% for every  $1^{\circ}C$  increase. When the cabinet temperature exceeds  $30^{\circ}C$ , they decrease by 2% for every  $1^{\circ}C$  increase. Both are applicable up to a maximum of  $50^{\circ}C$ .

## IT66252D-1600-840

Parameter		IT66252D-1600-840	
Rated value	Voltage	Series mode	0 ~ 1600V
		2-channel mode/Parallel mode	0 ~ 800V
	Current	Parallel mode	0 ~ 840A
		2-channel mode/Series mode	0 ~ 420A
	Power	Each channel	0 ~ 126kW
		Total	0 ~ 252kW
	Resistance in series (CV priority)	2-channel mode	0 ~ 0.191 $\Omega$
		Parallel mode	0 ~ 0.096 $\Omega$
		Series mode	0 ~ 0.381 $\Omega$
	Load resistance (CC priority)	2-channel mode	0.011 ~ 7500 $\Omega$
Parallel mode		0.006 ~ 7500 $\Omega$	
Series mode		0.022 ~ 7500 $\Omega$	
Line Regulation	Voltage	$\leq 0.01\%FS$	
	Current	$\leq 0.01\%FS$	
Load Regulation	Voltage	$\leq 0.01\%FS$	
	Current	$\leq 0.02\%FS$	
Setup Resolution	Voltage	0.001V	
	Current	0.01A	
	Power	0.001kW	
	Resistance	0.001 $\Omega$	
Read Back Resolution	Voltage	0.001V	
	Current	0.01A	
	Power	0.001kW	
Setup Accuracy	Voltage	$\leq 0.02\% + 0.02\%FS$	
	Current	$\leq 0.03\% + 0.03\%FS$	
	Power	$\leq 0.05\% + 0.15\%FS$	
	Resistance *1	$\geq 0.5\%$	
Read Back Accuracy	Voltage	$\leq 0.02\% + 0.02\%FS$	

	Current	$\leq 0.03\% + 0.03\%FS$	
	Power	$\leq 0.05\% + 0.15\%FS$	
	Resistance *1	$\geq 0.5\%$	
Ripple *2	Vpp	20Hz-20MHz	$\leq 0.15\%FS$
	Vrms	20Hz-20MHz	$\leq 0.03\%FS$
	Irms	20Hz-300KHz	$\leq 0.15\%FS$
Setup Temperature Coefficient	Voltage	$\leq 15PPM/^{\circ}C$	
	Current	$\leq 30PPM/^{\circ}C$	
Read Back Temperature Coefficient	Voltage	$\leq 15PPM/^{\circ}C$	
	Current	$\leq 30PPM/^{\circ}C$	
Rise Time (no load)	Voltage	$\leq 2ms$	
Rise Time (full load)	Voltage	$\leq 2ms$	
Fall Time (no load)	Voltage	$\leq 1s$	
Fall Time (full load)	Voltage	$\leq 200ms$	
Rise Time (Full current)	Current	$\leq 2ms$	
Fall Time (Full current)	Current	$\leq 2ms$	
Transient Response Time (change from 40% to 90% of rated current)	Voltage	$\leq 1ms$	
AC Input	Input voltage *3	Three phase +PE	126 kW Max. @180-264V-Input 252 kW Max. @342-528V-Input
		Maximum Input Current	437A(per phase)@200Vac, 3 $\phi$ input 460A(per phase)@380Vac, 3 $\phi$ input 364A(per phase)@480Vac, 3 $\phi$ input
	Maximum Input Apparent Power	272.3kVA	
	Frequency	47Hz~63Hz	
	Power Factor *4	0.99	
	Setup Stability-30min	Voltage	$\leq 0.01\%+0.01\%FS$
Setup Stability-8h	Current	$\leq 0.02\%+0.02\%FS$	
	Voltage	$\leq 0.01\%+0.01\%FS$	
Readback Stability-30min	Current	$\leq 0.02\%+0.02\%FS$	
	Voltage	$\leq 0.01\%+0.01\%FS$	
Readback Stability-8h	Voltage	$\leq 0.01\%+0.01\%FS$	
	Current	$\leq 0.02\%+0.02\%FS$	
Efficiency	Full current and full power	$\sim 93.5\%$	
	Full voltage and full power	$\sim 94\%$	
Output Capacitance	2-channel mode	87.6 $\mu$ F/CH	
Remote Sense Voltage	1%FS		
Command Response Time	1ms		
Storage Temperature	$-10^{\circ}C \sim 70^{\circ}C$		
Protective Function	OVP, OCP, OPP, UVP, UCP, OTP, Vsense protection		
Standard Interface	Standard: USB, CAN, LAN, Digital IO Optional: GPIB, Analog/RS232), fiber optic socket, EtherCAT card, Relay cards		
Isolation (output to ground)	2250V		
Working Temperature *5	$0 \sim 50^{\circ}C$		

IP	IP20
Safety Standard	IEC 61010
Cooling	Air
NET Dimension ( mm)	600mm(W)* 1441.41mm(H)* 840.1mm(D) (Depth 1008.1mm including protective cover)
Weight( net)	447kg

\*1. This accuracy specification applies to output power in the range of 10% to 100%. When the output power is low, the resistance deviation ( $\Delta R$ ) can be approximated by:  $\Delta R \approx V / (V/R_{set} - \Delta I) - R_{set}$ . where  $V$  is the external voltage,  $R_{set}$  is the set resistance value, and  $\Delta I$  is the theoretical current deviation of the IT6600.

\*2. This specification was tested under test conditions with an output voltage of  $\geq 30V$ .

\*3. Multi-master cabinet, that is, optional emergency stop module (including AC contactor) models, the standard AC input voltage only supports  $380VAC \pm 10\%$ , such as the need for  $480VAC \pm 10\%$  voltage need to be customized.

\*4. Power factor of 0.99 at 50% of rated power and above at nominal input.

\*5. When the unit temperature exceeds  $40^{\circ}C$ , the rated current and power decrease by 3% for every  $1^{\circ}C$  increase. When the cabinet temperature exceeds  $30^{\circ}C$ , they decrease by 2% for every  $1^{\circ}C$  increase. Both are applicable up to a maximum of  $50^{\circ}C$ .

## IT66294D-1600-980

Parameter		IT66294D-1600-980	
Rated value	Voltage	Series mode	0 ~ 1600V
		2-channel mode/Parallel mode	0 ~ 800V
	Current	Parallel mode	0 ~ 980A
		2-channel mode/Series mode	0 ~ 490A
	Power	Each channel	0 ~ 147kW
		Total	0 ~ 294kW
	Resistance in series (CV priority)	2-channel mode	0 ~ 0.164 $\Omega$
		Parallel mode	0 ~ 0.082 $\Omega$
		Series mode	0 ~ 0.327 $\Omega$
	Load resistance (CC priority)	2-channel mode	0.01 ~ 7500 $\Omega$
Parallel mode		0.005 ~ 7500 $\Omega$	
Series mode		0.019 ~ 7500 $\Omega$	
Line Regulation	Voltage	$\leq 0.01\%FS$	
	Current	$\leq 0.01\%FS$	
Load Regulation	Voltage	$\leq 0.01\%FS$	
	Current	$\leq 0.02\%FS$	
Setup Resolution	Voltage	0.001V	
	Current	0.01A	
	Power	0.001kW	
	Resistance	0.001 $\Omega$	
Read Back Resolution	Voltage	0.001V	
	Current	0.01A	
	Power	0.001kW	
Setup Accuracy	Voltage	$\leq 0.02\% + 0.02\%FS$	
	Current	$\leq 0.03\% + 0.03\%FS$	

	Power	$\leq 0.05\% + 0.15\%FS$	
	Resistance *1	$\geq 0.5\%$	
Read Back Accuracy	Voltage	$\leq 0.02\% + 0.02\%FS$	
	Current	$\leq 0.03\% + 0.03\%FS$	
	Power	$\leq 0.05\% + 0.15\%FS$	
	Resistance *1	$\geq 0.5\%$	
Ripple *2	Vpp	20Hz-20MHz	$\leq 0.16\%FS$
	Vrms	20Hz-20MHz	$\leq 0.032\%FS$
	Irms	20Hz-300KHz	$\leq 0.16\%FS$
Setup Temperature Coefficient	Voltage	$\leq 15PPM/^{\circ}C$	
	Current	$\leq 30PPM/^{\circ}C$	
Read Back Temperature Coefficient	Voltage	$\leq 15PPM/^{\circ}C$	
	Current	$\leq 30PPM/^{\circ}C$	
Rise Time (no load)	Voltage	$\leq 2ms$	
Rise Time (full load)	Voltage	$\leq 2ms$	
Fall Time (no load)	Voltage	$\leq 1s$	
Fall Time (full load)	Voltage	$\leq 200ms$	
Rise Time (Full current)	Current	$\leq 2ms$	
Fall Time (Full current)	Current	$\leq 2ms$	
Transient Response Time (change from 40% to 90% of rated current)	Voltage	$\leq 1ms$	
AC Input	Input voltage *3	Three phase +PE	147 kW Max. @180-264V-Input 294 kW Max. @342-528V-Input
		Maximum Input Current	510A(per phase)@200Vac, 3 $\phi$ input 537A(per phase)@380Vac, 3 $\phi$ input 425A(per phase)@480Vac, 3 $\phi$ input
	Maximum Input Apparent Power	317.7kVA	
	Frequency	47Hz~63Hz	
	Power Factor *4	0.99	
	Setup Stability-30min	Voltage	$\leq 0.01\% + 0.01\%FS$
Current		$\leq 0.02\% + 0.02\%FS$	
Setup Stability-8h	Voltage	$\leq 0.01\% + 0.01\%FS$	
	Current	$\leq 0.02\% + 0.02\%FS$	
Readback Stability-30min	Voltage	$\leq 0.01\% + 0.01\%FS$	
	Current	$\leq 0.02\% + 0.02\%FS$	
Readback Stability-8h	Voltage	$\leq 0.01\% + 0.01\%FS$	
	Current	$\leq 0.02\% + 0.02\%FS$	
Efficiency	Full current and full power	$\sim 93.5\%$	
	Full voltage and full power	$\sim 94\%$	
Output Capacitance	2-channel mode	102.2uF/CH	
Remote Sense Voltage	1%FS		
Command Response Time	1ms		
Storage Temperature	$-10^{\circ}C \sim 70^{\circ}C$		
Protective Function	OVP, OCP, OPP, UVP, UCP, OTP, Vsense protection		
Standard Interface	Standard: USB, CAN, LAN, Digital IO Optional: GPIB, Analog/RS232), fiber optic socket, EtherCAT card, Relay cards		

Isolation (output to ground)	2250V
Working Temperature *5	0~50°C
IP	IP20
Safety Standard	IEC 61010
Cooling	Air
Dimension ( mm)	600mm(W)* 1441.41mm(H)* 840.1mm(D) (Depth 1008.1mm including protective cover)
Weight( net)	497kg

\*1. This accuracy specification applies to output power in the range of 10% to 100%. When the output power is low, the resistance deviation ( $\Delta R$ ) can be approximated by:  $\Delta R \approx V / (V/R_{set} - \Delta I) - R_{set}$ . where  $V$  is the external voltage,  $R_{set}$  is the set resistance value, and  $\Delta I$  is the theoretical current deviation of the IT6600.

\*2. This specification was tested under test conditions with an output voltage of  $\geq 30V$ .

\*3. Multi-master cabinet, that is, optional emergency stop module (including AC contactor) models, the standard AC input voltage only supports 380VAC  $\pm 10\%$ , such as the need for 480VAC  $\pm 10\%$  voltage need to be customized.

\*4. Power factor of 0.99 at 50% of rated power and above at nominal input.

\*5. When the unit temperature exceeds 40°C, the rated current and power decrease by 3% for every 1°C increase. When the cabinet temperature exceeds 30°C, they decrease by 2% for every 1°C increase. Both are applicable up to a maximum of 50°C.

## IT66336D-1600-1120

Parameter		IT66336D-1600-1120	
Rated value	Voltage	Series mode	0 ~ 1600V
		2-channel mode/Parallel mode	0 ~ 800V
	Current	Parallel mode	0 ~ 1120A
		2-channel mode/Series mode	0 ~ 560A
	Power	Each channel	0 ~ 168kW
		Total	0 ~ 336kW
	Resistance in series (CV priority)	2-channel mode	0 ~ 0.143Ω
		Parallel mode	0 ~ 0.072Ω
		Series mode	0 ~ 0.286Ω
	Load resistance (CC priority)	2-channel mode	0.009 ~ 7500Ω
Parallel mode		0.005 ~ 7500Ω	
Series mode		0.017 ~ 7500Ω	
Line Regulation	Voltage	$\leq 0.01\%FS$	
	Current	$\leq 0.01\%FS$	
Load Regulation	Voltage	$\leq 0.01\%FS$	
	Current	$\leq 0.02\%FS$	
Setup Resolution	Voltage	0.001V	
	Current	0.01A	
	Power	0.001kW	
	Resistance	0.001Ω	
Read Back Resolution	Voltage	0.001V	
	Current	0.01A	

	Power	0.001kW	
Setup Accuracy	Voltage	$\leq 0.02\% + 0.02\%FS$	
	Current	$\leq 0.03\% + 0.03\%FS$	
	Power	$\leq 0.05\% + 0.15\%FS$	
	Resistance *1	$\geq 0.5\%$	
Read Back Accuracy	Voltage	$\leq 0.02\% + 0.02\%FS$	
	Current	$\leq 0.03\% + 0.03\%FS$	
	Power	$\leq 0.05\% + 0.15\%FS$	
	Resistance *1	$\geq 0.5\%$	
Ripple *2	Vpp	20Hz-20MHz	$\leq 0.17\%FS$
	Vrms	20Hz-20MHz	$\leq 0.034\%FS$
	Irms	20Hz-300KHz	$\leq 0.17\%FS$
Setup Temperature Coefficient	Voltage	$\leq 15PPM/^{\circ}C$	
	Current	$\leq 30PPM/^{\circ}C$	
Read Back Temperature Coefficient	Voltage	$\leq 15PPM/^{\circ}C$	
	Current	$\leq 30PPM/^{\circ}C$	
Rise Time (no load)	Voltage	$\leq 2ms$	
Rise Time (full load)	Voltage	$\leq 2ms$	
Fall Time (no load)	Voltage	$\leq 1s$	
Fall Time (full load)	Voltage	$\leq 200ms$	
Rise Time (Full current)	Current	$\leq 2ms$	
Fall Time (Full current)	Current	$\leq 2ms$	
Transient Response Time (change from 40% to 90% of rated current)	Voltage	$\leq 1ms$	
AC Input	Input voltage *3	Three phase +PE	168 kW Max. @ 180-264V-Input
			336 kW Max. @ 342-528V-Input
	Maximum Input Current	583A(per phase)@200Vac, 3 $\phi$ input	
		613A(per phase)@380Vac, 3 $\phi$ input	
		486A(per phase)@480Vac, 3 $\phi$ input	
	Maximum Input Apparent Power	363kVA	
Frequency	47Hz~63Hz		
Power Factor *4	0.99		
Setup Stability-30min	Voltage	$\leq 0.01\% + 0.01\%FS$	
	Current	$\leq 0.02\% + 0.02\%FS$	
Setup Stability-8h	Voltage	$\leq 0.01\% + 0.01\%FS$	
	Current	$\leq 0.02\% + 0.02\%FS$	
Readback Stability-30min	Voltage	$\leq 0.01\% + 0.01\%FS$	
	Current	$\leq 0.02\% + 0.02\%FS$	
Readback Stability-8h	Voltage	$\leq 0.01\% + 0.01\%FS$	
	Current	$\leq 0.02\% + 0.02\%FS$	
Efficiency	Full current and full power	$\sim 93.5\%$	
	Full voltage and full power	$\sim 94\%$	
Output Capacitance	2-channel mode	116.8uF/CH	
Remote Sense Voltage	1%FS		
Command Response Time	1ms		
Storage Temperature	$-10^{\circ}C \sim 70^{\circ}C$		
Protective Function	OVP, OCP, OPP, UVP, UCP, OTP, Vsense protection		

Standard Interface	Standard: USB, CAN, LAN, Digital IO Optional: GPIB, Analog/RS232), fiber optic socket, EtherCAT card, Relay cards
Isolation (output to ground)	2250V
Working Temperature *5	0~50°C
IP	IP20
Safety Standard	IEC 61010
Cooling	Air
Dimension ( mm)	600mm(W)* 1885.91mm(H)* 840.1mm(D) (Depth 1008.1mm including protective cover)
Weight( net)	583kg

\*1. This accuracy specification applies to output power in the range of 10% to 100%. When the output power is low, the resistance deviation ( $\Delta R$ ) can be approximated by:  $\Delta R \approx V / (V/R_{set} - \Delta I) - R_{set}$ . where  $V$  is the external voltage,  $R_{set}$  is the set resistance value, and  $\Delta I$  is the theoretical current deviation of the IT6600.

\*2. This specification was tested under test conditions with an output voltage of  $\geq 30V$ .

\*3. Multi-master cabinet, that is, optional emergency stop module (including AC contactor) models, the standard AC input voltage only supports 380VAC  $\pm 10\%$ , such as the need for 480VAC  $\pm 10\%$  voltage need to be customized.

\*4. Power factor of 0.99 at 50% of rated power and above at nominal input.

\*5. When the unit temperature exceeds 40°C, the rated current and power decrease by 3% for every 1°C increase. When the cabinet temperature exceeds 30°C, they decrease by 2% for every 1°C increase. Both are applicable up to a maximum of 50°C.

## IT66378D-1600-1260

Parameter		IT66378D-1600-1260	
Rated value	Voltage	Series mode	0 ~ 1600V
		2-channel mode/Parallel mode	0 ~ 800V
	Current	Parallel mode	0 ~ 1260A
		2-channel mode/Series mode	0 ~ 630A
	Power	Each channel	0 ~ 189kW
		Total	0 ~ 378kW
	Resistance in series (CV priority)	2-channel mode	0 ~ 0.127Ω
		Parallel mode	0 ~ 0.064Ω
		Series mode	0 ~ 0.254Ω
	Load resistance (CC priority)	2-channel mode	0.008 ~ 7500Ω
Parallel mode		0.004 ~ 7500Ω	
Series mode		0.015 ~ 7500Ω	
Line Regulation	Voltage	$\leq 0.01\%FS$	
	Current	$\leq 0.01\%FS$	
Load Regulation	Voltage	$\leq 0.01\%FS$	
	Current	$\leq 0.02\%FS$	
Setup Resolution	Voltage	0.001V	
	Current	0.01A	
	Power	0.001kW	
	Resistance	0.001Ω	

Read Back Resolution	Voltage	0.001V	
	Current	0.01A	
	Power	0.001kW	
Setup Accuracy	Voltage	$\leq 0.02\% + 0.02\%FS$	
	Current	$\leq 0.03\% + 0.03\%FS$	
	Power	$\leq 0.05\% + 0.15\%FS$	
	Resistance *1	$\geq 0.5\%$	
Read Back Accuracy	Voltage	$\leq 0.02\% + 0.02\%FS$	
	Current	$\leq 0.03\% + 0.03\%FS$	
	Power	$\leq 0.05\% + 0.15\%FS$	
	Resistance *1	$\geq 0.5\%$	
Ripple *2	Vpp	20Hz-20MHz	$\leq 0.18\%FS$
	Vrms	20Hz-20MHz	$\leq 0.036\%FS$
	Irms	20Hz-300KHz	$\leq 0.18\%FS$
Setup Temperature Coefficient	Voltage	$\leq 15PPM/^{\circ}C$	
	Current	$\leq 30PPM/^{\circ}C$	
Read Back Temperature Coefficient	Voltage	$\leq 15PPM/^{\circ}C$	
	Current	$\leq 30PPM/^{\circ}C$	
Rise Time (no load)	Voltage	$\leq 2ms$	
Rise Time (full load)	Voltage	$\leq 2ms$	
Fall Time (no load)	Voltage	$\leq 1s$	
Fall Time (full load)	Voltage	$\leq 200ms$	
Rise Time (Full current)	Current	$\leq 2ms$	
Fall Time (Full current)	Current	$\leq 2ms$	
Transient Response Time (change from 40% to 90% of rated current)	Voltage	$\leq 1ms$	
AC Input	Input voltage *3	Three phase +PE	189 kW Max. @180-264V-Input
			378 kW Max. @342-528V-Input
	Maximum Input Current	655A(per phase)@200Vac, 3 $\phi$ input	
		690A(per phase)@380Vac, 3 $\phi$ input	
		546A(per phase)@480Vac, 3 $\phi$ input	
	Maximum Input Apparent Power	408.4kVA	
Frequency	47Hz~63Hz		
Power Factor *4	0.99		
Setup Stability-30min	Voltage	$\leq 0.01\% + 0.01\%FS$	
	Current	$\leq 0.02\% + 0.02\%FS$	
Setup Stability-8h	Voltage	$\leq 0.01\% + 0.01\%FS$	
	Current	$\leq 0.02\% + 0.02\%FS$	
Readback Stability-30min	Voltage	$\leq 0.01\% + 0.01\%FS$	
	Current	$\leq 0.02\% + 0.02\%FS$	
Readback Stability-8h	Voltage	$\leq 0.01\% + 0.01\%FS$	
	Current	$\leq 0.02\% + 0.02\%FS$	
Efficiency	Full current and full power	~93.5%	
	Full voltage and full power	~94%	
Output Capacitance	2-channel mode	131.4uF/CH	
Remote Sense Voltage	1%FS		

Command Response Time	1ms
Storage Temperature	-10°C ~ 70°C
Protective Function	OVP, OCP, OPP, UVP, UCP, OTP, Vsense protection
Standard Interface	Standard: USB, CAN, LAN, Digital IO Optional: GPIB, Analog/RS232), fiber optic socket, EtherCAT card, Relay cards
Isolation (output to ground)	2250V
Working Temperature *5	0 ~ 50°C
IP	IP20
Safety Standard	IEC 61010
Cooling	Air
Dimension ( mm)	600mm(W)* 1885.91mm(H)* 840.1mm(D) (Depth 1008.1mm including protective cover)
Weight( net)	633kg

\*1. This accuracy specification applies to output power in the range of 10% to 100%. When the output power is low, the resistance deviation ( $\Delta R$ ) can be approximated by:  $\Delta R \approx V / (V/R_{set} - \Delta I) - R_{set}$ . where  $V$  is the external voltage,  $R_{set}$  is the set resistance value, and  $\Delta I$  is the theoretical current deviation of the IT6600.

\*2. This specification was tested under test conditions with an output voltage of  $\geq 30V$ .

\*3. Multi-master cabinet, that is, optional emergency stop module (including AC contactor) models, the standard AC input voltage only supports 380VAC  $\pm 10\%$ , such as the need for 480VAC  $\pm 10\%$  voltage need to be customized.

\*4. Power factor of 0.99 at 50% of rated power and above at nominal input.

\*5. When the unit temperature exceeds 40°C, the rated current and power decrease by 3% for every 1°C increase. When the cabinet temperature exceeds 30°C, they decrease by 2% for every 1°C increase. Both are applicable up to a maximum of 50°C.

## IT66420D-1600-1400

Parameter		IT66420D-1600-1400	
Rated value	Voltage	Series mode	0 ~ 1600V
		2-channel mode/Parallel mode	0 ~ 800V
	Current	Parallel mode	0 ~ 1400A
		2-channel mode/Series mode	0 ~ 700A
	Power	Each channel	0 ~ 210kW
		Total	0 ~ 420kW
	Resistance in series (CV priority)	2-channel mode	0 ~ 0.115Ω
		Parallel mode	0 ~ 0.058Ω
		Series mode	0 ~ 0.229Ω
	Load resistance (CC priority)	2-channel mode	0.007 ~ 7500Ω
Parallel mode		0.004 ~ 7500Ω	
Series mode		0.014 ~ 7500Ω	
Line Regulation	Voltage	$\leq 0.01\%FS$	
	Current	$\leq 0.01\%FS$	
Load Regulation	Voltage	$\leq 0.01\%FS$	
	Current	$\leq 0.02\%FS$	
Setup Resolution	Voltage	0.001V	

	Current	0.01A	
	Power	0.001kW	
	Resistance	0.001Ω	
Read Back Resolution	Voltage	0.001V	
	Current	0.01A	
	Power	0.001kW	
Setup Accuracy	Voltage	≤0.02%+0.02%FS	
	Current	≤0.03% + 0.03%FS	
	Power	≤0.05% + 0.15%FS	
	Resistance *1	≥0.5%	
Read Back Accuracy	Voltage	≤0.02%+0.02%FS	
	Current	≤0.03% + 0.03%FS	
	Power	≤0.05% + 0.15%FS	
	Resistance *1	≥0.5%	
Ripple *2	Vpp	20Hz-20MHz	≤0.19%FS
	Vrms	20Hz-20MHz	≤0.038%FS
	Irms	20Hz-300KHz	≤0.19%FS
Setup Temperature Coefficient	Voltage	≤15PPM/°C	
	Current	≤30PPM/°C	
Read Back Temperature Coefficient	Voltage	≤15PPM/°C	
	Current	≤30PPM/°C	
Rise Time (no load)	Voltage	≤2ms	
Rise Time (full load)	Voltage	≤2ms	
Fall Time (no load)	Voltage	≤1s	
Fall Time (full load)	Voltage	≤200ms	
Rise Time (Full current)	Current	≤2ms	
Fall Time (Full current)	Current	≤2ms	
Transient Response Time (change from 40% to 90% of rated current)	Voltage	≤1ms	
AC Input	Input voltage *3	Three phase +PE	210 kW Max. @180-264V-Input
			420 kW Max. @342-528V-Input
	Maximum Input Current	728A(per phase)@200Vac, 3ø input	
		766A(per phase)@380Vac, 3ø input	
		607A(per phase)@480Vac, 3ø input	
	Maximum Input Apparent Power	453.8kVA	
Frequency	47Hz~63Hz		
Power Factor *4	0.99		
Setup Stability-30min	Voltage	≤0.01%+0.01%FS	
	Current	≤0.02%+0.02%FS	
Setup Stability-8h	Voltage	≤0.01%+0.01%FS	
	Current	≤0.02%+0.02%FS	
Readback Stability-30min	Voltage	≤0.01%+0.01%FS	
	Current	≤0.02%+0.02%FS	
Readback Stability-8h	Voltage	≤0.01%+0.01%FS	
	Current	≤0.02%+0.02%FS	
Efficiency	Full current and full power	~93.5%	

	Full voltage and full power	~94%
Output Capacitance	2-channel mode	146uF/CH
Remote Sense Voltage	1%FS	
Command Response Time	1ms	
Storage Temperature	-10°C~70°C	
Protective Function	OVP, OCP, OPP, UVP, UCP, OTP, Vsense protection	
Standard Interface	Standard: USB, CAN, LAN, Digital IO Optional: GPIB, Analog/RS232), fiber optic socket, EtherCAT card, Relay cards	
Isolation (output to ground)	2250V	
Working Temperature *5	0~50°C	
IP	IP20	
Safety Standard	IEC 61010	
Cooling	Air	
Dimension ( mm)	600mm(W)* 1885.91mm(H)* 840.1mm(D) (Depth 1008.1mm including protective cover)	
Weight( net)	683kg	

\*1. This accuracy specification applies to output power in the range of 10% to 100%. When the output power is low, the resistance deviation ( $\Delta R$ ) can be approximated by:  $\Delta R \approx V / (V/R_{set} - \Delta I) - R_{set}$ . where  $V$  is the external voltage,  $R_{set}$  is the set resistance value, and  $\Delta I$  is the theoretical current deviation of the IT6600.

\*2. This specification was tested under test conditions with an output voltage of  $\geq 30V$ .

\*3. Multi-master cabinet, that is, optional emergency stop module (including AC contactor) models, the standard AC input voltage only supports 380VAC  $\pm 10\%$ , such as the need for 480VAC  $\pm 10\%$  voltage need to be customized.

\*4. Power factor of 0.99 at 50% of rated power and above at nominal input.

\*5. When the unit temperature exceeds 40°C, the rated current and power decrease by 3% for every 1°C increase. When the cabinet temperature exceeds 30°C, they decrease by 2% for every 1°C increase. Both are applicable up to a maximum of 50°C.

## IT6642D-2250-100

Parameter		IT6642D-2250-100	
Rated value	Voltage	Series mode	0~2250V
		2-channel mode/Parallel mode	0~1200V
	Current	Parallel mode	0~100A
		2-channel mode/Series mode	0~50A
	Power	Each channel	0~21kW
		Total	0~42kW
	Resistance in series (CV priority)	2-channel mode	0~2.4Ω
		Parallel mode	0~1.2Ω
		Series mode	0~4.5Ω
	Load resistance (CC priority)	2-channel mode	0.092~7500Ω
Parallel mode		0.046~7500Ω	
Series mode		0.183~7500Ω	
Line Regulation	Voltage	$\leq 0.005\%FS$	
	Current	$\leq 0.005\%FS$	

Load Regulation	Voltage	$\leq 0.005\%FS$	
	Current	$\leq 0.015\%FS$	
Setup Resolution	Voltage	0.001V	
	Current	0.001A	
	Power	0.001kW	
	Resistance	0.001 $\Omega$	
Read Back Resolution	Voltage	0.001V	
	Current	0.001A	
	Power	0.001kW	
Setup Accuracy	Voltage	$\leq 0.02\%+0.01\%FS$	
	Current	$\leq 0.03\% + 0.03\%FS$	
	Power	$\leq 0.05\% + 0.15\%FS$	
	Resistance *1	$\leq 0.5\%$	
Read Back Accuracy	Voltage	$\leq 0.02\%+0.01\%FS$	
	Current	$\leq 0.03\% + 0.03\%FS$	
	Power	$\leq 0.05\% + 0.15\%FS$	
	Resistance *1	$\leq 0.5\%$	
Ripple *2	Vpp	20Hz-20MHz	$\leq 0.1\%FS$
	Vrms	20Hz-20MHz	$\leq 0.02\%FS$
	Irms	20Hz-300KHz	$\leq 0.1\%FS$
Setup Temperature Coefficient	Voltage	$\leq 15PPM/^{\circ}C$	
	Current	$\leq 30PPM/^{\circ}C$	
Read Back Temperature Coefficient	Voltage	$\leq 15PPM/^{\circ}C$	
	Current	$\leq 30PPM/^{\circ}C$	
Rise Time( no load )	Voltage	$\leq 1ms$	
Rise Time( full load )	Voltage	$\leq 1ms$	
Fall Time( no load )	Voltage	$\leq 1s$	
Fall Time( full load )	Voltage	$\leq 100ms$	
Rise Time( full current )	Current	$\leq 1ms$	
Fall Time( full current )	Current	$\leq 1ms$	
Transient Response Time (change from 40% to 90% of rated current)	Voltage	$\leq 200us$	
AC Input	Input voltage *3	Three phase + PE	21 kW Max. @180-264V-Input
			42 kW Max. @342-528V-Input
	Maximum Input Current	73A(per phase)@200Vac, 3 $\phi$ input	
		77A(per phase)@380Vac, 3 $\phi$ input	
		61A(per phase)@480Vac, 3 $\phi$ input	
	Maximum Input Apparent Power	45.4kVA	
Frequency	47Hz~63Hz		
Power Factor *4	0.99		
Setup Stability-30min	Voltage	$\leq 0.005\%+0.005\%FS$	
	Current	$\leq 0.01\%+0.01\%FS$	
Setup Stability-8h	Voltage	$\leq 0.005\%+0.005\%FS$	
	Current	$\leq 0.01\%+0.01\%FS$	
Readback Stability-30min	Voltage	$\leq 0.005\%+0.005\%FS$	
	Current	$\leq 0.01\%+0.01\%FS$	
Readback Stability-8h	Voltage	$\leq 0.005\%+0.005\%FS$	

	Current	$\leq 0.01\% + 0.01\%FS$	
Efficiency	Full current and full power	~93.5%	
	Full voltage and full power	~94%	
Output Port Capacitance	2-channel mode	14.6uF/CH	
Remote Sense Voltage	1%FS		
Command Response Time	1ms		
Storage Temperature	-10°C~70°C		
Protective Function	OVP, OCP, OPP, UVP, UCP, OTP, Vsense protection		
Standard Interface	Standard: USB, CAN, LAN, Digital IO Optional: GPIB, Analog/RS232, fiber optic socket, EtherCAT card, Relay cards		
Isolation (output to ground)	2250V		
Working Temperature *5	0~50°C		
IP	IP20		
Safety Standard	IEC 61010		
Cooling	Air		
Dimension (mm)	483mm(W)* 151.3mm(H)* 831.6mm(D)		
Weight (net)	50kg		

\*1. This accuracy specification applies to output power in the range of 10% to 100%. When the output power is low, the resistance deviation ( $\Delta R$ ) can be approximated by:  $\Delta R \approx V / (V/R_{set} - \Delta I) - R_{set}$ . where  $V$  is the external voltage,  $R_{set}$  is the set resistance value, and  $\Delta I$  is the theoretical current deviation of the IT6600.

\*2. This specification was tested under test conditions with an output voltage of  $\geq 30V$ .

\*3. Multi-master cabinet, that is, optional emergency stop module (including AC contactor) models, the standard AC input voltage only supports  $380VAC \pm 10\%$ , such as the need for  $480VAC \pm 10\%$  voltage need to be customized.

\*4. Power factor of 0.99 at 50% of rated power and above at nominal input.

\*5. When the unit temperature exceeds 40°C, the rated current and power decrease by 3% for every 1°C increase. When the cabinet temperature exceeds 30°C, they decrease by 2% for every 1°C increase. Both are applicable up to a maximum of 50°C.

## IT6684D-2250-200

Parameter		IT6684D-2250-200	
Rated value	Voltage	Series mode	0 ~ 2250V
		2-channel mode/Parallel mode	0 ~ 1200V
	Current	Parallel mode	0 ~ 200A
		2-channel mode/Series mode	0 ~ 100A
	Power	Each channel	0 ~ 42kW
		Total	0 ~ 84kW
	Resistance in series (CV priority)	2-channel mode	0 ~ 1.2Ω
		Parallel mode	0 ~ 0.6Ω
		Series mode	0 ~ 2.25Ω
	Load resistance (CC priority)	2-channel mode	0.046 ~ 7500Ω
Parallel mode		0.023 ~ 7500Ω	

		Series mode	0.092 ~ 7500Ω
Line Regulation	Voltage		≤0.005%FS
	Current		≤0.005%FS
Load Regulation	Voltage		≤0.005%FS
	Current		≤0.015%FS
Setup Resolution	Voltage		0.001V
	Current		0.001A
	Power		0.001kW
	Resistance		0.001Ω
Read Back Resolution	Voltage		0.001V
	Current		0.001A
	Power		0.001kW
Setup Accuracy	Voltage		≤0.02%+0.01%FS
	Current		≤0.03% + 0.03%FS
	Power		≤0.05% + 0.15%FS
	Resistance *1		≥0.5%
Read Back Accuracy	Voltage		≤0.02%+0.01%FS
	Current		≤0.03% + 0.03%FS
	Power		≤0.05% + 0.15%FS
	Resistance *1		≥0.5%
Ripple *2	Vpp	20Hz-20MHz	≤0.11%FS
	Vrms	20Hz-20MHz	≤0.022%FS
	Irms	20Hz-300KHz	≤0.11%FS
Setup Temperature Coefficient	Voltage		≤15PPM/°C
	Current		≤30PPM/°C
Read Back Temperature Coefficient	Voltage		≤15PPM/°C
	Current		≤30PPM/°C
Rise Time (no load)	Voltage		≤1ms
Rise Time (full load)	Voltage		≤1ms
Fall Time (no load)	Voltage		≤1s
Fall Time (full load)	Voltage		≤100ms
Rise Time (Full current)	Current		≤1ms
Fall Time (Full current)	Current		≤1ms
Transient Response Time (change from 40% to 90% of rated current)	Voltage		≤200us
AC Input	Input voltage *3	Three phase +PE	42 kW Max. @180-264V-Input
			84 kW Max. @342-528V-Input
	Maximum Input Current	146A(per phase)@200Vac, 3ø input	
		154A(per phase)@380Vac, 3ø input	
		122A(per phase)@480Vac, 3ø input	
	Maximum Input Apparent Power	90.8kVA	
Frequency	47Hz~63Hz		
Power Factor *4	0.99		
Setup Stability-30min	Voltage		≤0.005%+0.005%FS
	Current		≤0.01%+0.01%FS
Setup Stability-8h	Voltage		≤0.005%+0.005%FS
	Current		≤0.01%+0.01%FS

Readback Stability-30min	Voltage	≤0.005%+0.005%FS	
	Current	≤0.01%+0.01%FS	
Readback Stability-8h	Voltage	≤0.005%+0.005%FS	
	Current	≤0.01%+0.01%FS	
Efficiency		Full current and full power	~93.5%
		Full voltage and full power	~94%
Output Capacitance		2-channel mode	29.2uF/CH
Remote Sense Voltage		1%FS	
Command Response Time		1ms	
Storage Temperature		-10℃~70℃	
Protective Function		OVP, OCP, OPP, UVP, UCP, OTP, Vsense protection	
Standard Interface		Standard: USB, CAN, LAN, Digital IO Optional: GPIB, Analog/RS232, fiber optic socket, EtherCAT card, Relay cards	
Isolation (output to ground)		2250V	
Working Temperature *5		0~50℃	
IP		IP20	
Safety Standard		IEC 61010	
Cooling		Air	
Dimension ( mm)		500mm(W)* 907.64mm(H)* 841.1mm(D) (Depth 1008.1mm including protective cover)	
Weight( net)		186kg	

\*1. This accuracy specification applies to output power in the range of 10% to 100%. When the output power is low, the resistance deviation ( $\Delta R$ ) can be approximated by:  $\Delta R \approx V / (V/R_{set} - \Delta I) - R_{set}$ . where  $V$  is the external voltage,  $R_{set}$  is the set resistance value, and  $\Delta I$  is the theoretical current deviation of the IT6600.

\*2. This specification was tested under test conditions with an output voltage of  $\geq 30V$ .

\*3. Multi-master cabinet, that is, optional emergency stop module (including AC contactor) models, the standard AC input voltage only supports 380VAC  $\pm 10\%$ , such as the need for 480VAC  $\pm 10\%$  voltage need to be customized.

\*4. Power factor of 0.99 at 50% of rated power and above at nominal input.

\*5. When the unit temperature exceeds 40℃, the rated current and power decrease by 3% for every 1℃ increase. When the cabinet temperature exceeds 30℃, they decrease by 2% for every 1℃ increase. Both are applicable up to a maximum of 50℃.

## IT66126D-2250-300

Parameter		IT66126D-2250-300	
Rated value	Voltage	Series mode	0 ~ 2250V
		2-channel mode/Parallel mode	0 ~ 1200V
	Current	Parallel mode	0 ~ 300A
		2-channel mode/Series mode	0 ~ 150A
	Power	Each channel	0 ~ 63kW
		Total	0 ~ 126kW
	Resistance in	2-channel mode	0 ~ 0.8Ω

	series (CV priority)	Parallel mode	0 ~ 0.4Ω
		Series mode	0 ~ 1.5Ω
	Load resistance (CC priority)	2-channel mode	0.031 ~ 7500Ω
		Parallel mode	0.016 ~ 7500Ω
		Series mode	0.061 ~ 7500Ω
Line Regulation	Voltage	≤0.005%FS	
	Current	≤0.005%FS	
Load Regulation	Voltage	≤0.005%FS	
	Current	≤0.015%FS	
Setup Resolution	Voltage	0.001V	
	Current	0.001A	
	Power	0.001kW	
	Resistance	0.001Ω	
Read Back Resolution	Voltage	0.001V	
	Current	0.001A	
	Power	0.001kW	
Setup Accuracy	Voltage	≤0.02%+0.01%FS	
	Current	≤0.03% + 0.03%FS	
	Power	≤0.05% + 0.15%FS	
	Resistance *1	≥0.5%	
Read Back Accuracy	Voltage	≤0.02%+0.01%FS	
	Current	≤0.03% + 0.03%FS	
	Power	≤0.05% + 0.15%FS	
	Resistance *1	≥0.5%	
Ripple *2	Vpp	20Hz-20MHz	≤0.12%FS
	Vrms	20Hz-20MHz	≤0.024%FS
	Irms	20Hz-300KHz	≤0.12%FS
Setup Temperature Coefficient	Voltage	≤15PPM/°C	
	Current	≤30PPM/°C	
Read Back Temperature Coefficient	Voltage	≤15PPM/°C	
	Current	≤30PPM/°C	
Rise Time (no load)	Voltage	≤1ms	
Rise Time (full load)	Voltage	≤1ms	
Fall Time (no load)	Voltage	≤1s	
Fall Time (full load)	Voltage	≤100ms	
Rise Time (Full current)	Current	≤1ms	
Fall Time (Full current)	Current	≤1ms	
Transient Response Time (change from 40% to 90% of rated current)	Voltage	≤200us	
AC Input	Input voltage *3	Three phase +PE	63 kW Max. @180-264V-Input
			126 kW Max. @342-528V-Input
	Maximum Input Current	219A(per phase)@200Vac, 3ø input	
		230A(per phase)@380Vac, 3ø input	
		182A(per phase)@480Vac, 3ø input	
	Maximum Input Apparent Power	136.2kVA	
Frequency	47Hz~63Hz		
Power Factor *4	0.99		

Setup Stability-30min	Voltage	≤0.005%+0.005%FS	
	Current	≤0.01%+0.01%FS	
Setup Stability-8h	Voltage	≤0.005%+0.005%FS	
	Current	≤0.01%+0.01%FS	
Readback Stability-30min	Voltage	≤0.005%+0.005%FS	
	Current	≤0.01%+0.01%FS	
Readback Stability-8h	Voltage	≤0.005%+0.005%FS	
	Current	≤0.01%+0.01%FS	
Efficiency		Full current and full power	~93.5%
		Full voltage and full power	~94%
Output Capacitance		2-channel mode	43.8uF/CH
Remote Sense Voltage		1%FS	
Command Response Time		1ms	
Storage Temperature		-10℃~70℃	
Protective Function		OVP, OCP, OPP, UVP, UCP, OTP, Vsense protection	
Standard Interface		Standard: USB, CAN, LAN, Digital IO Optional: GPIB, Analog/RS232), fiber optic socket, EtherCAT card, Relay cards	
Isolation (output to ground)		2250V	
Working Temperature *5		0~50℃	
IP		IP20	
Safety Standard		IEC 61010	
Cooling		Air	
Dimension ( mm)		500mm(W)* 907.64mm(H)* 841.1mm(D) (Depth 1008.1mm including protective cover)	
Weight( net)		237kg	

\*1. This accuracy specification applies to output power in the range of 10% to 100%. When the output power is low, the resistance deviation ( $\Delta R$ ) can be approximated by:  $\Delta R \approx V / (V/R_{set} - \Delta I) - R_{set}$ . where  $V$  is the external voltage,  $R_{set}$  is the set resistance value, and  $\Delta I$  is the theoretical current deviation of the IT6600.

\*2. This specification was tested under test conditions with an output voltage of  $\geq 30V$ .

\*3. Multi-master cabinet, that is, optional emergency stop module (including AC contactor) models, the standard AC input voltage only supports 380VAC  $\pm 10\%$ , such as the need for 480VAC  $\pm 10\%$  voltage need to be customized.

\*4. Power factor of 0.99 at 50% of rated power and above at nominal input.

\*5. When the unit temperature exceeds 40℃, the rated current and power decrease by 3% for every 1℃ increase. When the cabinet temperature exceeds 30℃, they decrease by 2% for every 1℃ increase. Both are applicable up to a maximum of 50℃.

## IT66168D-2250-400

Parameter		IT66168D-2250-400	
Rated value	Voltage	Series mode	0 ~ 2250V
		2-channel mode/Parallel mode	0 ~ 1200V
	Current	Parallel mode	0 ~ 400A

		2-channel mode/Series mode	0 ~ 200A
	Power	Each channel	0 ~ 84kW
		Total	0 ~ 168kW
	Resistance in series (CV priority)	2-channel mode	0 ~ 0.6Ω
		Parallel mode	0 ~ 0.3Ω
		Series mode	0 ~ 1.125Ω
	Load resistance (CC priority)	2-channel mode	0.023 ~ 7500Ω
Parallel mode		0.012 ~ 7500Ω	
Series mode		0.046 ~ 7500Ω	
Line Regulation	Voltage	≤0.005%FS	
	Current	≤0.005%FS	
Load Regulation	Voltage	≤0.005%FS	
	Current	≤0.015%FS	
Setup Resolution	Voltage	0.001V	
	Current	0.001A	
	Power	0.001kW	
	Resistance	0.001Ω	
Read Back Resolution	Voltage	0.001V	
	Current	0.001A	
	Power	0.001kW	
Setup Accuracy	Voltage	≤0.02%+0.01%FS	
	Current	≤0.03% + 0.03%FS	
	Power	≤0.05% + 0.15%FS	
	Resistance *1	≥0.5%	
Read Back Accuracy	Voltage	≤0.02%+0.01%FS	
	Current	≤0.03% + 0.03%FS	
	Power	≤0.05% + 0.15%FS	
	Resistance *1	≥0.5%	
Ripple *2	Vpp	20Hz-20MHz	≤0.13%FS
	Vrms	20Hz-20MHz	≤0.026%FS
	Irms	20Hz-300KHz	≤0.13%FS
Setup Temperature Coefficient	Voltage	≤15PPM/°C	
	Current	≤30PPM/°C	
Read Back Temperature Coefficient	Voltage	≤15PPM/°C	
	Current	≤30PPM/°C	
Rise Time (no load)	Voltage	≤1ms	
Rise Time (full load)	Voltage	≤1ms	
Fall Time (no load)	Voltage	≤1s	
Fall Time (full load)	Voltage	≤100ms	
Rise Time (Full current)	Current	≤1ms	
Fall Time (Full current)	Current	≤1ms	
Transient Response Time (change from 40% to 90% of rated current)	Voltage	≤200us	
AC Input	Input voltage *3	Three phase +PE	84 kW Max. @180-264V-Input
			168 kW Max. @342-528V-Input
	Maximum Input Current	292A(per phase)@200Vac, 3ø input	
		307A(per phase)@380Vac, 3ø input	

		243A(per phase)@480Vac, 3ø input	
	Maximum Input Apparent Power	181.5kVA	
	Frequency	47Hz~63Hz	
	Power Factor *4	0.99	
Setup Stability-30min	Voltage	≤0.005%+0.005%FS	
	Current	≤0.01%+0.01%FS	
Setup Stability-8h	Voltage	≤0.005%+0.005%FS	
	Current	≤0.01%+0.01%FS	
Readback Stability-30min	Voltage	≤0.005%+0.005%FS	
	Current	≤0.01%+0.01%FS	
Readback Stability-8h	Voltage	≤0.005%+0.005%FS	
	Current	≤0.01%+0.01%FS	
Efficiency		Full current and full power	~93.5%
		Full voltage and full power	~94%
Output Capacitance		2-channel mode	58.4uF/CH
Remote Sense Voltage		1%FS	
Command Response Time		1ms	
Storage Temperature		-10°C~70°C	
Protective Function		OVP, OCP, OPP, UVP, UCP, OTP, Vsense protection	
Standard Interface		Standard: USB, CAN, LAN, Digital IO Optional: GPIB, Analog/RS232), fiber optic socket, EtherCAT card, Relay cards	
Isolation (output to ground)		2250V	
Working Temperature *5		0~50°C	
IP		IP20	
Safety Standard		IEC 61010	
Cooling		Air	
Dimension ( mm)		600mm(W)* 1441.41mm(H)* 840.1mm(D) (Depth 1008.1mm including protective cover)	
Weight( net)		346kg	

\*1. This accuracy specification applies to output power in the range of 10% to 100%. When the output power is low, the resistance deviation ( $\Delta R$ ) can be approximated by:  $\Delta R \approx V / (V/R_{set} - \Delta I) - R_{set}$ . where  $V$  is the external voltage,  $R_{set}$  is the set resistance value, and  $\Delta I$  is the theoretical current deviation of the IT6600.

\*2. This specification was tested under test conditions with an output voltage of  $\geq 30V$ .

\*3. Multi-master cabinet, that is, optional emergency stop module (including AC contactor) models, the standard AC input voltage only supports 380VAC  $\pm 10\%$ , such as the need for 480VAC  $\pm 10\%$  voltage need to be customized.

\*4. Power factor of 0.99 at 50% of rated power and above at nominal input.

\*5. When the unit temperature exceeds 40°C, the rated current and power decrease by 3% for every 1°C increase. When the cabinet temperature exceeds 30°C, they decrease by 2% for every 1°C increase. Both are applicable up to a maximum of 50°C.

**IT66210D-2250-500**

Parameter		IT66210D-2250-500	
Rated value	Voltage	Series mode	0 ~ 2250V
		2-channel mode/Parallel mode	0 ~ 1200V
	Current	Parallel mode	0 ~ 500A
		2-channel mode/Series mode	0 ~ 250A
	Power	Each channel	0 ~ 105kW
		Total	0 ~ 210kW
	Resistance in series (CV priority)	2-channel mode	0 ~ 0.48Ω
		Parallel mode	0 ~ 0.24Ω
		Series mode	0 ~ 0.9Ω
Load resistance (CC priority)	2-channel mode	0.019 ~ 7500Ω	
	Parallel mode	0.01 ~ 7500Ω	
	Series mode	0.037 ~ 7500Ω	
Line Regulation	Voltage	≤0.01%FS	
	Current	≤0.01%FS	
Load Regulation	Voltage	≤0.01%FS	
	Current	≤0.02%FS	
Setup Resolution	Voltage	0.001V	
	Current	0.01A	
	Power	0.001kW	
	Resistance	0.001Ω	
Read Back Resolution	Voltage	0.001V	
	Current	0.01A	
	Power	0.001kW	
Setup Accuracy	Voltage	≤0.02%+0.02%FS	
	Current	≤0.03% + 0.03%FS	
	Power	≤0.05% + 0.15%FS	
	Resistance *1	≥0.5%	
Read Back Accuracy	Voltage	≤0.02%+0.02%FS	
	Current	≤0.03% + 0.03%FS	
	Power	≤0.05% + 0.15%FS	
	Resistance *1	≥0.5%	
Ripple *2	Vpp	20Hz-20MHz	≤0.14%FS
	Vrms	20Hz-20MHz	≤0.028%FS
	Irms	20Hz-300KHz	≤0.14%FS
Setup Temperature Coefficient	Voltage	≤15PPM/°C	
	Current	≤30PPM/°C	
Read Back Temperature Coefficient	Voltage	≤15PPM/°C	
	Current	≤30PPM/°C	
Rise Time (no load)	Voltage	≤2ms	
Rise Time (full load)	Voltage	≤2ms	
Fall Time (no load)	Voltage	≤1s	
Fall Time (full load)	Voltage	≤200ms	
Rise Time (Full current)	Current	≤2ms	

Fall Time (Full current)	Current	≤2ms	
Transient Response Time (change from 40% to 90% of rated current)	Voltage	≤1ms	
AC Input	Input voltage *3	Three phase +PE	105 kW Max. @180-264V-Input 210 kW Max. @342-528V-Input
	Maximum Input Current	364A(per phase)@200Vac, 3ø input	
		383A(per phase)@380Vac, 3ø input	
		304A(per phase)@480Vac, 3ø input	
	Maximum Input Apparent Power	226.9kVA	
	Frequency	47Hz~63Hz	
Power Factor *4	0.99		
Setup Stability-30min	Voltage	≤0.01%+0.01%FS	
	Current	≤0.02%+0.02%FS	
Setup Stability-8h	Voltage	≤0.01%+0.01%FS	
	Current	≤0.02%+0.02%FS	
Readback Stability-30min	Voltage	≤0.01%+0.01%FS	
	Current	≤0.02%+0.02%FS	
Readback Stability-8h	Voltage	≤0.01%+0.01%FS	
	Current	≤0.02%+0.02%FS	
Efficiency	Full current and full power	~93.5%	
	Full voltage and full power	~94%	
Output Capacitance	2-channel mode	73uF/CH	
Remote Sense Voltage	1%FS		
Command Response Time	1ms		
Storage Temperature	-10°C~70°C		
Protective Function	OVP, OCP, OPP, UVP, UCP, OTP, Vsense protection		
Standard Interface	Standard: USB, CAN, LAN, Digital IO Optional: GPIB, Analog/RS232), fiber optic socket, EtherCAT card, Relay cards		
Isolation (output to ground)	2250V		
Working Temperature *5	0~50°C		
IP	IP20		
Safety Standard	IEC 61010		
Cooling	Air		
Dimension ( mm)	600mm(W)* 1441.41mm(H)* 840.1mm(D) (Depth 1008.1mm including protective cover)		
Weight( net)	397kg		

\*1. This accuracy specification applies to output power in the range of 10% to 100%. When the output power is low, the resistance deviation ( $\Delta R$ ) can be approximated by:  $\Delta R \approx V / (V/R_{set} - \Delta I) - R_{set}$ . where  $V$  is the external voltage,  $R_{set}$  is the set resistance value, and  $\Delta I$  is the theoretical current deviation of the IT6600.

\*2. This specification was tested under test conditions with an output voltage of  $\geq 30V$ .

\*3. Multi-master cabinet, that is, optional emergency stop module (including AC contactor) models, the standard AC input voltage only supports 380VAC  $\pm 10\%$ , such as the need for 480VAC  $\pm 10\%$  voltage need to be customized.

\*4. Power factor of 0.99 at 50% of rated power and above at nominal input.

\*5. When the unit temperature exceeds 40°C, the rated current and power decrease by 3% for every 1°C increase. When the cabinet temperature exceeds 30°C, they decrease by 2% for every 1°C increase. Both are applicable up to a maximum of 50°C.

## IT66252D-2250-600

Parameter		IT66252D-2250-600	
Rated value	Voltage	Series mode	0 ~ 2250V
		2-channel mode/Parallel mode	0 ~ 1200V
	Current	Parallel mode	0 ~ 600A
		2-channel mode/Series mode	0 ~ 300A
	Power	Each channel	0 ~ 126kW
		Total	0 ~ 252kW
	Resistance in series (CV priority)	2-channel mode	0 ~ 0.4Ω
		Parallel mode	0 ~ 0.2Ω
		Series mode	0 ~ 0.75Ω
	Load resistance (CC priority)	2-channel mode	0.016 ~ 7500Ω
Parallel mode		0.008 ~ 7500Ω	
Series mode		0.031 ~ 7500Ω	
Line Regulation	Voltage	≤0.01%FS	
	Current	≤0.01%FS	
Load Regulation	Voltage	≤0.01%FS	
	Current	≤0.02%FS	
Setup Resolution	Voltage	0.001V	
	Current	0.01A	
	Power	0.001kW	
	Resistance	0.001Ω	
Read Back Resolution	Voltage	0.001V	
	Current	0.01A	
	Power	0.001kW	
Setup Accuracy	Voltage	≤0.02%+0.02%FS	
	Current	≤0.03% + 0.03%FS	
	Power	≤0.05% + 0.15%FS	
	Resistance *1	≥0.5%	
Read Back Accuracy	Voltage	≤0.02%+0.02%FS	
	Current	≤0.03% + 0.03%FS	
	Power	≤0.05% + 0.15%FS	
	Resistance *1	≥0.5%	
Ripple *2	Vpp	20Hz-20MHz	≤0.15%FS
	Vrms	20Hz-20MHz	≤0.03%FS
	Irms	20Hz-300KHz	≤0.15%FS
Setup Temperature Coefficient	Voltage	≤15PPM/°C	
	Current	≤30PPM/°C	
Read Back Temperature Coefficient	Voltage	≤15PPM/°C	
	Current	≤30PPM/°C	
Rise Time (no load)	Voltage	≤2ms	

Rise Time (full load)	Voltage	≤2ms	
Fall Time (no load)	Voltage	≤1s	
Fall Time (full load)	Voltage	≤200ms	
Rise Time (Full current)	Current	≤2ms	
Fall Time (Full current)	Current	≤2ms	
Transient Response Time (change from 40% to 90% of rated current)	Voltage	≤1ms	
AC Input	Input voltage *3	Three phase +PE	126 kW Max. @180-264V-Input
			252 kW Max. @342-528V-Input
	Maximum Input Current	437A(per phase)@200Vac, 3ø input	
		460A(per phase)@380Vac, 3ø input	
		364A(per phase)@480Vac, 3ø input	
	Maximum Input Apparent Power	272.3kVA	
Frequency	47Hz~63Hz		
Power Factor *4	0.99		
Setup Stability-30min	Voltage	≤0.01%+0.01%FS	
	Current	≤0.02%+0.02%FS	
Setup Stability-8h	Voltage	≤0.01%+0.01%FS	
	Current	≤0.02%+0.02%FS	
Readback Stability-30min	Voltage	≤0.01%+0.01%FS	
	Current	≤0.02%+0.02%FS	
Readback Stability-8h	Voltage	≤0.01%+0.01%FS	
	Current	≤0.02%+0.02%FS	
Efficiency	Full current and full power	~93.5%	
	Full voltage and full power	~94%	
Output Capacitance	2-channel mode	87.6uF/CH	
Remote Sense Voltage	1%FS		
Command Response Time	1ms		
Storage Temperature	-10℃~70℃		
Protective Function	OVP, OCP, OPP, UVP, UCP, OTP, Vsense protection		
Standard Interface	Standard: USB, CAN, LAN, Digital IO Optional: GPIB, Analog/RS232), fiber optic socket, EtherCAT card, Relay cards		
Isolation (output to ground)	2250V		
Working Temperature *5	0~50℃		
IP	IP20		
Safety Standard	IEC 61010		
Cooling	Air		
Dimension ( mm)	600mm(W)* 1441.41mm(H)* 840.1mm(D) (Depth 1008.1mm including protective cover)		
Weight( net)	447kg		

\*1. This accuracy specification applies to output power in the range of 10% to 100%. When the output power is low, the resistance deviation ( $\Delta R$ ) can be approximated by:  $\Delta R \approx V / (V/R_{set} - \Delta I) - R_{set}$ . where  $V$  is the external voltage,  $R_{set}$  is the set resistance value, and  $\Delta I$  is the theoretical current deviation of the IT6600.

\*2. This specification was tested under test conditions with an output voltage of  $\geq 30V$ .

\*3. Multi-master cabinet, that is, optional emergency stop module (including AC contactor) models, the standard AC input voltage only supports 380VAC  $\pm$  10%, such as the need for 480VAC  $\pm$  10% voltage need to be customized.

\*4. Power factor of 0.99 at 50% of rated power and above at nominal input.

\*5. When the unit temperature exceeds 40°C, the rated current and power decrease by 3% for every 1°C increase. When the cabinet temperature exceeds 30°C, they decrease by 2% for every 1°C increase. Both are applicable up to a maximum of 50°C.

## IT66294D-2250-700

Parameter		IT66294D-2250-700	
Rated value	Voltage	Series mode	0 ~ 2250V
		2-channel mode/Parallel mode	0 ~ 1200V
	Current	Parallel mode	0 ~ 700A
		2-channel mode/Series mode	0 ~ 350A
	Power	Each channel	0 ~ 147kW
		Total	0 ~ 294kW
	Resistance in series (CV priority)	2-channel mode	0 ~ 0.343Ω
		Parallel mode	0 ~ 0.172Ω
		Series mode	0 ~ 0.643Ω
Load resistance (CC priority)	2-channel mode	0.014 ~ 7500Ω	
	Parallel mode	0.007 ~ 7500Ω	
	Series mode	0.027 ~ 7500Ω	
Line Regulation	Voltage	$\leq 0.01\%FS$	
	Current	$\leq 0.01\%FS$	
Load Regulation	Voltage	$\leq 0.01\%FS$	
	Current	$\leq 0.02\%FS$	
Setup Resolution	Voltage	0.001V	
	Current	0.01A	
	Power	0.001kW	
	Resistance	0.001Ω	
Read Back Resolution	Voltage	0.001V	
	Current	0.01A	
	Power	0.001kW	
Setup Accuracy	Voltage	$\leq 0.02\% + 0.02\%FS$	
	Current	$\leq 0.03\% + 0.03\%FS$	
	Power	$\leq 0.05\% + 0.15\%FS$	
	Resistance *1	$\geq 0.5\%$	
Read Back Accuracy	Voltage	$\leq 0.02\% + 0.02\%FS$	
	Current	$\leq 0.03\% + 0.03\%FS$	
	Power	$\leq 0.05\% + 0.15\%FS$	
	Resistance *1	$\geq 0.5\%$	
Ripple *2	Vpp	20Hz-20MHz	$\leq 0.16\%FS$
	Vrms	20Hz-20MHz	$\leq 0.032\%FS$
	Irms	20Hz-300KHz	$\leq 0.16\%FS$
Setup Temperature	Voltage	$\leq 15PPM/^{\circ}C$	

Coefficient	Current	$\leq 30\text{PPM}/^{\circ}\text{C}$	
Read Back Temperature Coefficient	Voltage	$\leq 15\text{PPM}/^{\circ}\text{C}$	
	Current	$\leq 30\text{PPM}/^{\circ}\text{C}$	
Rise Time (no load)	Voltage	$\leq 2\text{ms}$	
Rise Time (full load)	Voltage	$\leq 2\text{ms}$	
Fall Time (no load)	Voltage	$\leq 1\text{s}$	
Fall Time (full load)	Voltage	$\leq 200\text{ms}$	
Rise Time (Full current)	Current	$\leq 2\text{ms}$	
Fall Time (Full current)	Current	$\leq 2\text{ms}$	
Transient Response Time (change from 40% to 90% of rated current)	Voltage	$\leq 1\text{ms}$	
AC Input	Input voltage *3	Three phase +PE	147 kW Max. @180-264V-Input 294 kW Max. @342-528V-Input
		Maximum Input Current	
	510A(per phase)@200Vac, 3 $\phi$ input		
	537A(per phase)@380Vac, 3 $\phi$ input		
	425A(per phase)@480Vac, 3 $\phi$ input		
	Maximum Input Apparent Power		317.7kVA
Frequency		47Hz~63Hz	
Power Factor *4		0.99	
Setup Stability-30min	Voltage	$\leq 0.01\%+0.01\%\text{FS}$	
	Current	$\leq 0.02\%+0.02\%\text{FS}$	
Setup Stability-8h	Voltage	$\leq 0.01\%+0.01\%\text{FS}$	
	Current	$\leq 0.02\%+0.02\%\text{FS}$	
Readback Stability-30min	Voltage	$\leq 0.01\%+0.01\%\text{FS}$	
	Current	$\leq 0.02\%+0.02\%\text{FS}$	
Readback Stability-8h	Voltage	$\leq 0.01\%+0.01\%\text{FS}$	
	Current	$\leq 0.02\%+0.02\%\text{FS}$	
Efficiency		Full current and full power	$\sim 93.5\%$
		Full voltage and full power	$\sim 94\%$
Output Capacitance	2-channel mode	102.2 $\mu\text{F}/\text{CH}$	
Remote Sense Voltage	1%FS		
Command Response Time	1ms		
Storage Temperature	$-10^{\circ}\text{C} \sim 70^{\circ}\text{C}$		
Protective Function	OVP, OCP, OPP, UVP, UCP, OTP, Vsense protection		
Standard Interface	Standard: USB, CAN, LAN, Digital IO Optional: GPIB, Analog/RS232), fiber optic socket, EtherCAT card, Relay cards		
Isolation (output to ground)	2250V		
Working Temperature *5	$0 \sim 50^{\circ}\text{C}$		
IP	IP20		
Safety Standard	IEC 61010		
Cooling	Air		
Dimension ( mm)	600mm(W)* 1441.41mm(H)* 840.1mm(D) (Depth 1008.1mm including protective cover)		
Weight( net)	497kg		

\*1. This accuracy specification applies to output power in the range of 10% to 100%. When the

output power is low, the resistance deviation ( $\Delta R$ ) can be approximated by:  $\Delta R \approx V / (V/R_{set} - \Delta I) - R_{set}$ . where  $V$  is the external voltage,  $R_{set}$  is the set resistance value, and  $\Delta I$  is the theoretical current deviation of the IT6600.

\*2. This specification was tested under test conditions with an output voltage of  $\geq 30V$ .

\*3. Multi-master cabinet, that is, optional emergency stop module (including AC contactor) models, the standard AC input voltage only supports  $380VAC \pm 10\%$ , such as the need for  $480VAC \pm 10\%$  voltage need to be customized.

\*4. Power factor of 0.99 at 50% of rated power and above at nominal input.

\*5. When the unit temperature exceeds  $40^{\circ}C$ , the rated current and power decrease by 3% for every  $1^{\circ}C$  increase. When the cabinet temperature exceeds  $30^{\circ}C$ , they decrease by 2% for every  $1^{\circ}C$  increase. Both are applicable up to a maximum of  $50^{\circ}C$ .

## IT66336D-2250-800

Parameter		IT66336D-2250-800	
Rated value	Voltage	Series mode	0 ~ 2250V
		2-channel mode/Parallel mode	0 ~ 1200V
	Current	Parallel mode	0 ~ 800A
		2-channel mode/Series mode	0 ~ 400A
	Power	Each channel	0 ~ 168kW
		Total	0 ~ 336kW
	Resistance in series (CV priority)	2-channel mode	0 ~ 0.3 $\Omega$
		Parallel mode	0 ~ 0.15 $\Omega$
		Series mode	0 ~ 0.563 $\Omega$
	Load resistance (CC priority)	2-channel mode	0.012 ~ 7500 $\Omega$
Parallel mode		0.006 ~ 7500 $\Omega$	
Series mode		0.023 ~ 7500 $\Omega$	
Line Regulation	Voltage	$\leq 0.01\%FS$	
	Current	$\leq 0.01\%FS$	
Load Regulation	Voltage	$\leq 0.01\%FS$	
	Current	$\leq 0.02\%FS$	
Setup Resolution	Voltage	0.001V	
	Current	0.01A	
	Power	0.001kW	
	Resistance	0.001 $\Omega$	
Read Back Resolution	Voltage	0.001V	
	Current	0.01A	
	Power	0.001kW	
Setup Accuracy	Voltage	$\leq 0.02\% + 0.02\%FS$	
	Current	$\leq 0.03\% + 0.03\%FS$	
	Power	$\leq 0.05\% + 0.15\%FS$	
	Resistance *1	$\geq 0.5\%$	
Read Back Accuracy	Voltage	$\leq 0.02\% + 0.02\%FS$	
	Current	$\leq 0.03\% + 0.03\%FS$	
	Power	$\leq 0.05\% + 0.15\%FS$	
	Resistance *1	$\geq 0.5\%$	

Ripple *2	Vpp	20Hz-20MHz	≤0.17%FS
	Vrms	20Hz-20MHz	≤0.034%FS
	Irms	20Hz-300KHz	≤0.17%FS
Setup Temperature Coefficient	Voltage	≤15PPM/°C	
	Current	≤30PPM/°C	
Read Back Temperature Coefficient	Voltage	≤15PPM/°C	
	Current	≤30PPM/°C	
Rise Time (no load)	Voltage	≤2ms	
Rise Time (full load)	Voltage	≤2ms	
Fall Time (no load)	Voltage	≤1s	
Fall Time (full load)	Voltage	≤200ms	
Rise Time (Full current)	Current	≤2ms	
Fall Time (Full current)	Current	≤2ms	
Transient Response Time (change from 40% to 90% of rated current)	Voltage	≤1ms	
AC Input	Input voltage *3	Three phase +PE	168 kW Max. @180-264V-Input
			336 kW Max. @342-528V-Input
	Maximum Input Current	583A(per phase)@200Vac, 3ø input	
		613A(per phase)@380Vac, 3ø input	
		486A(per phase)@480Vac, 3ø input	
	Maximum Input Apparent Power	363kVA	
Frequency	47Hz~63Hz		
Power Factor *4	0.99		
Setup Stability-30min	Voltage	≤0.01%+0.01%FS	
	Current	≤0.02%+0.02%FS	
Setup Stability-8h	Voltage	≤0.01%+0.01%FS	
	Current	≤0.02%+0.02%FS	
Readback Stability-30min	Voltage	≤0.01%+0.01%FS	
	Current	≤0.02%+0.02%FS	
Readback Stability-8h	Voltage	≤0.01%+0.01%FS	
	Current	≤0.02%+0.02%FS	
Efficiency	Full current and full power	~93.5%	
	Full voltage and full power	~94%	
Output Capacitance	2-channel mode	116.8uF/CH	
Remote Sense Voltage	1%FS		
Command Response Time	1ms		
Storage Temperature	-10°C~70°C		
Protective Function	OVP, OCP, OPP, UVP, UCP, OTP, Vsense protection		
Standard Interface	Standard: USB, CAN, LAN, Digital IO Optional: GPIB, Analog/RS232), fiber optic socket, EtherCAT card, Relay cards		
Isolation (output to ground)	2250V		
Working Temperature *5	0~50°C		
IP	IP20		
Safety Standard	IEC 61010		
Cooling	Air		

Dimension ( mm)	600mm(W)* 1885.91mm(H)* 840.1mm(D) (Depth 1008.1mm including protective cover)
Weight( net)	583kg

\*1. This accuracy specification applies to output power in the range of 10% to 100%. When the output power is low, the resistance deviation ( $\Delta R$ ) can be approximated by:  $\Delta R \approx V / (V/R_{set} - \Delta I) - R_{set}$ . where  $V$  is the external voltage,  $R_{set}$  is the set resistance value, and  $\Delta I$  is the theoretical current deviation of the IT6600.

\*2. This specification was tested under test conditions with an output voltage of  $\geq 30V$ .

\*3. Multi-master cabinet, that is, optional emergency stop module (including AC contactor) models, the standard AC input voltage only supports 380VAC  $\pm 10\%$ , such as the need for 480VAC  $\pm 10\%$  voltage need to be customized.

\*4. Power factor of 0.99 at 50% of rated power and above at nominal input.

\*5. When the unit temperature exceeds 40°C, the rated current and power decrease by 3% for every 1°C increase. When the cabinet temperature exceeds 30°C, they decrease by 2% for every 1°C increase. Both are applicable up to a maximum of 50°C.

## IT66378D-2250-900

Parameter		IT66378D-2250-900	
Rated value	Voltage	Series mode	0 ~ 2250V
		2-channel mode/Parallel mode	0 ~ 1200V
	Current	Parallel mode	0 ~ 900A
		2-channel mode/Series mode	0 ~ 450A
	Power	Each channel	0 ~ 189kW
		Total	0 ~ 378kW
	Resistance in series (CV priority)	2-channel mode	0 ~ 0.267Ω
		Parallel mode	0 ~ 0.134Ω
		Series mode	0 ~ 0.5Ω
	Load resistance (CC priority)	2-channel mode	0.011 ~ 7500Ω
Parallel mode		0.006 ~ 7500Ω	
Series mode		0.021 ~ 7500Ω	
Line Regulation	Voltage	$\leq 0.01\%FS$	
	Current	$\leq 0.01\%FS$	
Load Regulation	Voltage	$\leq 0.01\%FS$	
	Current	$\leq 0.02\%FS$	
Setup Resolution	Voltage	0.001V	
	Current	0.01A	
	Power	0.001kW	
	Resistance	0.001Ω	
Read Back Resolution	Voltage	0.001V	
	Current	0.01A	
	Power	0.001kW	
Setup Accuracy	Voltage	$\leq 0.02\% + 0.02\%FS$	
	Current	$\leq 0.03\% + 0.03\%FS$	
	Power	$\leq 0.05\% + 0.15\%FS$	
	Resistance *1	$\geq 0.5\%$	

Read Back Accuracy	Voltage	$\leq 0.02\% + 0.02\%FS$	
	Current	$\leq 0.03\% + 0.03\%FS$	
	Power	$\leq 0.05\% + 0.15\%FS$	
	Resistance *1	$\geq 0.5\%$	
Ripple *2	Vpp	20Hz-20MHz	$\leq 0.18\%FS$
	Vrms	20Hz-20MHz	$\leq 0.036\%FS$
	Irms	20Hz-300KHz	$\leq 0.18\%FS$
Setup Temperature Coefficient	Voltage	$\leq 15PPM/^{\circ}C$	
	Current	$\leq 30PPM/^{\circ}C$	
Read Back Temperature Coefficient	Voltage	$\leq 15PPM/^{\circ}C$	
	Current	$\leq 30PPM/^{\circ}C$	
Rise Time (no load)	Voltage	$\leq 2ms$	
Rise Time (full load)	Voltage	$\leq 2ms$	
Fall Time (no load)	Voltage	$\leq 1s$	
Fall Time (full load)	Voltage	$\leq 200ms$	
Rise Time (Full current)	Current	$\leq 2ms$	
Fall Time (Full current)	Current	$\leq 2ms$	
Transient Response Time (change from 40% to 90% of rated current)	Voltage	$\leq 1ms$	
AC Input	Input voltage *3	Three phase +PE	189 kW Max. @180-264V-Input 378 kW Max. @342-528V-Input
		Maximum Input Current	655A(per phase)@200Vac, 3 $\phi$ input
	690A(per phase)@380Vac, 3 $\phi$ input		
	546A(per phase)@480Vac, 3 $\phi$ input		
	Maximum Input Apparent Power	408.4kVA	
	Frequency	47Hz~63Hz	
Power Factor *4	0.99		
Setup Stability-30min	Voltage	$\leq 0.01\% + 0.01\%FS$	
	Current	$\leq 0.02\% + 0.02\%FS$	
Setup Stability-8h	Voltage	$\leq 0.01\% + 0.01\%FS$	
	Current	$\leq 0.02\% + 0.02\%FS$	
Readback Stability-30min	Voltage	$\leq 0.01\% + 0.01\%FS$	
	Current	$\leq 0.02\% + 0.02\%FS$	
Readback Stability-8h	Voltage	$\leq 0.01\% + 0.01\%FS$	
	Current	$\leq 0.02\% + 0.02\%FS$	
Efficiency	Full current and full power	$\sim 93.5\%$	
	Full voltage and full power	$\sim 94\%$	
Output Capacitance	2-channel mode	131.4uF/CH	
Remote Sense Voltage	1%FS		
Command Response Time	1ms		
Storage Temperature	$-10^{\circ}C \sim 70^{\circ}C$		
Protective Function	OVP, OCP, OPP, UVP, UCP, OTP, Vsense protection		
Standard Interface	Standard: USB, CAN, LAN, Digital IO Optional: GPIB, Analog/RS232), fiber optic socket, EtherCAT card, Relay cards		
Isolation (output to ground)	2250V		

Working Temperature *5	0~50℃
IP	IP20
Safety Standard	IEC 61010
Cooling	Air
Dimension ( mm)	600mm(W)* 1885.91mm(H)* 840.1mm(D) (Depth 1008.1mm including protective cover)
Weight( net)	633kg

\*1. This accuracy specification applies to output power in the range of 10% to 100%. When the output power is low, the resistance deviation ( $\Delta R$ ) can be approximated by:  $\Delta R \approx V / (V/R_{set} - \Delta I) - R_{set}$ . where  $V$  is the external voltage,  $R_{set}$  is the set resistance value, and  $\Delta I$  is the theoretical current deviation of the IT6600.

\*2. This specification was tested under test conditions with an output voltage of  $\geq 30V$ .

\*3. Multi-master cabinet, that is, optional emergency stop module (including AC contactor) models, the standard AC input voltage only supports 380VAC  $\pm 10\%$ , such as the need for 480VAC  $\pm 10\%$  voltage need to be customized.

\*4. Power factor of 0.99 at 50% of rated power and above at nominal input.

\*5. When the unit temperature exceeds 40℃, the rated current and power decrease by 3% for every 1℃ increase. When the cabinet temperature exceeds 30℃, they decrease by 2% for every 1℃ increase. Both are applicable up to a maximum of 50℃.

## IT66420D-2250-1000

Parameter		IT66420D-2250-1000	
Rated value	Voltage	Series mode	0 ~ 2250V
		2-channel mode/Parallel mode	0 ~ 1200V
	Current	Parallel mode	0 ~ 1000A
		2-channel mode/Series mode	0 ~ 500A
	Power	Each channel	0 ~ 210kW
		Total	0 ~ 420kW
	Resistance in series (CV priority)	2-channel mode	0 ~ 0.24Ω
		Parallel mode	0 ~ 0.12Ω
		Series mode	0 ~ 0.45Ω
	Load resistance (CC priority)	2-channel mode	0.01 ~ 7500Ω
Parallel mode		0.005 ~ 7500Ω	
Series mode		0.019 ~ 7500Ω	
Line Regulation	Voltage	$\leq 0.01\%FS$	
	Current	$\leq 0.01\%FS$	
Load Regulation	Voltage	$\leq 0.01\%FS$	
	Current	$\leq 0.02\%FS$	
Setup Resolution	Voltage	0.001V	
	Current	0.01A	
	Power	0.001kW	
	Resistance	0.001Ω	
Read Back Resolution	Voltage	0.001V	
	Current	0.01A	
	Power	0.001kW	
Setup Accuracy	Voltage	$\leq 0.02\%+0.02\%FS$	

	Current	$\leq 0.03\% + 0.03\%FS$	
	Power	$\leq 0.05\% + 0.15\%FS$	
	Resistance *1	$\geq 0.5\%$	
Read Back Accuracy	Voltage	$\leq 0.02\% + 0.02\%FS$	
	Current	$\leq 0.03\% + 0.03\%FS$	
	Power	$\leq 0.05\% + 0.15\%FS$	
	Resistance *1	$\geq 0.5\%$	
Ripple *2	Vpp	20Hz-20MHz	$\leq 0.19\%FS$
	Vrms	20Hz-20MHz	$\leq 0.038\%FS$
	Irms	20Hz-300KHz	$\leq 0.19\%FS$
Setup Temperature Coefficient	Voltage	$\leq 15PPM/^{\circ}C$	
	Current	$\leq 30PPM/^{\circ}C$	
Read Back Temperature Coefficient	Voltage	$\leq 15PPM/^{\circ}C$	
	Current	$\leq 30PPM/^{\circ}C$	
Rise Time (no load)	Voltage	$\leq 2ms$	
Rise Time (full load)	Voltage	$\leq 2ms$	
Fall Time (no load)	Voltage	$\leq 1s$	
Fall Time (full load)	Voltage	$\leq 200ms$	
Rise Time (Full current)	Current	$\leq 2ms$	
Fall Time (Full current)	Current	$\leq 2ms$	
Transient Response Time (change from 40% to 90% of rated current)	Voltage	$\leq 1ms$	
AC Input	Input voltage *3	Three phase +PE	210 kW Max. @180-264V-Input 420 kW Max. @342-528V-Input
		Maximum Input Current	728A(per phase)@200Vac, 3 $\phi$ input 766A(per phase)@380Vac, 3 $\phi$ input 607A(per phase)@480Vac, 3 $\phi$ input
	Maximum Input Apparent Power	453.8kVA	
	Frequency	47Hz~63Hz	
	Power Factor *4	0.99	
	Setup Stability-30min	Voltage	$\leq 0.01\% + 0.01\%FS$
Current		$\leq 0.02\% + 0.02\%FS$	
Setup Stability-8h	Voltage	$\leq 0.01\% + 0.01\%FS$	
	Current	$\leq 0.02\% + 0.02\%FS$	
Readback Stability-30min	Voltage	$\leq 0.01\% + 0.01\%FS$	
	Current	$\leq 0.02\% + 0.02\%FS$	
Readback Stability-8h	Voltage	$\leq 0.01\% + 0.01\%FS$	
	Current	$\leq 0.02\% + 0.02\%FS$	
Efficiency	Full current and full power	$\sim 93.5\%$	
	Full voltage and full power	$\sim 94\%$	
Output Capacitance	2-channel mode	146uF/CH	
Remote Sense Voltage	1%FS		
Command Response Time	1ms		
Storage Temperature	$-10^{\circ}C \sim 70^{\circ}C$		
Protective Function	OVP, OCP, OPP, UVP, UCP, OTP, Vsense protection		

Standard Interface	Standard: USB, CAN, LAN, Digital IO Optional: GPIB, Analog/RS232), fiber optic socket, EtherCAT card, Relay cards
Isolation (output to ground)	2250V
Working Temperature *5	0~50°C
IP	IP20
Safety Standard	IEC 61010
Cooling	Air
Dimension ( mm)	600mm(W)* 1885.91mm(H)* 840.1mm(D) (Depth 1008.1mm including protective cover)
Weight( net)	683kg

\*1. This accuracy specification applies to output power in the range of 10% to 100%. When the output power is low, the resistance deviation ( $\Delta R$ ) can be approximated by:  $\Delta R \approx V / (V/R_{set} - \Delta I) - R_{set}$ . where  $V$  is the external voltage,  $R_{set}$  is the set resistance value, and  $\Delta I$  is the theoretical current deviation of the IT6600.

\*2. This specification was tested under test conditions with an output voltage of  $\geq 30V$ .

\*3. Multi-master cabinet, that is, optional emergency stop module (including AC contactor) models, the standard AC input voltage only supports 380VAC  $\pm 10\%$ , such as the need for 480VAC  $\pm 10\%$  voltage need to be customized.

\*4. Power factor of 0.99 at 50% of rated power and above at nominal input.

\*5. When the unit temperature exceeds 40°C, the rated current and power decrease by 3% for every 1°C increase. When the cabinet temperature exceeds 30°C, they decrease by 2% for every 1°C increase. Both are applicable up to a maximum of 50°C.

All the above parameters are subject to change without prior notice from ITECH.

---

## Chapter8 Remote Control

---

This series power supply comes standard with three communication interfaces: USB, LAN and CAN, and supports two optional communication interfaces: GPIB, RS232. You can choose one of them to communicate with your computer.

When you use the remote interface to send SCPI instructions, if you use the programming commands that involve modifying the instrument settings, such as modifying the output voltage value, after completing the communication connection between the instrument and the host computer, and after the communication settings are completed, you must execute the **SYST:REM** command firstly.

### 8.1 USB Interface

The USB interface is located on the rear panel of the instrument. You can connect the instrument to the computer via a cable with a USB interface on both ends (USB A-type connector on one end and USB B-type connector on the other).

#### Operation step

The operation steps to change the USB interface type in System Menu are as follows.

1. Press the composite keys [**Shift**] + [**P-set**] (System) on the front panel to enter the system menu.
2. Select Communication ->**USB** and press [**Enter**].
3. Select **USB Type** to Device, and press [**Enter**].
4. Select the USB device class to TMC or VCP, and press [**Enter**].

### 8.2 LAN Interface

When the user connect PC through LAN interface, the following is required to use the LAN interface. The LAN interface complies with the LXI standard.

#### Connect Interface

Use the following steps to quickly connect your instrument to your LAN and configure it. Two typical LAN interface systems are described below: private LAN and site LAN.

- Connect to the private LAN

A private LAN is a network in which LAN-enabled instruments and computers are directly connected. They are typically small, with no centrally-managed resources. When connected to a computer, a standard network cable can be used to connect directly to the computer via the LAN interface.

- Connect to the site LAN

A site LAN is a local area network in which LAN-enabled instruments and computers are connected to the network through routers, hubs, and/or switches. They are typically large, centrally-managed networks with

services such as DHCP and DNS servers. When connected to a computer, a network cable can be used to connect to the router, and the computer is also connected to the router.



### Note

- When using one crossover cable to connect PC directly, the gateway address of the instrument should be consistent with that of the PC, and the IP address should be at the same network segment with the PC's IP address.
- When the instrument and computer are connected to the router, an independent IP address must be assigned for the instrument.

## Configure LAN Interface Information

The configurable parameters of the IT6600 series power supply are described as follows.

### LAN Config:

- **Mode:** IP Address setting method, user can select automatically configure the address of the instrument (DHCP) or manually.
- **IP:** This value is the Internet Protocol (IP) address of the instrument. An IP address is required for all IP and TCP/IP communications with the instrument. An IP Address consists of 4 decimal numbers separated by periods. Each decimal number ranges from 0 through 255 with no leading zeros (for example, 169.254.2.20).
- **Mask:** This value is used to enable the instrument to determine if a client IP address is on the same local subnet. The same numbering notation applies as for the IP Address. When a client IP address is on a different subnet, all packets must be sent to the Default Gateway.
- **Gateway:** This value is the IP Address of the default gateway that allows the instrument to communicate with systems that are not on the local subnet, as determined by the subnet mask setting. The same numbering notation applies as for the IP Address.
- **Socket Port:** This value indicates the port number corresponding to the service.

### How to Configure

Take manual configuration as an example. The steps are as follows:

1. Press the composite keys **[Shift] + [P-set]** (System) on the front panel to enter the system menu.
2. Select **Communication** and press **[Enter]**.
3. Press the Left/Right key to select **LAN** and set the mode to **Manual**.
4. Set the **IP**, **Mask** and the other parameters in turns, and press **[Enter]**.

### 8.2.1 Using Web Server

The instrument provides a built-in web server, allowing you to monitor it directly from your computer's web browser. To use this web server, connect the instrument and the computer via the LAN interface. Then, enter the instrument's IP address in the address bar at the top of the computer's web browser to access front panel control, including LAN configuration parameters.

The address format to be entered in the browser's address bar is: `http://192.168.200.100`.

192.168.200.100 is the default IP address. If it has been changed by the user, replace this IP with the actual configuration found in the instrument's Menu.

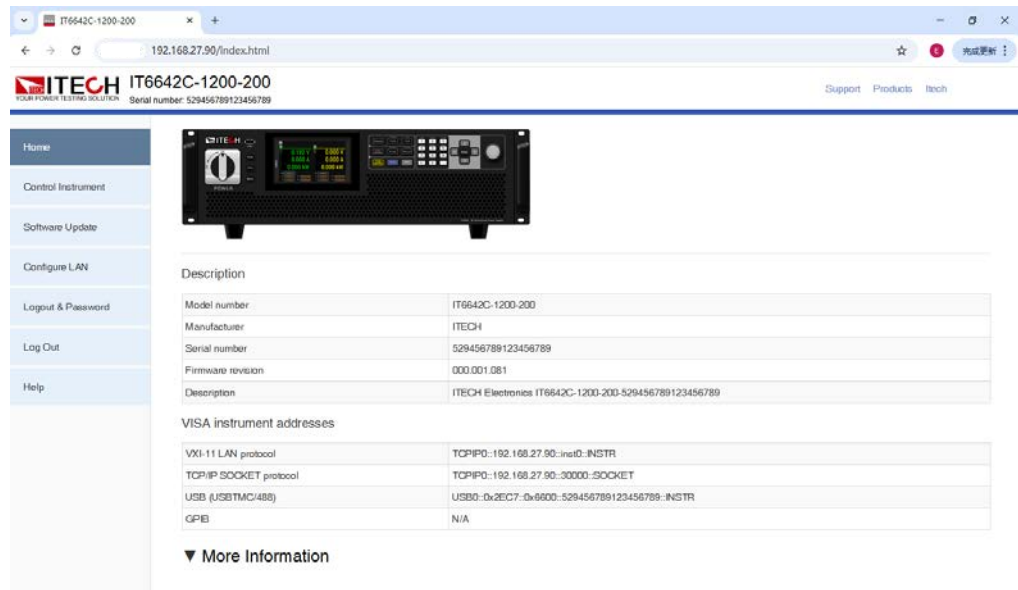

You can select different pages by clicking the buttons shown in the navigation bar on the left side of the window. The detailed descriptions are as follows.

- **Home:** The main web interface that displays the instrument model, appearance image, and key information including Description, VISA instrument addresses, and LAN details.
- **Control Instrument:** Enables the Web control to begin controlling the instrument. This page allows you to monitor and control the instrument. The initial login password is itech.
- **Software Update:** Performs a system upgrade.  
Click [Click here](#), to select the system upgrade installation package (for example, IT6600-U-VXXX.itech), and then click **Update** performs the upgrade operation. After the upgrade is complete, the instrument needs to be restarted.
- **Configure LAN:** Reconfigure the LAN parameters.
- **Password:** Modify the login password for the Control Instrument and Software Update pages to control access to the Web interface.
- **Logout:** logout the Web interface.
- **Help:** Detailed instructions for using the Web features.

## 8.2.2 Using Telnet

The Telnet utility (as well as sockets), is another way to communicate with the instrument without using I/O libraries or drivers. In all cases, you must first establish a LAN connection from your computer to the instrument as previously described.

In an MS-DOS Command Prompt box, type “telnet hostname” where hostname is the instrument’s hostname or IP address. Press the Enter key and you should get a Telnet session box with a title indicating that you are connected to the

instrument and 23 is the instrument's telnet port. Type the SCPI commands at the prompt.

### 8.2.3 Using Sockets

#### CAUTION

- **Before using this function, you need to configure Socket Port, and the configuration on the instrument side should be consistent with the configuration on the PC side.**
- **The instruments allow any combination of up to six simultaneous socket and telnet connections to be made.**

ITECH instruments have SCPI socket services, which can be used to send and receive SCPI commands, queries, and query responses. All commands must be terminated with a newline for the message to be parsed. All query responses will also be terminated with a newline.

### 8.2.4 Using VNC

VNC (Virtual Network Computing) is a method of controlling a machine from a remote desktop. Before using VNC, make sure to connect the machine and computer using a LAN connection and configure the machine's IP address to ensure they are on the same LAN.

#### Using the Browser

Enter the IP address of the machine + port number in the address bar of your browser and press enter to connect to the machine. Note that the port number must be 5800. The opened page is displayed as follows:

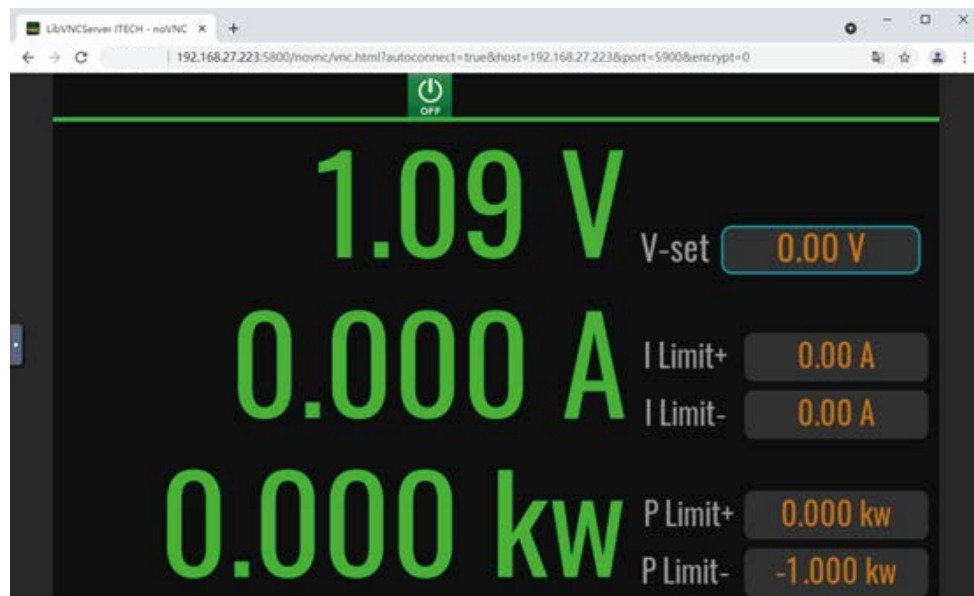

#### Using the VNC Client

1. Double-click the VNC client software.

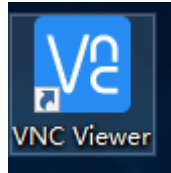

2. In the software that opens, enter the IP address of the machine in the edit box and press enter to connect to access the machine.

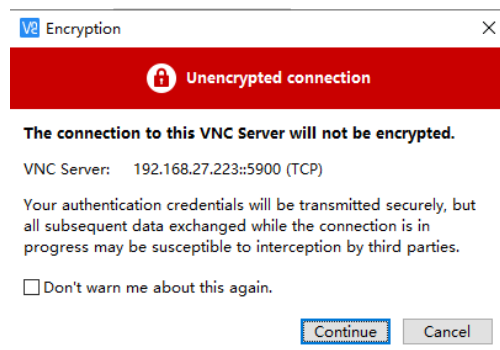
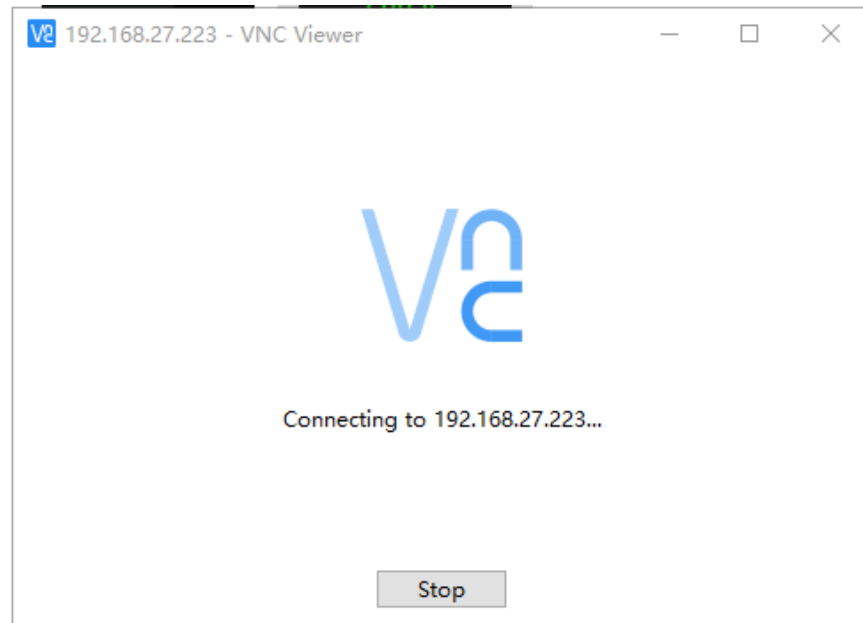
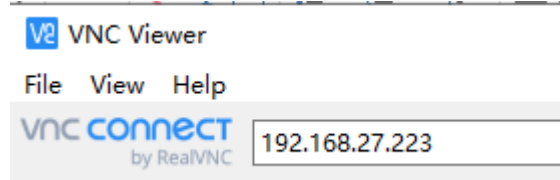

3. Click [Continue] to display the machine touch screen.



### 8.3 CAN Interface

The CAN interface is located on the rear panel of the instrument and is connected to the computer using a CAN communication cable. The definition of CAN pins are as follows.

Pins	Description
H	CAN_H
L	CAN_L

### CAN Configuration

The user needs to configure the CAN interface parameters in the system menu before using the remote control. The CAN interface parameters are as follows.

Name	Description
Baud rate	Select the baud rate from the following options: 5k/10k/20k/40k/50k/80k/100k/125k/200k/250k/400k/500k/600k/800k/1000k.
Address	Range: 0 – 127.
Protocol	<ul style="list-style-type: none"> <li>● CAN_OPEN: High-level protocol for the CAN bus.</li> <li>● CAN2.0: ITECH CAN version 2.0 protocol.</li> </ul>

The operation steps are as follows.

1. Press the composite keys [**Shift**] + [**P-set**] (System) on the front panel to enter the system menu.
2. Select **Communication** and press [**Enter**].
3. Select **CAN** and press [**Enter**].
4. Set the baud rate and address, press [**Enter**].

## CAN Troubleshooting

If you meet some problems when communicating with PC by CAN interface, please check the following items:

- PC and the instrument must have the same baud rate.
  - Ensure you have used the correct communication cable (CAN\_H, CAN\_L). Please pay attention that some cable may not have a correct internal wiring even it is with an appropriate plug.
  - The interface cable is correctly connected (CAN\_H to CAN\_H, CAN\_L to CAN\_L).
  - If the communication signal is poor or unstable, it is recommended to connect a 120  $\Omega$  terminating resistance.
- The connection diagram of a single device is as below.

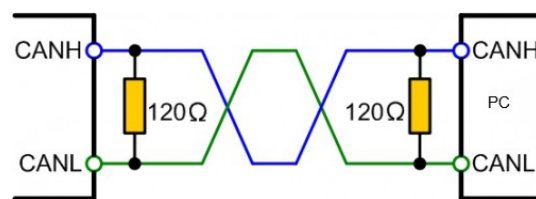

- The connection diagram of multiple devices is as below.

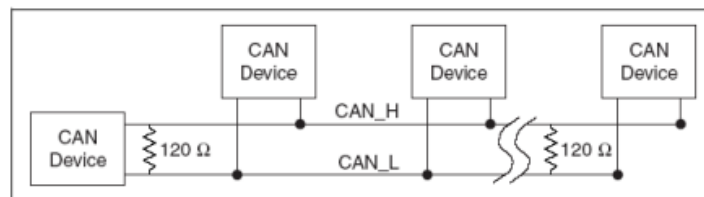

## 8.4 GPIB Interface (Optional)

The GPIB (IEEE-488) interface is assembled in the IT-E176 communication board. Use a GPIB cable to connect GPIB interfaces of the instrument and PC. Please ensure that the screws have been screwed down in order to have a full connection.

### GPIB Configuration

Each device on the GPIB (IEEE-488) interface must have a unique whole number address between 1 and 30. Your computer's GPIB interface card address must not conflict with any instrument on the interface bus. This setting is nonvolatile; it will not be changed by \*RST.

When you purchase the interface accessory and successfully insert it into the corresponding position on the rear panel of the instrument, the menu item for changing the GPIB address appears in the System menu. The specific steps are as follows:

1. Ensure that the instrument's power switch is off, that is, the instrument is in Power Off state.
2. Insert the separately purchased GPIB interface card into the card slot on the rear panel of the instrument.
3. Connect the instrument with the computer via the GPIB cable. After the connection is successful, turn on the power switch of the instrument.

4. Press the composite keys [**Shift**] + [**P-set**] (System) on the front panel to enter the system menu.
5. Select **Communication** and press [**Enter**].
6. Select **GPIB** and press [**Enter**].
7. Press the numeric keys to set the GPIB address and press [**Enter**].

## 8.5 RS232 Interface (Optional)

The RS232 interface shares the same communication card (IT-E177) with the analog function.

### RS232 Cable

Use the supplied RS232 cable (one end with a DB9 connector and the other with a flat terminal) to connect the instrument to the PC. The connection method is as follows: the flat terminal connects to the communication board (the board is inserted into the rear panel of the instrument), and the DB9 connector connects to the PC. The connection of the flat terminal is as follows:

- TXD wire (red) connects to Pin1 of the communication board.
- RXD wire (white) connects to Pin2 of the communication board.
- DGND wire (black) connects to Pin3 of the communication board.



#### Note

- If the PC has a DB9 interface, you can directly use the supplied RS232 cable by connecting the DB9 end to the PC.
- If the PC only has a USB interface, you will need an RS232 to USB adapter cable for the connection. This type of adapter cable requires a driver to function correctly as a COM port. Please contact the supplier of the RS232–USB adapter cable for the necessary driver.

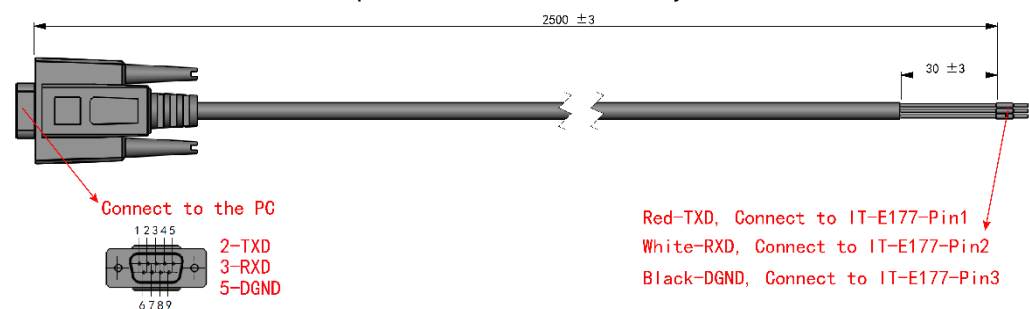

### Definition of RS232 Pins

The definition of RS232 pins are as follows.

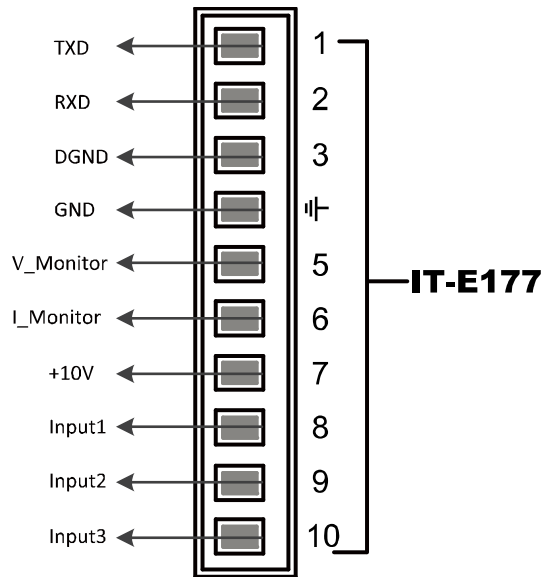

When using the RS232 interface for communication, connect the pin 1, pin 2, and pin 3 of the IT-E177 to the PC. The pin description is as follows:

Pins	Description
1	TXD, transmit data
2	RXD, receive data
3	DGND, ground

## RS232 Configuration

When you purchase the interface accessory and successfully insert it into the corresponding position on the rear panel of the instrument, the RS232 menu item will appear in the System menu. The specific steps are as follows:

1. Ensure that the instrument's power switch is off, that is, the instrument is in Power Off state.
2. Insert the separately purchased RS232 interface card into the card slot on the rear panel of the instrument.
3. Connect the instrument to the computer via an RS232 cable. After the connection is successful, turn on the power switch of the instrument.
4. Press the composite keys **[Shift] + [P-set]** (System) on the front panel to enter the system menu.
5. Select **Communication** and press **[Enter]**.
6. Select **RS232** and press **[Enter]**.
7. Set the relevant communication parameters in turn, and press **[Enter]**.

## RS232 Troubleshooting

If you meet some problems when communicating with PC by RS232 interface, please check the following items:

- Check that whether the baud rate of the computer and instrument are the same;
- Make sure the correct cable and adapter are connected. Note that internal

wiring may not be correct even if the cable has a suitable plug;

- The cable must be connected to the correct serial ports (COM1, COM2, etc) of PC.

## 8.6 EtherCAT Interface (Optional)

The EtherCAT interface is assembled in the IT-E1601-black communication board. You can connect the instrument to the computer via a network cable.

### EtherCAT Configuration

When you purchase the interface accessory and successfully insert it into the corresponding position on the rear panel of the instrument, the menu item for EtherCAT configuration appears in the System menu. The specific steps are as follows.

1. Ensure that the instrument's power switch is off, that is, the instrument is in Power Off state.
2. Insert the separately purchased EtherCAT interface card into the card slot on the rear panel of the instrument.
3. Connect the instrument with the computer via the network cable. After the connection is successful, turn on the power switch of the instrument.
4. Click **System** on the Menu interface to enter the system menu function page.
5. Click the **COMM** tab to enter the communication settings page.
6. Scroll up and down on the **COMM** settings interface to locate the menu item **Card Config**.

At the **Type** function, click the parameter on the right and select **ECAT** from the dropdown options.

7. After making the communication setting, to ensure normal communication, you need to restart the instrument.
8. Repeat steps 4~6 above to view the EtherCAT information.

Display Information	Function
Card Config	-
State: Init/Preop/Safeop/Op	State: Initialization/Pre-operational/Safe-operational/Operational.
Addr: 1001	Slave address (this address is assigned to this slave by the EtherCAT master).
Alias Addr: 1	Slave address alias.
HW Ver: 256	Communication card hardware version number.
Soft Ver: 1	Communication card software version number.

## Appendix

### Specifications of Red and Black Test Lines

ITECH provides you with optional red and black test lines, the user can choose the company's test line for testing. For specifications of ITECH test lines and maximum current values, refer to the table below.

Model	Description
IT-E30110-AB	1kV/10A/1m*2pcs Alligator clips-Banana plugs
IT-E30110-BB	1kV/10A/1m*2pcs Banana plugs-Banana plugs
IT-E30110-BY	1kV/10A/1m*2pcs Banana plugs-Y-type terminals
IT-E30312-YY	500V/30A/1.2m*2pcs Y-type terminals-Y-type terminals
IT-E30320-YY	500V/30A/2m*2pcs Y-type terminals-Y-type terminals
IT-E30615-OO	500V/60A/1.5m*2pcs Ring terminals-Ring terminals
IT-E31005LIC-OO	600V/100A/0.5m*2pcs Ring terminal low inductance
IT-E31010LIC-OO	600V/100A/1m*2pcs Ring terminal low inductance
IT-E31020LIC-OO	600V/100A/2m*2pcs Ring terminal low inductance
IT-E31040LIC-OO	600V/100A/2m*2pcs Ring terminal low inductance
IT-E31220-OO	500V/120A/2m*2pcs Ring terminals-Ring terminals
IT-E31250-OO	500V/120A/5m*2pcs Ring terminals-Ring terminals
IT-E32410-OO	500V/240A/1m*2pcs Ring terminals-Ring terminals
IT-E32420-OO	500V/240A/2m*2pcs Ring terminals-Ring terminals
IT-E32450-OO	500V/240A/5m*2pcs Ring terminals-Ring terminals
IT-E3301020-OO	3kV/100A/2m*2pcs Ring terminals-Ring terminals
IT-E3301050-OO	3kV/100A/5m*2pcs Ring terminals-Ring terminals
IT-E3302420-OO	3kV/240A/2m*2pcs Ring terminals-Ring terminals
IT-E3302450-OO	3kV/240A/5m*2pcs Ring terminals-Ring terminals
IT-E3303620-OO	3kV/360A/2m*2pcs Ring terminals-Ring terminals
IT-E3304020-OO	3kV/400A/2m*2pcs Ring terminals-Ring terminals
IT-E33620-OO	500V/360A/2m*2pcs Ring terminals-Ring terminals
IT-E33650-OO	500V/360A/5m*2pcs Ring terminals-Ring terminals
IT-E34020-OO	500V/400A/2m*2pcs Ring terminals-Ring terminals
IT-E34520-OO	500V/450A/2m*2pcs Ring terminals-Ring terminals
IT-E35030-OO	500V/360A/3m*2pcs Ring terminals-Ring terminals
IT-E36530-OO	500V/650A/3m*2pcs Ring terminals-Ring terminals

For maximum current of AWG copper wire, refer to table below.

AWG	10	12	14	16	18	20	22	24	26	28
The Maximum current value( A)	40	25	20	13	10	7	5	3.5	2.5	1.7

**Note: AWG (American Wire Gage), it means X wire ( marked on the wire). The table above lists current capacity of single wire at working temperature of 30°C. For reference only.**



## Connect with us

Thank you for purchasing ITECH products. Any questions, pls. feel free to let us know.



You can chat with us on ITECH website



For more information, pls. visit [www.itechate.com](http://www.itechate.com)



Click and follow ITECH Electronics

