

Hot jacket remover

JR-7

Guide to operation





IMPORTANT SAFETY PRECAUTIONS

This product has been designed and manufactured to assure personal safety. Improper use can result in bodily injury and serious damage to the jacket remover. Please read and observe all warnings instructions given in this operation manual.



◆ The meaning of these symbols

In the product and this operation manual, symbols are used to highlight warnings and cautions for you to read so that accidents can be prevented. The meanings of these symbols are as follows:

<The meaning of these symbols>

	This symbol indicates a caution, danger, or warning and alerts you important instructions have been included on the product or in the manual.
	This symbol indicates actions that are prohibited.
	This symbol indicates actions that must be taken.

<The meaning of Warning and Caution>

 Warning	This symbol indicates explanations about extremely dangerous matters. If users ignore this symbol and handle the jacket remover the wrong way, serious injury such as fire or electric shock, or death could result.
 Caution	This symbol indicates explanations about dangerous matters. If users ignore this symbol and handle the jacket remover the wrong way, bodily injury and damage to the equipment could result.

Be sure to read all the following warnings and cautions before use.



<Using jacket remover>

	<ol style="list-style-type: none"> 1. This product meets IPX1 (water proof protection Class 1) defined by JIS C0920. However do not intentionally expose the jacket remover to water or touch it with wet hands. Failure to do so may cause fire, electric shock or malfunction. 2. If water gets into the jacket remover, turn off the power and remove the battery or unplug the AC adapter. Next, contact our maintenance service center. 3. If an abnormal condition such as smoke, unusual odor, unusual noise, or heat generation occurs, immediately turn off the power. Next, contact our maintenance service
-------------------------------------------------------------------------------------	--------------------------------------------------------------------------------------------------------------------------------------------------------------------------------------------------------------------------------------------------------------------------------------------------------------------------------------------------------------------------------------------------------------------------------------------------------------------------------------------------------------------------------------------------------------------------------------------------------------------------------------------------------



- center.
- 4. Do not touch the heat plate during use. The heat plate and its peripheral parts are very hot. Doing so may cause burn.
- 5. Do not disassemble or modify this product. Doing so may cause fire, electric shock or malfunction.
- 6. The removal blade has a sharp part in the center, so do not touch it directly.

<Handling of battery>



1. Do not disassemble or modify the battery. Safety and protective devices to prevent danger are built in the battery. If these devices are damaged, excessive current flow may cause heat generation, smoke, bursting and fire.
2. Do not directly connect the positive and negative terminals with a conductive material such as a wire. Do not carry or store the battery together with any personal jewelry, hairpins or other metallic objects. Doing so can cause an electrical short circuit. Also excessive current flow may cause heat generation, smoke, bursting and fire.
3. Do not throw it into a fire or burn the battery. Heat will melt insulates, damage safety devices and cause chemical reaction in battery fluid, resulting in heat generation, smoke, bursting and fire.
4. Do not use or leave the battery under high temperature conditions such as near fire or stove. Doing so may cause heat generation, smoke bursting and fire.
5. Do not let water or sea water wet or soak the battery. Protective devices are built in the battery. If these devices are damaged, excessive current flow may cause, heat generation, smoke, bursting and fire.
6. Do not charge the battery close to heat sources or under the blazing sun. Protective devices to prevent danger are built in the battery. If these devices are damaged, excessive current flow may cause chemical reaction in battery fluid, resulting in heat generation, smoke, bursting and fire.
7. Only use a specified battery charger. Failure to do so can cause the battery to be overcharged or excessive current flow may cause abnormal chemical reaction in battery fluid, heat generation, smoke, bursting and fire.
8. Do not pierce the battery with a needle, strike the battery with a hammer, or step on the battery. Doing so may cause internal short circuit, resulting in heat



- generation, bursting and fire.
9. Do not throw or impact the battery. Protective devices are built in the battery. If these devices are damaged, excessive current flow may cause abnormal chemical reaction in battery fluid, resulting in heat generation, bursting and fire.
 10. Do not solder any lead wires directly to the battery. Heat will melt insulates and damage protective devices, resulting in heat generation, smoke, bursting and fire.
 11. Do not place the battery in microwave ovens, high-pressure containers. Doing so may cause heat generation, smoke, bursting and fire.
 12. Use the battery only for the application for which it was designed. Failure to do so will result in a loss of performance and shortened battery life expectancy. Also excessive current flow may cause damage to the jacket remover, heat generation, bursting and fire.
 13. Do not use or leave the battery under high temperature such as in strong direct sunlight and cars during hot weather. Failure to do so will result in a loss of performance and shortened battery life expectancy.



14. Make sure polarities are correctly connected. Do not attempt to connect the battery module when you cannot do. Reversed connections may cause abnormal chemical reaction in battery fluid, resulting in heat generation, bursting and fire.
15. In the event the battery leaks and the fluid gets into one's eyes, do not rub the eyes. Immediately wash them thoroughly with clean water enough from the tap and consult a doctor urgently. Failure to do so could result in serious damage to the eyes.
16. Optimum temperature range for charging is 0°C to 40°C. Charging the battery at a temperature out of the range may cause leakage, heat generation, or other damages, resulting in a loss of performance and shortened battery life expectancy
17. Do not charge a fully charged battery. Doing so may cause the battery to be heated up, resulting in shortened battery life expectancy.
18. When disposing of the battery, follow the local regulations or contact our maintenance service center.



<Handling of AC adapter and power cord >



1. Only use a supplied DC cord (part number: PC-B[C]) when performing DC operation with a fusion splicer. Failure to do so may cause the jacket remover to operate poorly and malfunction.
2. If you are not going to use the jacket remover for a long period, unplug the AC adapter to reduce the risk of fire.
3. Unplug the AC adapter by grasping the plug, not the cord. Failure to do so may cause damage to the AC cord.
4. Do not plug/unplug the power cord or remove the battery pack with wet hands.

<Storage >



1. Avoid places with too much moisture, dust and dirt. Failure to do so may cause fire, electric shock or malfunction.

<Using jacket remover / Maintenance >



1. For your safety do not remove glass fiber fragments with bare hands after removal. Use a supplied cleaning brush and clean the blade peripheral parts with it.
2. Prepared fiber and glass fiber fragments are extremely sharp. Handle with care.
3. Blades are consumables. Only use Sumitomo genuine blades for replacement. Always replace both blades at a time. Install the blades in place. Failure to do so may cause the jacket remover to be damaged or deteriorated in performance.
4. Please note that dropping from a high place may cause damage.
5. When changing the blades, the removal blade has a sharp part in the center. Do not touch it directly.

<Handling of battery>



1. Do not remove the battery with wet hands. Failure to do so may cause fire, electric shock or malfunction.
2. Charge the battery at an ambient temperature in the range from 0°C to 40°C. Avoid charging the battery at extremely low temperature (below 0 °C). Failure to do so may result in shortened battery life expectancy and battery leakage.
3. If you are not going to use the battery for a long period, remove it from the jacket remover. Failure to do so will shorten battery life expectancy as very little current flows while the jacket remover with a battery is powered off.

Table of contents

IMPORTANT SAFETY PRECAUTIONS

1. General	1
2. Product overview	1
Specification	1
Standard package / Options	1
3. Structure	2
4. Preparing power supply	3
Battery operation	3
Battery level check	3
Charging the battery	3
Battery replacement	3
AC operation	4
DC12V supplied from Sumitomo fusion splicer	4
5. Operating procedures	4
6. Temperature settings	6
7. Switching to HEATER MODE	6
8. Auto power off function	7
9. LED Light	7
10. Vibration	7
11. Setting memory	7
12. Maintenance	7
Cleaning	7
Blade replacement	8
Troubleshooting	9
13. Battery storage	10

1. General

Thank you very much for purchasing the JR-7 hot jacket remover.

This product is designed to remove the coating of "200µm 12-fiber ribbon and pliable ribbon", and "250µm ribbon fibers and pliable ribbon". It features the industry's first hot jacket remover that meets IPX2 (water proof protection Class 2) defined by JIS C0920 and achieves splash-proof and excellent removing performance with compact and lightweight body. This product is equipped with both LED lighting and vibration functions for enhanced user experience. Before using the JR-7, read this manual carefully in its entirety to fully understand product capabilities. Save this manual in a location in which you can easily get to see.

The JR-7 is designed for splash-proof performance and meets IPX2 (water proof protection Class 2; vertically falling drops shall have no harmful effect) defined by JIS C0920. However please note that it does not provide any guarantees that accident and damage will not arise.

Splash-proof design



Power source	2) DC 12V supplied from Sumitomo fusion splicer with optional PC-B[C] DC cord Input voltage DC 9~15V Output voltage DC 9~15V 3) AC operation: Input voltage AC 90~264V, 50/60Hz, with ADC-1220S AC adapter
Battery operating time (Estimated removal cycles) *1	100°C setting : Approx. 10h (Approx. 600 cycles)
Dimensions	46(W) x 146(D) x 37.5(H) mm
Weight	Approx. 253g (including battery)
Environmental conditions	Operating temp: -10°C~+50°C *2 Storage temp: -40°C~+80°C (Not applicable to the battery) Humidity: ≤95% RH (non-condensing) Water resistance: Equivalent to IPX2 *3

- *1 With a brand new fully charged battery, removal shall be conducted at 1 minute interval in power save mode at room temperature (25°C). The operating time and removal cycle vary according to operational environments.
- *2 The battery should be charged within the temperature range.
- *3 IPX2 is defined as "vertically falling drops shall have no harmful effect".
- *The specification and design are subject to change without prior notice.

2. Product overview

Specification

Optical fiber requirement	
Material	Silica glass
Coating material	UV cure resin
Fiber count	Single fiber: φ200~φ400µm
Coating thickness *1	2~12c fiber ribbons: Coating thickness 200~400µm
Cladding diameter	125µm
Coating removal length	Max. 35mm

*1 Sumitomo FHS series (for single fiber) or FHM series (for ribbon fibers) fiber holders are needed to remove fiber coating with the JR-7.
FHM-12N or PCH-12 (for fiber pitch conversion) fiber holders are needed to remove coating of 200µm 12-fiber ribbons.

Specification	
Temperature settings	4 temperatures: Approx. 80°C~140°C
Power saving function	NORMAL MODE POWER SAVE MODE
Battery level check	Indicated in one of four levels (With indicator)
Fiber holding method	FHS, FHM or PCH series fiber holders shall be used.
Power source	1) Battery operation: Nominal capacity 1940mAh Operation with BU-6A battery

Standard package / Options

<Standard package contents>

Part name	Part no.	Q'ty
Hot jacket remover *1	JR-7	1pc
Battery *2	BU-6A	1pc
AC adapter	ADC-1220S	1pc
AC cord for AC adapter	PC-AC [*3]	1pc
Precaution card (English) *1	ETK2326053	1pc
Carrying case *1	SSB-02	1pc
Strap *1	-	1pc
DC cord *4	PC-B[C]	1pc
Cleaning brush *1	-	1pc
Hex driver (US) or Allen key (UK) 1.3mm *1	-	1pc

- *1 Items are not sold separately.
- *2 Contained in the main body upon shipment.
- *3 [2-2P]: for U.S.A., [3-2P]: for EU etc., [6-2P]: for AUS
- *4 DC cord for connection between Sumitomo splicer and JR-7.

<Options>

Part name	Part no.	Q'ty	Remark
Replacement blades *1	JR-7BL	1pair	Upper and lower blades
Battery	BU-6A	1pc	
AC adapter	ADC-1220S	1pc	Comes with power cord
DC cord	PC-B[C]	1pc	For supply of power from splicer

*1 Please be sure to use a dedicated replacement blade "JR-7". Using the old type blade "JR-6+BL" does not meet the spec for product performance.

<Options>

Part name	Part no.	Q'ty	Remark	
Fiber holders	For 200µm fiber	FHM-12N	1pair	For 12c fiber ribbon
		PCH-12A	1pair	For fiber pitch conversion
		PCH-12V		
	For 250µm fiber	FHS-025	1pair	For single fiber
		FHM-2	1pair	For 2c fiber ribbon
		FHM-3	1pair	For 3c fiber ribbon
		FHM-4	1pair	For 4c fiber ribbon
		FHM-5	1pair	For 5c fiber ribbon
		FHM-6	1pair	For 6c fiber ribbon
		FHM-7	1pair	For 7c fiber ribbon
		FHM-8	1pair	For 8c fiber ribbon
		FHM-9	1pair	For 9c fiber ribbon
FHM-10		1pair	For 10c fiber ribbon	
FHM-11	1pair	For 11c fiber ribbon		
FHM-12V	1pair	For 12c fiber ribbon		

3. Structure

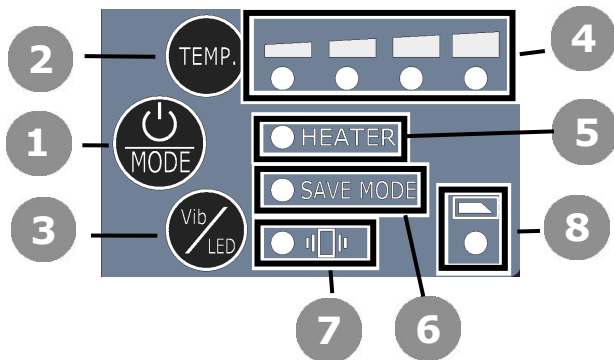
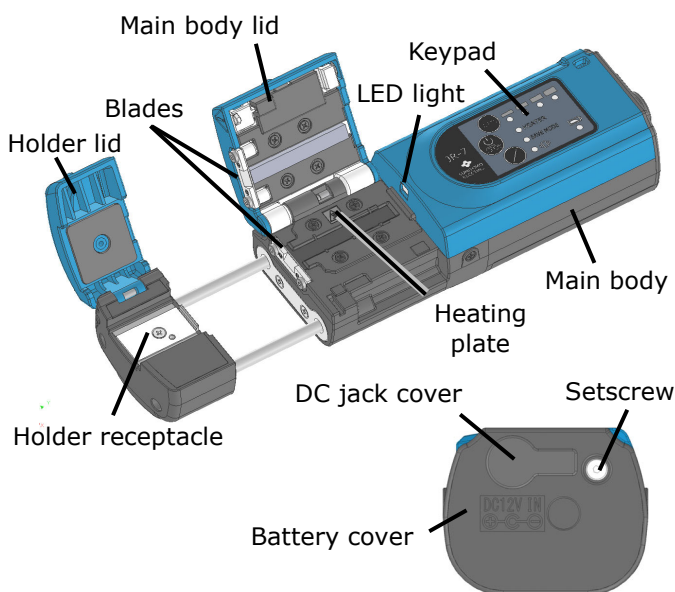

1 POWER / HEATER MODE key

ON/OFF key
Choose NORMAL/POWER SAVE MODE while the power is on.



2 Heat plate temperature switching key

Change the heater temperature.



3 Vibration & LED light switching key

Turns ON/OFF the vibration/LED light while the power is on.



4 Heater temperature LED

Illuminates to indicate the heater temperature.



5 HEATER LED

Illuminates when the heating plate is heated up.



6 SAVE MODE LED

Illuminates when the POWER SAVE MODE is set.



7 Vibration LED

Illuminates when the vibration is turned on.



8 Battery indicator LED

Illuminate to indicate the battery power level.



4. Preparing power supply

There are 3 power supply methods for JR-7 operation.

1. Battery operation
2. AC operation
3. DC12V supplied from Sumitomo fusion splicer

Battery operation

Before using for the first time, charge the battery. (The battery is not fully charged before shipping.)

The BU-6A battery is a rechargeable Lithium-Ion battery. You can recharge the battery before you have fully discharged it.

The BU-6A battery is pre-installed in the JR-7 upon delivery.

Battery level check

Battery indicator LED (8) light up to give an instant indication of a current battery remaining capacity in one of four levels.

LED	Battery level (%)
● (Green)	More than 30%
● (Orange)	20% ~ 30%
● (Red)	10% ~ 20%
● (Red blinking)	Below 10%

If a battery level is below 10% during operation, the leftmost LED flashes in red to warn the battery will be dead soon.

*Battery level LEDs only show an approximate battery level.

Charging the BU-6A battery

The BU-6A can be charged while installed in the JR-7.

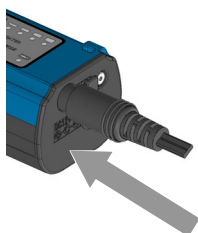

1. Make sure the BU-6A is installed in the JR-7.
2. Connect the ADC-1220S AC adapter to the DC jack of the JR-7 and plug it in.

3. When the battery charge is started, the leftmost LED of the BATT. indicator LEDs flashes in green.
4. The charging time is different depending on the remaining capacity. Typically charge is complete in approximately 2 hours. The leftmost LED of the BATT. indicator LEDs lights up green.

LED status	Meaning
Green Lit	Fully charged
Green Flashing	Being charged.
Green/Red Alternately lit	BU-6A or JR-7 is faulty.

*If an abnormal condition occurs, immediately contact our service department.



Warning

Charge the battery within a temperature range of 0°C to 40°C. Failure to do so will shorten battery life and may cause battery leakage, heat generation, bursting and fire.



Caution

Only use the JR-7 and the ADC-1220S AC adapter (or Sumitomo fusion splicer) to charge the battery. Failure to do may cause electric shock or fire.

Battery replacement

1. Unscrew the setscrew with a supplied 1.5mm Hex driver (US) or Allen key (UK) to remove the battery cover.

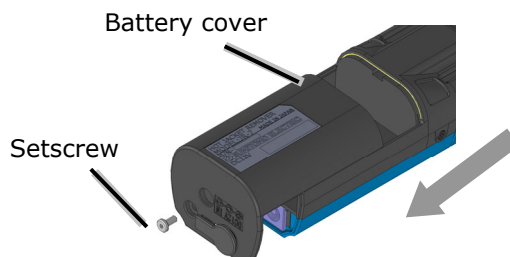

2. Install a new battery into the JR-7 as shown below.

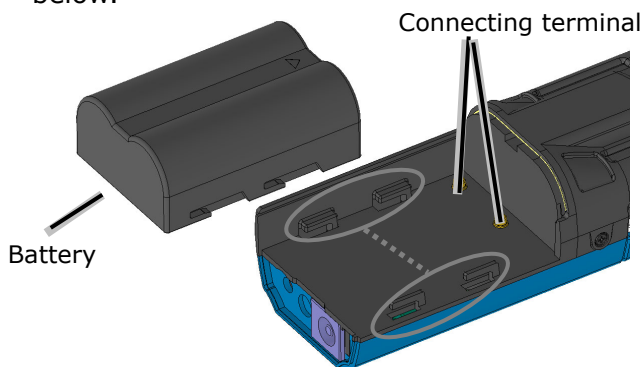

Engage the circled parts into each other and then slide the battery.

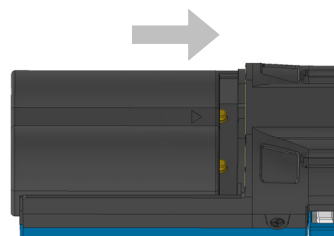

3. Re-fit the battery cover. Tighten the setscrew with a 1.5mm Hex driver (US) or Allen key (UK). (*Optimum torque: 10.0cNm*)

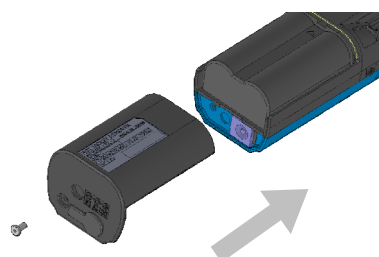

Caution

Install the battery with a correct polarity.

Caution

Be sure to close the cover completely. A gap between parts will not bring out satisfactory splash-proof performance.

AC operation

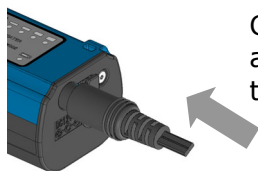

Connect the ADC-1220S AC adapter to the DC jack of the JR-7 and plug it in.



When the ADC-1220S AC adapter is connected to the JR-7 with the battery installed and the JR-7 is powered on, AC operation is started. (Battery operation is not available.)

DC12V supplied from Sumitomo fusion splicer

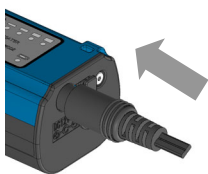

1. Connect a supplied DC cord (part number: PC-B[C]) to the DC jack of the JR-7.
2. Connect the DC cord to the DC output terminal of a fusion splicer.

*This function is only available on the fusion splicer which is equipped with a DC output terminal. For more information, please see the operation manual supplied with the splicer you use.

5. Operating procedures



1. Press the POWER key (1) for more than 1 second until the temperature LEDs illuminate. The JR-7 vibrates regardless of the setting when turned ON/OFF.



2. When the JR-7 reaches the temperature, the HEATER LED (5) turns green from red.



*The optimum heater temperature varies depending on the optical fiber used. Please refer to Section 6 "Temperature settings" for how to change the temperature.
*For 200 μm fiber and freeform ribbon fiber, the fourth from the left (highest) is recommended.

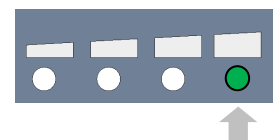

3. Place an optical fiber in a fiber holder with the Approx. 30mm.

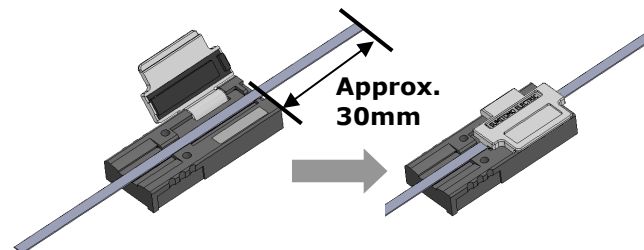

4. Place the fiber holder in the holder receptacle.

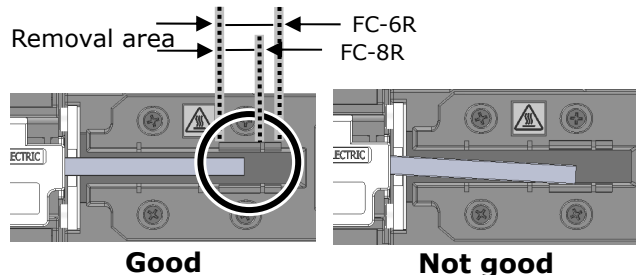
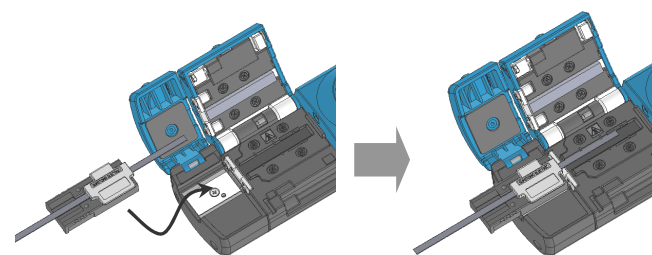

With use of Sumitomo fiber cleavers, ensure that the coating end is positioned in a specified removal area.

5. Close the main body lid and holder lid. The HEATER LED (5) flashes in green for Approx. 3 seconds, and then keeps illuminated. (At the same time the JR-7 vibrates if the vibration setting is ON.)

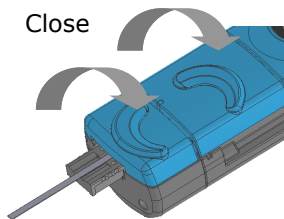

The HEATER LED flashes in green for Approx. 3 seconds.



The HEATER LED lights up green.

6. Ensure that the HEATER LED (5) is lit in green and then hold the JR-7, particularly the push area of the main body lid firmly. Slide the holder receptacle and holder lid slowly in the direction indicated by the arrow.

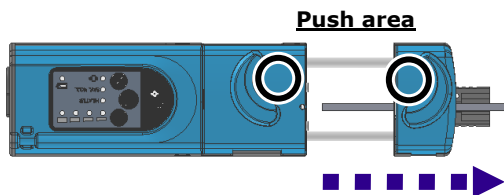

Tips

Hold the "push area" firmly.

Instruction on how to hold

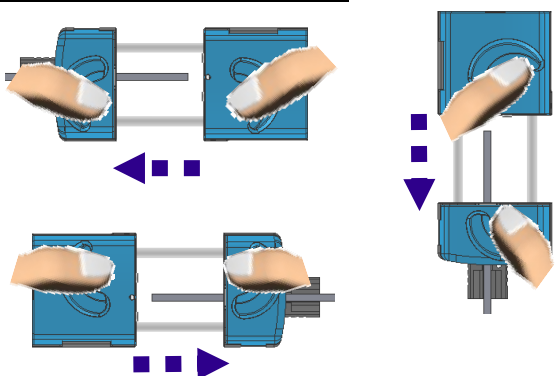

*Place your finger on the convex part.

Tips

Tip 1- Hold main body lid while LED flashes

For the purpose of conducting heat to the fiber completely, after closing the main body lid and holder lid, hold straight down the PUSH area of the main body lid firmly as soon as the HEATER LED flashes.

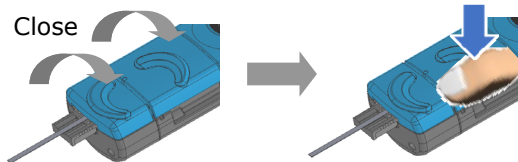

- While keep holding the push area, apply force straight down.
- Do not apply force to the holder lid and key panel.
- Make sure the PUSH portion is held firmly.
- Take care not to move around the main body lid and holder lid.



Tip 2- How to slide holder lid and receptacle

After making sure the HEATER LED lights up (and stays solid), keep holding the main body lid and holder lid firmly and not move the main body. Then slide the holder lid and holder receptacle slowly, keeping them levelled.

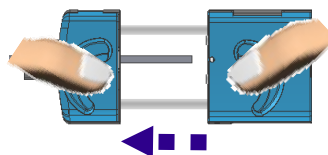

- Slide the holder lid and holder receptacle slowly, keeping them levelled. Do not apply excessive force up/down/left/right.
- When sliding make sure you hold the main body lid and holder lid firmly.
- When sliding take care not to move the main body.

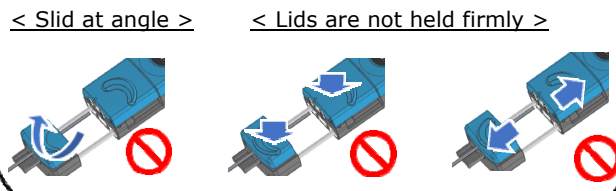

7. Coating removal is complete. Take out the fiber holder from the JR-7. Take out the removed coating jacket with a supplied cleaning brush or tweezers.

Removed coating jacket

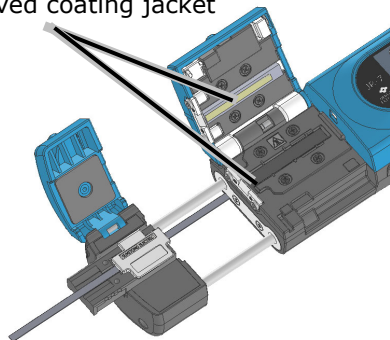

 Caution	Be sure to take out the removed coating jacket and dispose of it properly.
-------------	----------------------------------------------------------------------------



8. Press the POWER key (1) for more than 1 second until the indicator LEDs go off.

9. Clean the bare fiber from the end of the fiber coating with a lint-free gauze pad moistened with pure (more than 99%) alcohol. Pull the bare fiber in the direction indicated by the arrow through the gauze pad (if cleaning ribbon fiber).

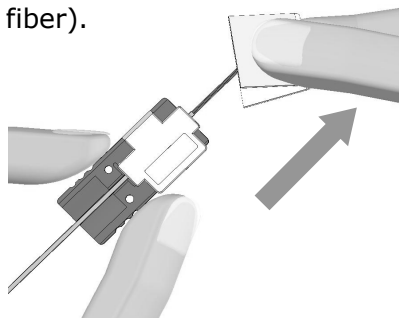

* Do not reuse the gauze pad that was used.

10. Lightly brush the ends with your finger to fan out all fibers in a straight line (if cleaning ribbon fiber).

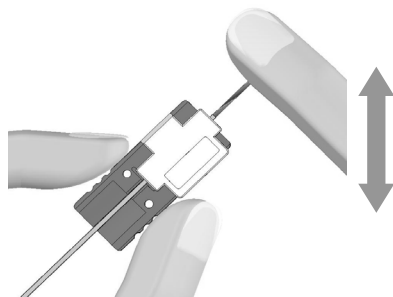

 Caution	Glass fiber is extremely sharp. Handle with care.
-------------	---------------------------------------------------

6. Temperature settings

The temperature can be changed by using the TEMP. key (2). It is pre-set to the 2nd from the left upon power up.

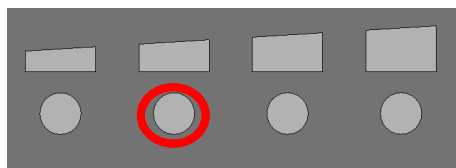

Basically, the 2nd from the left setting is recommended.

If the coating jacket remains on the fiber, set to the higher temperature.

If the removed coating jacket breaks into fragments, set to the lower temperature.

7. Switching to HEATER MODE

While the JR-7 is powered on, you can switch between NORMAL MODE and POWER SAVE MODE by pressing the POWER key (1) quickly (less than 1 second).

Generally NORMAL MODE is recommended.

*If the POWER key (1) is pressed for more than 1 second, the JR-7 is powered off.

1. NORMAL MODE

Enables to use the JR-7 continuously with no waiting time.

2. POWER SAVE MODE

Enables to minimize power consumption and extend battery operating duration. The JR-7 turns off the heat every time you open the lid. If the main body lid is not opened or closed for Approx. 20 seconds after the HEATER LED (5) turns green from red, the JR-7 decreases the heat temperature and keeps low. (The HEATER LED (5) is lit in red.) If the main body lid is opened or closed, the JR-7 starts to increase the temperature.

8. Auto power off function

If the main body lid is not opened, closed, or operated for approximately 5 minutes, the JR-7 will automatically turn off the heater.

If the main body lid is not opened, closed, or operated for approximately 15 minutes, the JR-7 will automatically turn off.

9. LED Light

The JR-7 has an LED lighting function.

Press the Vib/LED button quickly to turn ON/OFF the light.



10. Vibration

The JR-7 has a vibration function.

Press and hold the Vib/LED button to turn ON/OFF the vibration.

When it is turned on, the vibration indicator lights up in green.

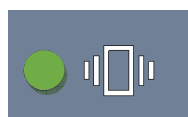

11. Setting memory

The JR-7 can save the last used settings of the following functions when the power is turned off.

Item	Settings
1	Heater temperature
2	Normal mode/Save mode
3	Vibration ON/OFF
4	LED Light ON/OFF

12. Maintenance

Cleaning

To keep the JR-7 in good condition, be sure to clean it before and after use.

Before cleaning the JR-7, make sure that it is in the following conditions.

1. The JR-7 is powered off.
2. The heating plate is cooled down. (Wait for more than 5 minutes after the JR-7 is powered off.)

Clean the blades, contacting surface, recessed section, heating plate and rubber pad with a cotton swab moistened with pure (more than 99%) alcohol.

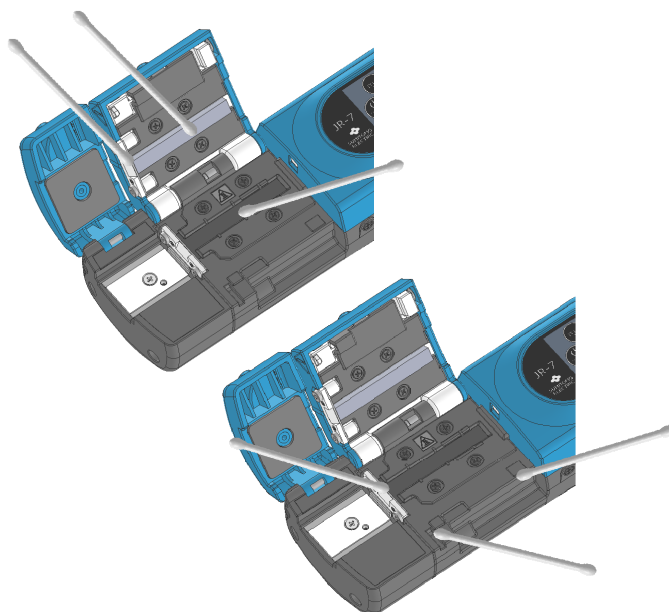

Tips

Blade edge and back

Contacting surface

Blade edge and back

Contacting surface

Contacting surface

Recessed section

Remove fiber coating debris completely from the "Contacting surface", "Recessed section" and "Blade edge and back".

Caution

1. Dust such as coating residue on the blades, contacting surface, heating plate and rubber pad may cause removal performance to be deteriorated.
2. Do not use chemicals other than pure alcohol. Alcohol with low purity will rust the blades and deteriorate the rubber pad easily.

Blade replacement

It is recommended that the blades be replaced by our service department. Blades are very sharp. Handle with care.

Before replacing the blades, make sure that the JR-7 is in the following conditions.

1. The JR-7 is powered off.
2. The battery is removed from the JR-7.
3. The heating plate is cooled down. (Wait for more than 5 minutes after the JR-7 is powered off.)

	<p>Always replace the upper and lower blades at a time. Upper and lower blades are the same. Please be sure to use a dedicated replacement blade "JR-7BL". Using the old type blade "JR-6BL/JR-6+BL" does not meet the spec for product performance.</p>
-----------------------------------------------------------------------------------	----------------------------------------------------------------------------------------------------------------------------------------------------------------------------------------------------------------------------------------------------------

1. Unscrew the setscrews with a supplied 1.3mm Hex driver (US) or Allen key (UK). Remove the upper and lower blades.

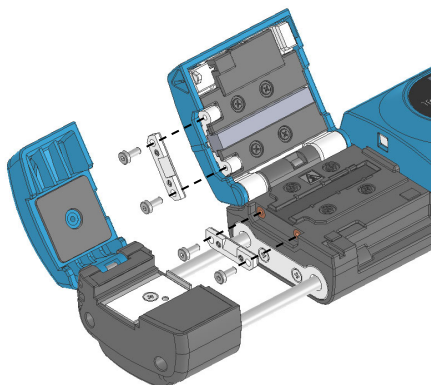

2. Fit a new lower blade to the JR-7 and then tighten the setscrews temporarily.

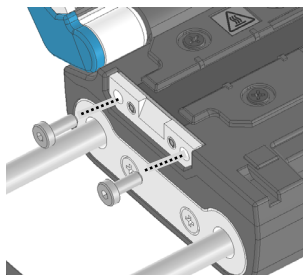

3. Fit a new upper blade to the JR-7 and then tighten the setscrews temporarily.

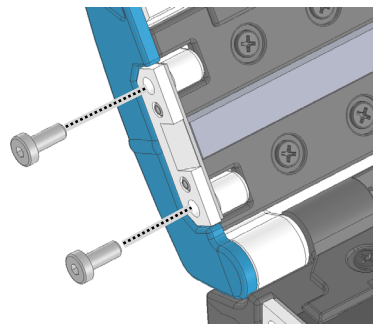



4. Loosen the setscrews of the upper and lower blades so that the blades are a bit movable back and forth.

	<p>Ensure that the upper and lower blades are a bit movable.</p>
------------------------------------------------------------------------------------	------------------------------------------------------------------

5. Adjust the positions of the blades.

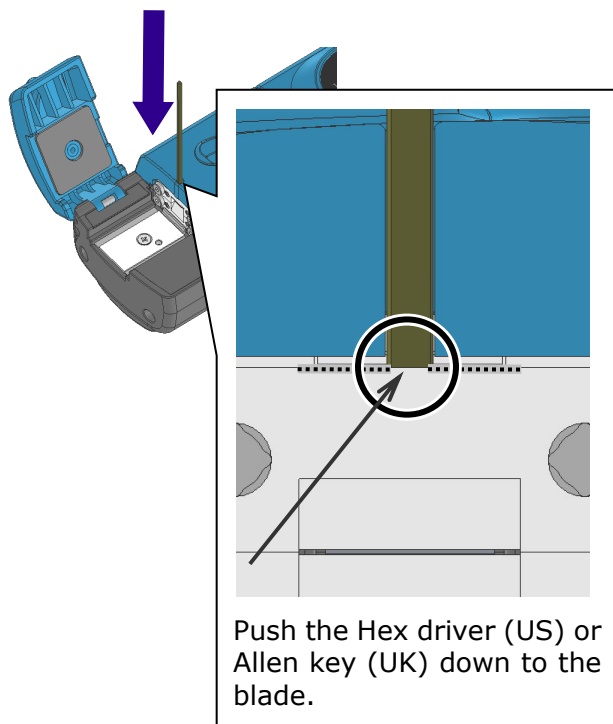
Close the main body lid. Put a 1.3mm Hex driver (US) or Allen key (UK) in the hole of the center. While keep pushing the Hex driver (US) or Allen key (UK) down to the upper blade in the arrow direction, tighten the setscrews so that the upper blade is aligned with the lower blade. (Optimum torque: 17.6cNm)



	<p>Tighten the left and right setscrews alternately with even force.</p>
-------------------------------------------------------------------------------------	--------------------------------------------------------------------------

Troubleshooting



Good

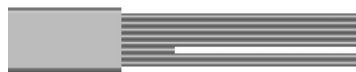

No good

Fiber is broken.



Fiber coating is not removed nicely.



Fiber coating cannot be removed.

If a problem with removal occurs, the followings are possible causes.

- (A) Cleaning is not conducted fully.
Dust such as coating residue on the blades, heat plate and rubber pad may cause the removing performance to be deteriorated.
- (B) The blades do not touch the fiber coating.
 - 1. The blades are not fitted to the JR-7 properly. Check to see if the blades are fitted to the JR-7 properly.

Refer to "12. Maintenance-Cleaning".

Refer to "12. Maintenance-Blade replacement".

- 2. The blades are worn out.
If the problem still persists despite correct blade fitting, the blades may be worn out.
- 3. The push portion of the main body lid is not pressed fully.
Hold the push portion firmly when removing fiber coating.

Refer to 12. Maintenance-Blade replacement".
Contact our service department.

Refer to "5. Operating procedures".

- (C) Fiber coating is hard to remove. Fiber coating is crumbled.
Depending on the fiber coating materials or ambient temperature, the remover temperature needs to be changed. Generally, the temperature should be increased at low ambient temperature.

Refer to "6. Temperature settings".

Tips

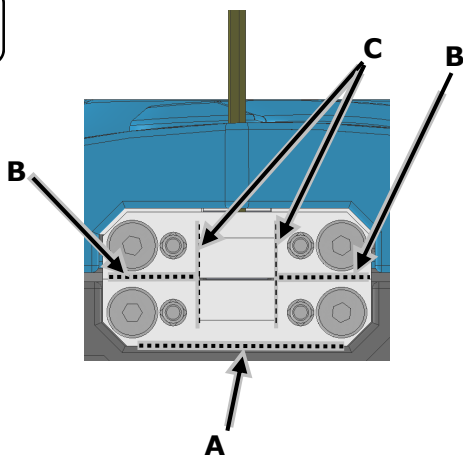

A: There should not be a gap between the lower blade and JR-7 main body.

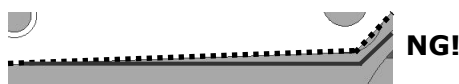

B: There should not be a gap between the upper and lower blades.

C: The upper and lower blades should be aligned with each other.



Perform Step 1 through Step 10 of "5. Operating procedures" to ensure that blade replacement has been done properly.

6. Attempt to remove the coating of ribbon fiber a few times. Lightly brush the ends with your finger to ensure that the fiber is not broken.

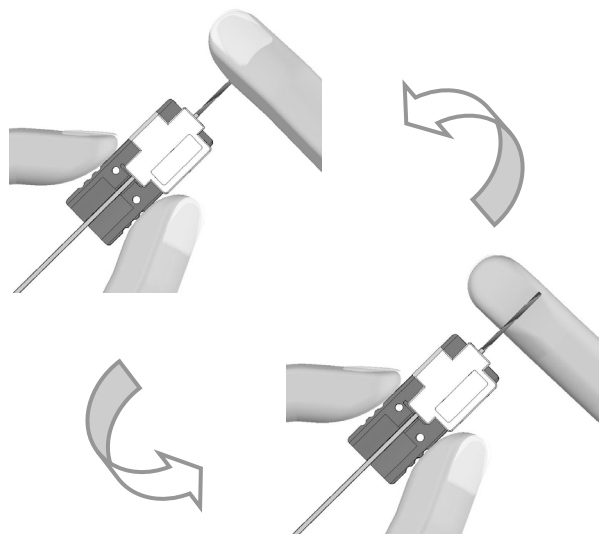

Caution

Take care not to prick your finger with fiber.

13. Battery storage

If you are going to store the battery for more than 1 month, observe the followings.

1. Remove the battery from the JR-7.
(Refer to "4. Preparing power supply-Battery replacement".)
2. Store the battery in a cool temperature e.g. Approx. 20 °C.
3. Recharge the battery for Approx. 20 minutes once a year.
(Refer to "4. Preparing power supply-Charging the battery".)

Original: Oct. 11, 2023

Issue A: Feb. 5, 2024

*Tokyo (JAPAN)***Sumitomo Electric Industries, Ltd.**
(Global Business Dept.)Akasaka Center Building, 1-3-13,
Motoakasaka, Minato-ku, Tokyo
107-8468, JAPAN

Tel: +81 (0)3 6406 2666

<http://global-sei.com/sumitomo-electric-splicers>*North Carolina (U.S.A)***Sumitomo Electric Lightwave Corp.**201 South Rogers Lane, Suite 100
Raleigh, NC27610 U.S.A

Toll Free No. 800 358 7378

Tel: +1 919 541 8100

<http://www.sumitomoelectric.com>*London (U.K)***Sumitomo Electric Europe Ltd.**220 Centennial Park, Centennial Avenue,
Elstree, Herts, WD6 3SL, U.K.

Tel: +44 (0)20 8953 8118

<http://www.sumielelectric.com>*Hong Kong (China)***Sumitomo Electric Asia, Ltd.**

Tel: +852 2576 0080

<http://www.seac-cn.com/>*Bangkok (Thailand)***Sumitomo Electric (Thailand) Limited**

Tel: +66 (0)2 260 7231 to 5

<http://www.set-th.com/>*Singapore***Sumitomo Electric Asia Pacific Pte. Ltd.**

Tel: +65 6261 3388

<http://www.seps.com.sg/>*Dubai (U.A.E.)***Middle East office**

Tel: +971 4 701 7338

*Gurgaon (India)***SEI Trading India Pvt. Ltd. (SETI)**

Tel: +91 124 4577 470

*Manila (Philippines)***SEI (PHILIPPINES) INCORPORATED**

Tel: +63 2 811 2755/2756