

# User's Manual

Regulated DC Power Supply  
PXT Series

**PXT20K-500**

**PXT20K-1000**

**PXT20K-1500**

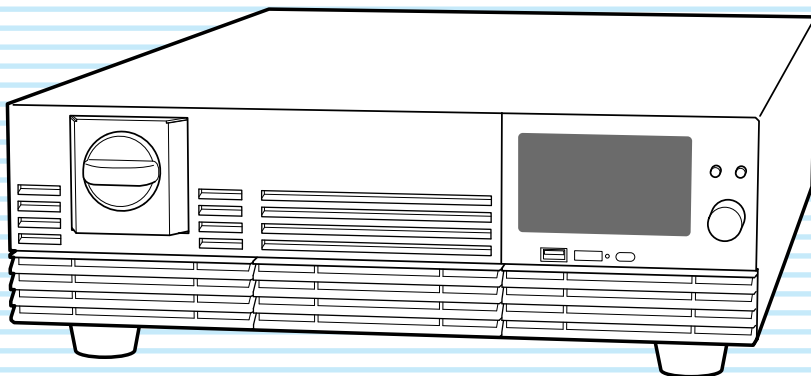

General Description **7**

Component Names **13**

Preparation **16**

Basic Operation **34**

Protection Functions **58**

Advanced Functions **70**

Memory Function **95**

Sequence Function **105**

External Control **127**

System Settings **148**

Maintenance **171**

Specifications **177**

Appendix **190**



# Contents

## General Description

About Manuals .....	7
Disposal.....	7
Open Source Software .....	7
Accessories .....	8
Product Overview .....	10
Notations Used in This Manual.....	10
Safety Precautions .....	10
Notes on Usage.....	12

## Component Names

Front Panel.....	13
Touch Panel Display (Homepage).....	14
Rear Panel .....	15

## Preparation

Connecting the Power Cord .....	16
Preparing for connection .....	17
Connecting the power cord.....	18
Attaching the Terminal Cover.....	21
Attaching the SENSING terminal cover.....	21
Attaching the DC OUTPUT terminal cover.....	21
Checking Whether the Power is On or Off .....	24
Turning the power on.....	24
Turning the power off.....	25
Setting the Date/Time.....	26
Connecting to the DUT .....	27
Output destabilizing DUT.....	27
Grounding the DC OUTPUT terminal.....	29
Connecting the DUT .....	30

## Basic Operation

Operating Area .....	34
Touch Operation.....	35

Touch operation .....	35
Mouse operation.....	35
Displaying the menu.....	36
Changing values.....	37
Homepage.....	38
Number and Character Input.....	38
Touch panel operation.....	39
Operations of the rotary knob and the ◀ / ▶ keys	39
Output ON/OFF .....	40
Displaying the Measured Value and Setting the Output Value .....	41
Error display .....	42
Setting the Priority Operation Mode .....	43
Setting Bleeder.....	44
Operation duration after output OFF operation ...	45
Setting the Output Mode .....	46
Measurement Recording.....	47
Recording measured values.....	47
Changing the settings of measurement.....	48
Changing the integration settings.....	53
Displaying the measured value recorded.....	55
Exporting measured values to a USB memory device.....	56
Displaying the most recent integrated values.....	57

## Protection Functions

Alarm Types .....	58
LOW alarm .....	58
HIGH alarm .....	59
Setting the Protection Functions .....	61
Setting overvoltage protection (OVP).....	61
Setting undervoltage protection (UVP).....	62
Setting overcurrent protection (OCP).....	63
Setting overpower protection (OPP).....	64
Setting grid overvoltage protection (LOVP).....	65
Setting communication error protection (WDOG).	66
Remedying Alarm Generation.....	67
When an alarm occurs .....	67
Checking alarm screen.....	68

Clearing an alarm..... 69

Saving to the setup memory ..... 100  
 Recalling the setup memory ..... 103  
 When the setup memory is not displayed (USB  
 memory device only)..... 104

## Advanced Functions

Remote Sensing ..... 70  
 Connecting the sensing cables ..... 70  
 Enabling or disabling remote sensing ..... 72  
 Response ..... 73  
 Slew Rate ..... 74  
 Setting slew rate..... 74  
 Setting Output Delay ..... 75  
 Settings at Startup ..... 76  
 Output State at Startup..... 77  
 I-V Characteristic Function ..... 78  
 Setting I-V characteristics ..... 79  
 Enabling the I-V characteristic function..... 82  
 Internal Resistance Function ..... 83  
 Setting resistance..... 83  
 Enabling the internal resistance function ..... 84  
 Synchronized Operation ..... 85  
 Connection for synchronized operation..... 85  
 Synchronization of output ON/OFF ..... 86  
 Synchronization of the measurement start..... 87  
 Synchronization of the program start ..... 88  
 Synchronization of the step start..... 89  
 Returning from synchronized operation to  
 standalone operation..... 89  
 Parallel Operation..... 90  
 Making connections for parallel operation..... 91  
 Performing parallel operation ..... 93  
 Behavior during parallel operation ..... 93  
 Changing from parallel operation back to stand-  
 alone operation ..... 94

## Memory Function

Memory Types..... 95  
 Preset Memory ..... 96  
 Saving to preset memory ..... 96  
 Recalling preset memory entries..... 97  
 Setting the confirmation operation when recall-  
 ing memories..... 98  
 Setup Memory ..... 99

## Sequence Function

Overview of the Sequence Function ..... 105  
 Configuration of sequence ..... 105  
 Main functions ..... 106  
 Program Configuration ..... 107  
 Displaying the program list screen..... 107  
 Creating a program ..... 107  
 Changing program settings..... 108  
 Changing a program name ..... 110  
 Saving the program..... 111  
 Deleting a program ..... 112  
 Setting Steps ..... 113  
 Displaying the step list screen ..... 113  
 Creating steps ..... 114  
 Changing the step settings ..... 115  
 Deleting a step ..... 120  
 Executing, Pausing, and Stopping  
 Sequences ..... 121  
 Registering the program in the chain ..... 121  
 Unlocking a chain..... 122  
 Executing sequences..... 123  
 Stops the sequence ..... 124  
 Pausing a sequence ..... 124  
 Exporting and Importing Programs..... 125  
 Exporting programs to a USB memory device.... 125  
 Importing programs from a USB memory device 126  
 In the case that the program cannot be used .... 126

## External Control

Overview of the External Control..... 127  
 EXT CONT Connector Pin Arrangement..... 128  
 Connecting to the EXT CONT Connector ..... 129  
 Connecting to the analog input terminal ..... 129  
 Connecting to the analog output terminal ..... 130  
 Connecting to the digital input terminal..... 131  
 Connecting to the digital output terminal..... 132  
 Connecting to the EXT CONT connector..... 133

Setting Analog Input/Output .....	134
Enabling analog input/output .....	134
Setting the input range of the voltage control signal .....	135
Setting the input range of the current/power control signal .....	136
Setting the output range of the voltage control signal .....	137
Setting the output range of the current control signal .....	138
Setting Digital Input/Output .....	139
Enabling/disabling the digital input/output .....	139
Setting the functions of the general-purpose digital inputs .....	140
Setting the functions of the general-purpose digital output .....	142
Changing the filter for digital input .....	144
Changing the polarities for digital input .....	145
Changing the polarities for digital output .....	146

## System Settings

Communication Setting .....	149
Displaying LAN settings .....	149
Changing LAN settings .....	150
Checking / changing the RS232C communication settings .....	152
Displaying USB settings .....	153
Setting Multichannel .....	154
Multichannel .....	154
Set Multichannel .....	154
Check the settings of Multichannel .....	157
Displaying the Device Information .....	158
Key Lock .....	159
Setting key lock level .....	159
Enabling or disabling the key lock .....	160
Buzzer Sound .....	161
Enables or disables buzzer .....	161
Returning the buzzer to the factory default setting .....	161
Screen Brightness .....	162
Setting screen brightness .....	162
Returning the display brightness to the factory default setting .....	162
Setting the Date/Time .....	163
Retrieving the time from an NTP server .....	163
Setting the time manually .....	165
Updating .....	166
Factory Default Settings and Reset Settings ..	167
Restoring the factory default settings .....	167
Returning the LAN settings to the factory default values .....	168
Resetting the LAN settings .....	168
Restoring to reset settings .....	169
Displaying SCPI Errors .....	170

## Maintenance

Cleaning the Dust Filter .....	171
Removing the dust filter .....	172
Cleaning the dust filter .....	172
Attaching the dust filter .....	173
Inspection .....	174
Periodic inspections .....	174
Backup battery replacement .....	174
Calibration .....	174
Disposal .....	175
Removing the battery at the time of disposal .....	175

## Specifications

Output Specifications .....	177
Output rating .....	177
Output voltage .....	178
Output current .....	179
Output power .....	179
Input Specifications .....	180
200 V three-phase three-wire input .....	180
400 V three-phase three-wire input .....	180
Display Specifications .....	181
Protection Specifications .....	182
LOW alarm .....	182
HIGH alarm .....	183
External Control Specifications .....	184
External analog I/O .....	184
External digital input .....	184
External digital output .....	185
Communication Specifications .....	186

Others ..... 187  
General Specifications..... 188  
Outline Drawing ..... 189  
    PXT20K-500, PXT20K-1000, PXT20K-1500 ..... 189

## Appendix

Settings at Factory Default and at Reset..... 190  
Selecting the Load Cables..... 192  
Guide for Required Time for Residual Voltage Discharge ..... 193  
Discharge Capacity after Output OFF Operation..... 195  
Setting Range and Resolution During Parallel Operation ..... 196  
    Setting range during parallel operation ..... 196  
    Setting resolution during parallel operation ..... 197  
Options ..... 198  
    Load cable..... 198  
    Three-phase input power cord ..... 198  
    Parallel operation signal cable kit..... 198  
    Rack mount bracket ..... 199  
    GPIB converter (PIA5100) ..... 200  
Troubleshooting..... 201  
Index..... 204



# General Description

## About Manuals

This manual provides an overview of the product and notes on usage. It also explains how to configure it, operate it, perform maintenance on it, and so on. Read this manual thoroughly before use, and use the product properly.

### Intended readers

These manuals are intended for users of this product and their instructors. The manuals assume that the reader has knowledge about power supplies.

### Manual construction

#### User's Manual (this manual)

This document is intended for first-time users of this product. It provides an overview of the product, notes on usage, and specifications. It also explains how to connect the product, configure the product, operate the product, perform maintenance on the product, and so on.

#### Communication Interface Manual

This document contains details about remote control. It is written for readers with sufficient basic knowledge of how to control testers and measuring instruments using SCPI commands.

#### Getting Started Guide

This document is intended for first-time users of the product. It provides only basic instructions. Please read this manual before you operating the product.

#### Safety Information

This document contains general safety precautions. Keep them in mind and make sure to observe them.

### Manual updates

This manual is subject to be revised due to product improvement and/or specification change. The latest manual (PDF and HTML) is available on our website.



<https://global.kikusui.co.jp/manual/>

### System versions that this manual covers

This manual applies to the products with the firmware of system version 1.0X.

For information on how to check the system version, see “Displaying the Device Information” ([p.158](#)).

When contacting us about the product, please provide us with the following information.

Model (marked in the top section of the front panel)

System version ([p.158](#))

Serial number (marked on the rear panel)

### Trademarks

Company names and product names in this manual are generally trademarks or registered trademarks of the respective companies.

### Copyright

Reproduction and reprinting of this operation manual, whole or partially, without our permission is prohibited.

Both unit specifications and manual contents are subject to change without notice.

© 2023 Kikusui Electronics Corporation

## Disposal

Dispose of PXT series in accordance with your local regulations.

## Open Source Software

This product contains open source software under the licensing terms of GNU General Public License (GPL), GNU LESSER General Public License (LGPL), and other licenses. For details, see the following URL.

<https://rddocuments.kikusui.co.jp/oss/pxt>

## Accessories

### Accessories for PXT20K-500

- [Q1-510-013] [M3-112-013] M3×8 (10 pieces)
- [Q1-510-035] (2 pieces) [M3-112-027] M4×10 (20 pieces)
- [B1-010-041] [B1-010-042] [B1-010-069] (2 pieces) [A8-930-056]
- AC INPUT terminal cover
- DC OUTPUT terminal cover
- [83-20-0290] [83-80-0340]
- External control connector kit (1 set)
- [M1-100-020] M10×25 (2 pieces) [M5-101-008] Spring washers (4 pieces)
- [M5-100-008] (4 pieces) [M4-100-008] (2 pieces)
- DC OUTPUT terminal screws (1 pair)
- [91-94-2901] [M3-112-027] M4×10 (1 piece)
- Chassis connection wire
- [83-70-1661]
- SENSING connector (2 pieces)
- Heavy object warning label (1 piece)  
When you move PXT series, be sure to put this sticker on a position where their contents can be seen. Make sure not to cover the air inlet and outlet with the sticker.
- Safety Information (1 copy)
- China RoHS sheet (1 copy)
- Getting Started Guide (1 copy)
- [P1-000-124] [M3-112-013] M3×8 (1 piece)
- EXT SYNC connector cover
- [P1-010-011] [M3-112-013] M3×8 (2 pieces)
- SENSING connector cover
- [96-00-0431] [91-80-9201]
- Synchronized operation signal cable kit

### Accessories for PXT20K-1000

- [Q1-510-013] [M3-112-013] M3×8 (10 pieces) [Q1-510-034] (2 pieces) [M3-112-027] M4×10 (20 pieces)
- [B1-010-041] [B1-010-042] [B1-010-069] (2 pieces) [A8-930-072]
- AC INPUT terminal cover
- DC OUTPUT terminal cover
- [M3-112-041] M5×10 (2 pieces)
- DC OUTPUT terminal screws (1 pair)
- [83-20-0290] [83-80-0340]
- External control connector kit (1 set)
- [M1-100-014] M8×25 (2 pieces) [M5-101-007] Spring washers (2 pieces)
- [M5-100-007] (4 pieces) [M4-100-007] (2 pieces)
- DC OUTPUT terminal screws (1 pair)
- [91-94-2901] [M3-112-027] M4×10 (1 piece)
- Chassis connection wire
- [83-70-1661]
- SENSING connector (2 pieces)
- Heavy object warning label (1 piece)  
When you move PXT series, be sure to put this sticker on a position where their contents can be seen. Make sure not to cover the air inlet and outlet with the sticker.
- Safety Information (1 copy)
- China RoHS sheet (1 copy)
- Getting Started Guide (1 copy)
- [P1-000-124] [M3-112-013] M3×8 (1 piece)
- EXT SYNC connector cover
- [P1-010-011] [M3-112-013] M3×8 (2 pieces)
- SENSING connector cover
- [96-00-0431] [91-80-9201]
- Synchronized operation signal cable kit

Accessories for PXT20K-1500

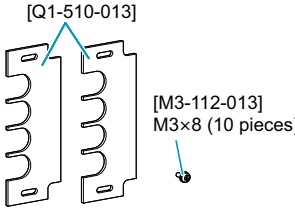
- 

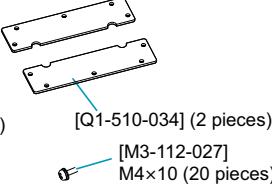
AC INPUT terminal cover
- 

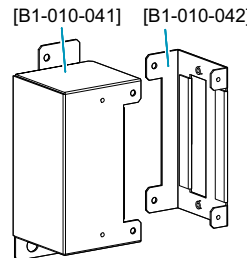
DC OUTPUT terminal cover
- 

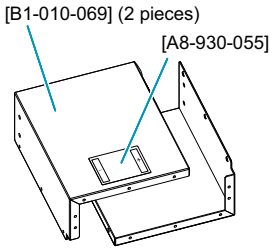
AC INPUT terminal cover
- 

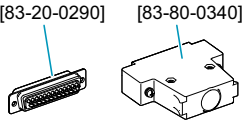
DC OUTPUT terminal cover
- 

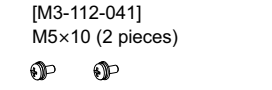
External control connector kit (1 set)
- 

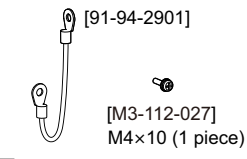
DC OUTPUT terminal screws (1 pair)
- 

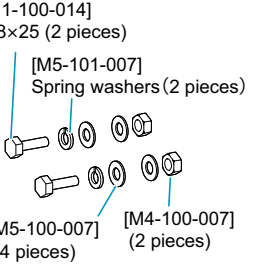
Chassis connection wire
- 

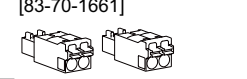
DC OUTPUT terminal screws (1 pair)
- 

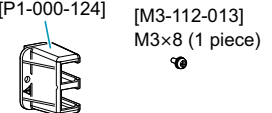
SENSING connector (2 pieces)
- 

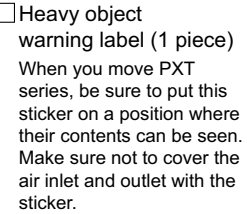
EXT SYNC connector cover
- 

Heavy object warning label (1 piece)  
When you move PXT series, be sure to put this sticker on a position where their contents can be seen. Make sure not to cover the air inlet and outlet with the sticker.
- 

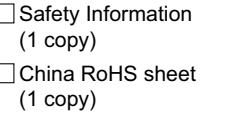
SENSING connector cover
- 

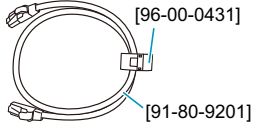
Safety Information (1 copy)  
 China RoHS sheet (1 copy)
- 

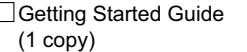
Synchronized operation signal cable kit
- 

Getting Started Guide (1 copy)

## Product Overview

The PXT series are a Regulated dc power supply designed to offer the highest levels of reliability and safety.

### Model configurations

Model	Input voltage rating	Output rating		
		Power	Voltage	Current
PXT20K-500	200 V	20 kW	500 V	120 A
	400 V	20 kW	500 V	120 A
PXT20K-1000	200 V	20 kW	1000 V	60 A
	400 V	20 kW	1000 V	60 A
PXT20K-1500	200 V	20 kW	1500 V	30 A
	400 V	20 kW	1500 V	30 A

### Features

In addition to basic constant current, constant voltage, and constant power modes, this product offers a variety of other functions.

#### Equipped with touch panel display

You can operate this intuitively by pressing the display. The pressure-sensitive panel allows you to operate it with your gloves on.

#### Interface available with external expansion

Connecting with LAN, USB, RS232C, and external analog control are set default.

#### Realizing a compact but large-capacity power system

20 kW power in a single 3U-size housing is realized.

#### Highly flexible external digital control

5 input terminals and 6 output terminals are provided for free function selection. The signal input and output are non-polar.

#### Equipped with slew rate switching and response switching

Optimal test condition is provided according to the application.

## Notations Used in This Manual

### In-Text notations

- In this manual, units of Regulated dc power supply PXT20K-500, PXT20K-1000, and PXT20K-1500 refer to as “PXT series”
- In this manual, constant voltage, constant current, and constant power may refer to as CV, CC, and CP, respectively.
- “PC” in this manual is a generic term for personal computers and workstations.
- The term “DUT” is used to refer generally to a device under test.
- “>” indicates the hierarchy of items you need to select. The item to the left of this symbol indicates a higher level item.
- The screen captures and illustrations used in this manual may differ from the actual items.

### Safety information

#### WARNING

Indicates a potentially hazardous situation which, if ignored, could result in death or serious injury.

#### CAUTION

Indicates a potentially hazardous situation which, if ignored, may result in slight injury or damage to the product and other property.

#### NOTE

Indicates information that you should know.

## Safety Precautions

When using this product, be sure to observe the precautions in the Safety Information Manual. Items specific to this product are given below.

### When using in general

#### WARNING

- **Wear earplugs when working near PXT series when it is running.**  
The noise sound pressure level of PXT series is 80 dB or less, however, when PXT series is operated in the same place as other equipment with a large noise sound pressure level or when plural units of PXT series are operated simultaneously in the same place, make sure to take measures to prevent hearing loss. The noise sound pressure level near PXT series may exceed 80 dB.

## Installation

### ⚠ CAUTION

- **Do not install the product in residential environment.**  
PXT series is not intended for use in residential environments and may not provide adequate protection to radio reception in such environments.
- **Keep distance of 50 cm or more from the air outlet.**  
Stay away from the exhaust because it can get hot. The air outlet of the PXT series should be away from the wall or objects installed so that the exhaust air does not directly hit the wall or objects installed.
- **Work with two or more people when lifting or moving PXT series.**  
Be careful not to pinch your fingers and/or hands while working.

## Terminal cover

### ⚠ WARNING

Risk of electric shock.

- Before turn the **POWER** switch on, make sure that the included **SENSING** terminal cover and **DC OUTPUT** terminal cover are attached.
- Do not attach a terminal cover other than the included ones.

## Connection

### ⚠ WARNING

Risk of electric shock.

- Do not touch **DC OUTPUT** terminal when the output is turned on.
- Do not connect **DUT** to the **DC OUTPUT** terminal while the output is on.
- Do not approach or place non-isolated objects within 5 cm of the load cables when the output is turned on.
- Before you connect the power cable, turn off the switchboard breaker (a switch that cuts off the power supply from the switchboard).
- Connect the protective conductor terminal to earth ground.  
PXT series is IEC Safety Class I equipment (equipment with a protective conductor terminal). Ground the product to prevent electric shock.
- Have a qualified engineer make the connection to the switchboard.
- After connecting **PXT** series to the switchboard, attach the **AC INPUT** terminal cover.
- For load cables, use cables whose rated voltage is higher than the isolation voltage of **PXT** series.

Risk of fire.

- Use load cables having strong flame-resistant insulation with sufficient margin for the current.

### ⚠ CAUTION

- When connecting **PXT** series to the switchboard, be sure to match polarities (**R**, **S**, **T** and  $\oplus$  (Protective conductor terminal)).  
Inside **PXT** series, protection circuits are connected to match the **AC INPUT** terminal.

Risk of overheating.

- Use appropriate crimping terminals and the included screw set to connect the load cables.

Risk of damage to **DUT**.

- Make sure to connect with the correct polarities.  
If you connect with reversed polarity, overcurrent will flow through the diode inside the **PXT** series regardless of the output **ON/OFF**.

**DUT** or **PXT** series may be damaged.

- To connect **PXT** series with **DUT** that generates reverse current, connect a resistor with the sufficient rated power to bypass the reverse current. (p.27)

This may shorten the life of the **DUT** or damage **PXT** series.

- To connect **PXT** series with **DUT** with accumulated energy, connect a reverse-current-protection diode (**DRP**) between the **PXT** series and the **DUT** in series. (p.28)

## Power on and off

### ⚠ WARNING

Risk of electric shock.

- Before turn the **POWER** switch on, make sure that the **DC OUTPUT** terminal cover and **Sensing** terminal cover are attached.

### ⚠ CAUTION

- If you notice strange sounds, unusual odors, fire, or smoke around or from inside **PXT** series, turn **POWER** switch off.

## Residual voltage

### ⚠ WARNING

Risk of electric shock.

- If any residual voltage exists, do not touch the **DC OUTPUT** terminal until the residual voltage is discharged.  
For the conditions under which residual voltage occurs and the discharge time, refer to "Guide for Required Time for Residual Voltage Discharge" (p.193).
- If you turn off the **POWER** switch due to a **HIGH** alarm, do not touch the **DC OUTPUT** terminal.  
A residual charge may exist in the **DC OUTPUT** terminal. For more information on the required time for the discharge, refer to "Guide for Required Time for Residual Voltage Discharge" (p.193).
- When the settings of the bleeder is disabled, do not touch the **DC OUTPUT** terminal. (p.44)  
When the bleeder is set to disabled, the voltage existed when the output was on remains in the output terminal even after you turn the output or **POWER** switch off.

## Remote sensing

### WARNING

Risk of electric shock.

- Do not connect cables to the SENSING terminals while the POWER switch is turned on.
- For SENSING cables, use cables whose rated voltage is higher than the isolation voltage of PXT series.  
Recommended wiring: UL3239; Rated voltage 3 kV
- Make sure not to have the conductor of the cable touch the chassis when connecting.
- Before turn the POWER switch on, make sure that the Sensing terminal cover is attached.

### CAUTION

PXT series and DUT may be damaged.

- Securely connect wires of the designated wire diameter to the SENSING terminals.  
Make sure that wiring is not disconnected during remote sensing.

## Parallel operation

### CAUTION

PXT series and DUT may be damaged.

- Do not leave one end of the parallel operation signal cable connected to the PARALLEL connector when the other end is not connected.
- Do not perform standalone operation with the parallel operation signal cable left connected to the PARALLEL connector.

## External control

### CAUTION

PXT series and DUT may be damaged.

- Do not input voltages outside the control voltage range to the analog input terminal and digital input terminal.  
For the input specifications, refer to "External Control Specifications" (p.184).

## Cleaning

### WARNING

Risk of electric shock.

- Turn the POWER switch off, and turn the switch of the switchboard off.

## Disposal

### WARNING

Risk of electric shock.

- To remove the power cord from the switchboard, turn the switch of the switchboard off.

Risk of rupture or ignition.

- Do not short-circuit, charge, disassemble, deform, throw into fire, or overheat the built-in battery.

## Notes on Usage

When using or storing this product, be sure to observe the temperature and humidity ranges. For environmental conditions, see General Specifications (p.188).

# Component Names



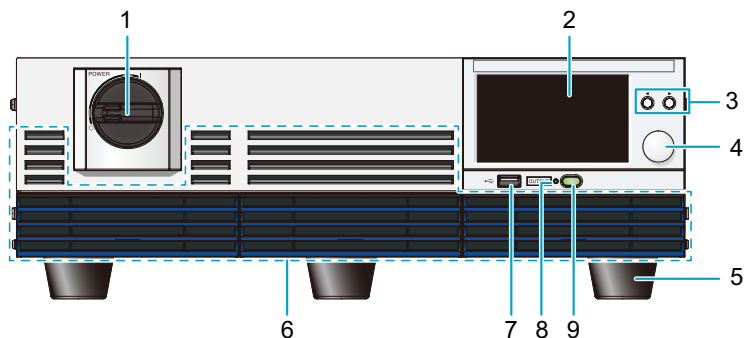





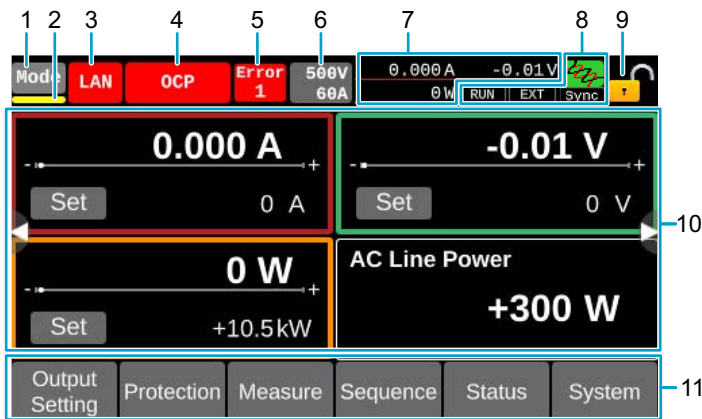





## Front Panel



Number	Name	Description
1	POWER switch	Turning the handle to the I side turns the power on, and the O side turns it off. (p.24)
2	Touch panel display	Display the settings, measured values, and other information. Use the touch panel to operate. (p.35)
3	◀ and ▶ keys	Move the cursor left and right. Select the left and right items. (p.39)
4	Rotary knob	Select items. Input numbers and characters. (p.39)
5	Foot	5 locations on bottom panel. Remove them when installing in a rack. (p.199)
6	Air inlet	Air inlet for cooling.
7	USB port (host)	This port is used to connect an save and load setup memory (p.99), save and load programs (p.125), and update the firmware (p.166). Connecting a mouse allows you to operate the display. (p.35)
8	OUTPUT LED	Light when the output is on. Blink during discharge. (p.40)
9	OUTPUT key	Switch on/off of the output from the DC OUTPUT terminal. (p.40) Stops the sequence. (p.124)

# Touch Panel Display (Homepage)



Number	Name	Description
1	Operation mode	While the output from the DC OUTPUT terminal is on, the present operation mode is displayed. Press this icon when the output is off to set the preferred operation mode. (p.43)   CV: Constant voltage mode,  CC: Constant current mode,  CP: Constant power mode
2	Delay in output on	Display a blinking yellow mark during the output ON/OFF delay time. (p.75)
3	LAN status	Display the LAN connection status. Green: Communication enabled, Orange: Preparing for communication, Red: Not connected. Press this icon to display the communication setting. (p.149)
4	Alarm information	Turn red when an alarm is sounding and displays the alarm name. If two or more alarms are occurring simultaneously, "Many" is displayed. Press this icon to display the alarm screen. (p.68)
5	SCPI error information	The error icon is displayed when an SCPI error is occurring. The number of error incidents (up to 16) is displayed numerically. Press this icon to display the error information. (p.170)
6	Rated value	The rated values of the output current and output voltage are displayed. Press this icon to display the device information. (p.158)
7	Measured value	The output voltage, output current, and output power are displayed. Press the measured value to enlarge the display.
8	Sequence/external control/Sensing connection/synchronized operation status	 RUN The sequence is running. (p.105)  EXT Digital input/output for external control is enabled. (p.139)  Sensing function is enabled. (p.70)  Sync Synchronized operation is valid. (p.85)
9	Key lock status	 Key lock is released. Press and hold to enable the key lock. (p.159)  Indicate that key lock is on. The lock level is indicated with a number (p.159).  Press and hold to release the key lock.   Indicate that key lock is on. This is indicated on key-locked slave units during parallel operation. Press and hold the icon to release the key lock.  The key is locked by the RLST command under remote control. The lock can be released by pressing and holding the icon in some cases. (p.160)  The key is locked by the RLST command under remote control. You cannot release the lock by panel operation. (p.160)  The key is locked by the status of remote control. You cannot release the lock by panel operation. (p.160)
10	Measured value / Set value	Measured value / Set value are displayed. (p.41)
11	Menu	Press a button in Menu to move to the screen of each function. (p.36)

## Rear Panel

The position of each part is the same for all models.

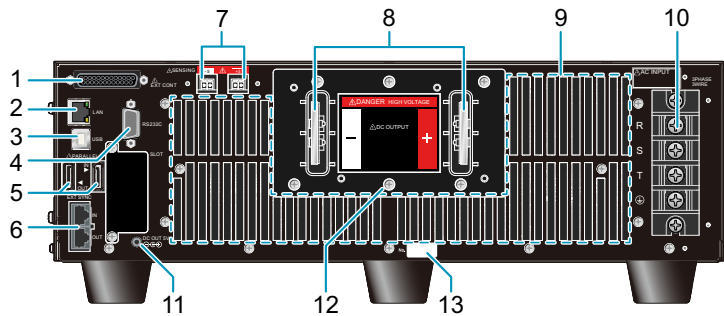

Number	Name	Description
1	EXT CONT connector	This connector is used for external control. When the product is shipped from the factory, covers are attached to the terminals. <a href="#">(p.127)</a>
2	LAN port	This connector is used for remote control. For details, see the Communication Interface Manual.
3	USB port	
4	RS232C port	
5	PARALLEL connector	This connector is used for parallel operation. <a href="#">(p.90)</a>
6	EXT SYNC connector	This connector is used for synchronized operation. A cover is attached. <a href="#">(p.85)</a>
7	SENSING terminals	These terminals are used for remote sensing. Connect the included SENSING connector. A cover is attached. <a href="#">(p.70)</a>
8	DC OUTPUT terminal	These terminals are used to connect the DUT and the product. A cover is attached. <a href="#">(p.27)</a>
9	Air outlet	Air outlet for cooling.
10	AC INPUT terminal block	This connector is used to connect the power cord. A cover is attached. <a href="#">(p.16)</a>
11	DC OUT 5V connector	This connector is used during GPIB converter (option) use. <a href="#">(p.200)</a>
12	Chassis terminal	A connector for grounding the output. <a href="#">(p.29)</a>
13	Serial number	The product's serial number.

# Preparation

This chapter describes how to prepare the PXT series for use.

- For information about installing and moving the PXT series, see “Precautions Concerning Installation Location” and “Precautions to Be Taken When Moving the Product” in the Safety Information Manual.
- When using or storing the PXT series, be sure to observe the temperature and humidity ranges. For environmental conditions, see “General Specifications” (p.188).
- If you want to mount the product on a rack, see “Rack mount bracket” (p.199).

## Connecting the Power Cord

### WARNING

**Risk of electric shock.**

- **Before you connect the power cable, turn off the switchboard breaker (a switch that cuts off the power supply from the switchboard).**
- **Connect the protective conductor terminal to earth ground.**  
PXT series is IEC Safety Class I equipment (equipment with a protective conductor terminal). Ground the product to prevent electric shock.
- **Have a qualified engineer make the connection to the switchboard.**
- **After connecting PXT series to the switchboard, attach the AC INPUT terminal cover.**

### CAUTION

**When connecting PXT series to the switchboard, be sure to match polarities (R, S, T and ⊕ (Protective conductor terminal)).**

Inside PXT series, protection circuits are connected to match the AC INPUT terminal.

### NOTE

- The POWER switch of the product can be used to disconnect the product from the AC line in an emergency. Provide adequate space around the POWER switch so that the POWER switch can be turned off at any time.
- We recommend that you use one of the optional specialized power cords to connect to the AC power line. If you will not use one of these power cords, use an appropriate power cord with a length of 3 m or less that has been selected by a qualified technician.

This product is designed as an equipment of IEC Overvoltage Category II (energy-consuming equipment supplied from a fixed installation).

Connection example are described below.

Example of 3P3W (200 V or 400 V input)

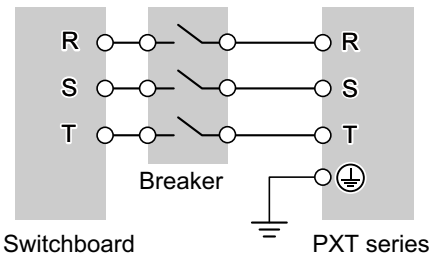

Example of 3P4W (400 V input)

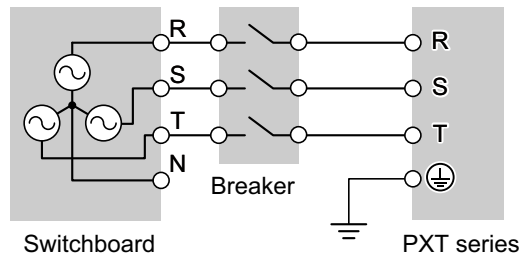

## Preparing for connection

### Preparing power cord

A power cord is not included with this product. Optional three-phase input power cords ([p.198](#)) are available. If you do not use the optional power cords, use ones with a nominal cross-sectional area of 22 mm<sup>2</sup> or more.

The power cord can be drawn out to the lateral side or rear-panel side of the main unit.

If you pull out the power cords to the side, use ones with a crimping terminal compatible with R22-S6 on one end to be connected to the AC INPUT terminal. (The optional power cords are equipped with such a crimp terminal.)

If you pull out the power cords to the rear side, you need to bend them, which may cause damage to them. We recommend using a right-angle terminal compatible with R22-S6 to connect the cords to the AC INPUT terminal.

### Checking the distribution system

The following distribution systems are available. Make sure that the distribution system to be connected falls within the scope.

Distribution system	Nominal voltage	Allowable variation range	Note
Three-phase three-wire	200 Vac to 240 Vac	180 Vac to 252 Vac	Interphase voltage = Line voltage
	380 Vac to 480 Vac	342 Vac to 504 Vac	Interphase voltage = Line voltage
Three-phase four-wire	380 Vac to 480 Vac	342 Vac to 504 Vac	Interphase voltage $\times \sqrt{3}$ = Line voltage Neutral line is not used.

### When using breaker

Use a circuit breaker that meets the requirement below:

Input specifications for PXT series	Nominal current	Current sensitivity
200 Vac input	100 A or less	15 mA or more
400 Vac input	50 A or less	30 mA or more

## Connecting the power cord

Make sure to attach the included AC INPUT terminal cover on the AC INPUT terminal block. The power cords can be pulled out in two different directions according to the installation environment.

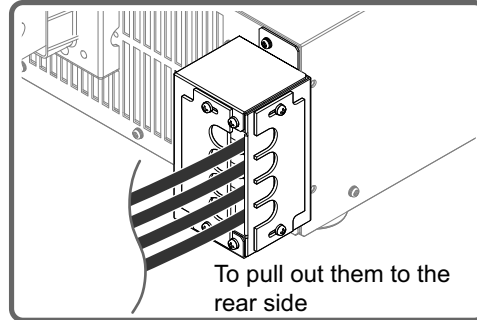
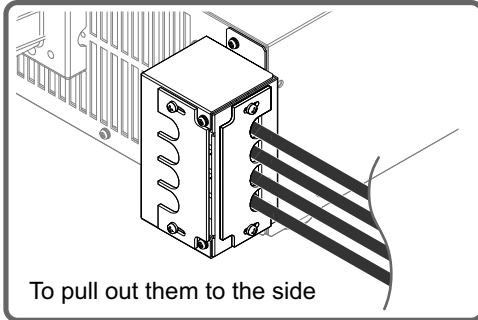

### 1 Check that the AC power line meets the nominal input rating of the product.

Acceptable input voltage (any nominal supply voltage in the following ranges):

200 Vac input model: 200 Vac to 240 Vac

400 Vac input model: 380 Vac to 480 Vac

The supported frequencies are 50 Hz and 60 Hz. (Frequency range: 47 Hz to 63 Hz)

### 2 Turning the POWER switch off (O).

### 3 Connect the power cords with R, S, T, and ⊕ (Protective conductor terminal) of the AC INPUT terminal block.

Tightening torque: 2.5 N·m

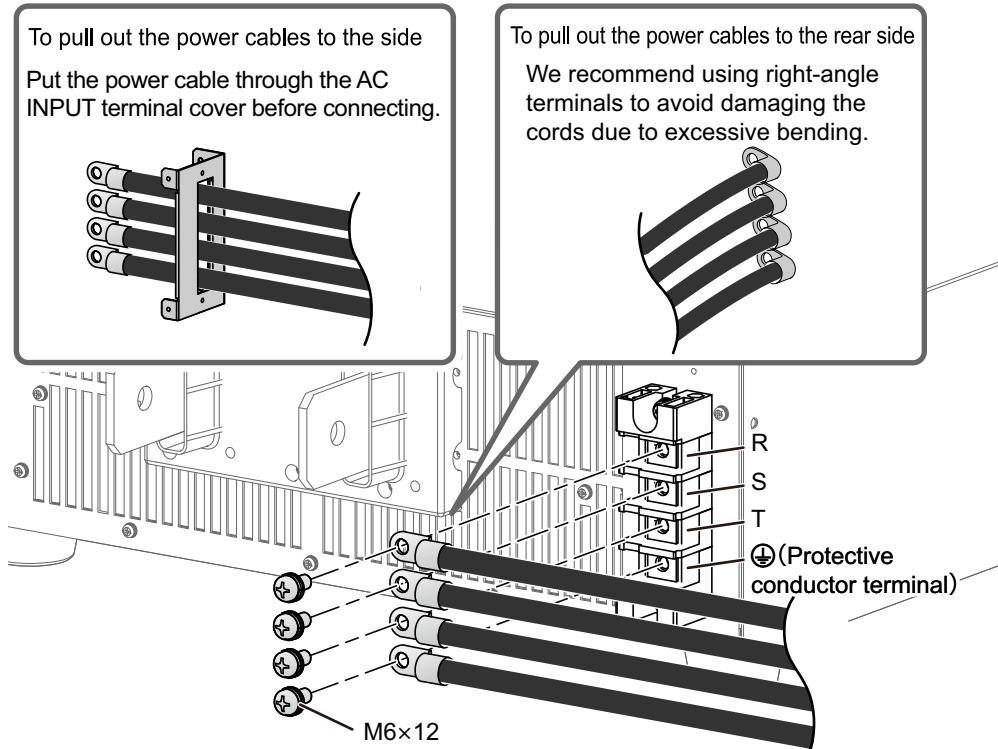

**4 Attach the side-panel AC INPUT terminal cover.**

Set the cover as shown in the drawings according to the direction where the power cords are pulled out.

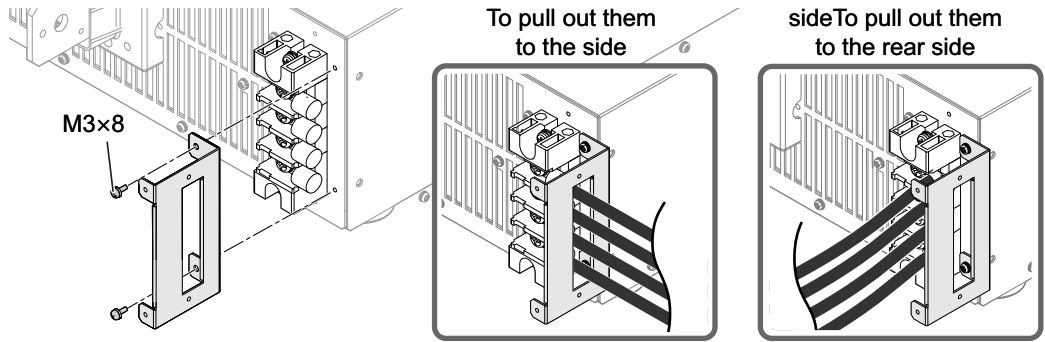

**5 Attach the rear-panel AC INPUT terminal cover.**

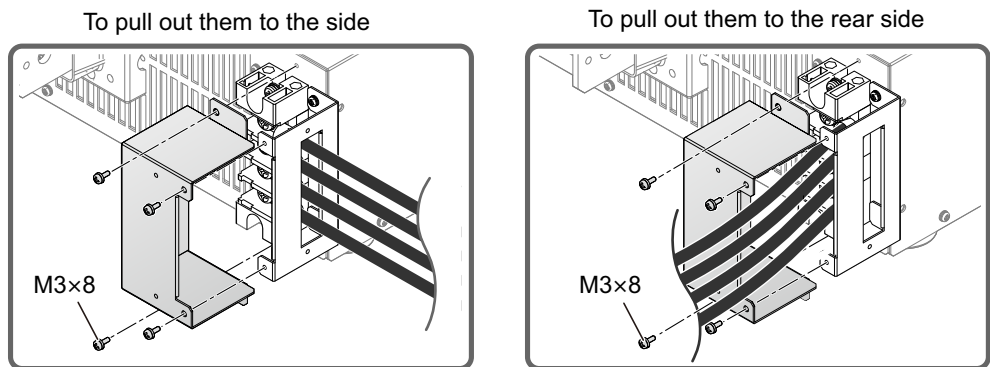

**6 Attach the protection plate.**

The direction of the protection plate differs depending on the direction where the power cords are pulled out. Make sure to prevent your fingers from being caught in the AC INPUT terminal cover when attaching the protection plate.

To pull out them to the side

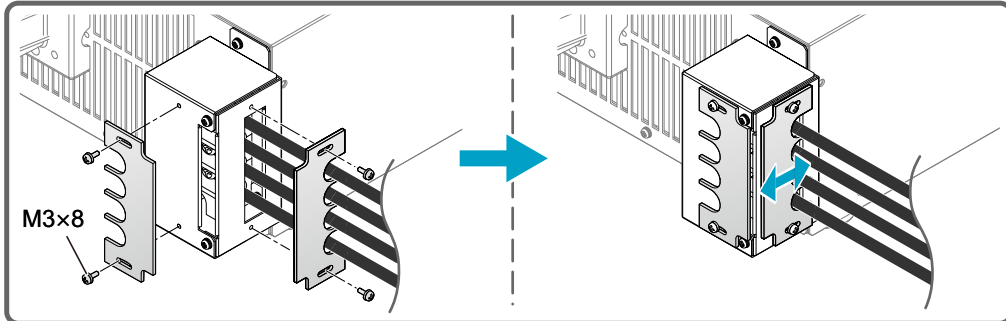

To pull out them to the rear side

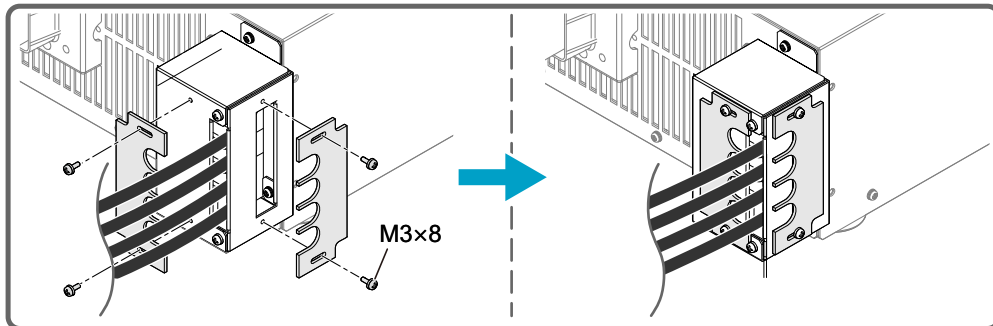

**7 Attach a crimping terminal that matches the terminal screw of the circuit breaker to the breaker side of the power cord.**

**8 Turn off the switchboard's circuit breaker.**

**9 Connect the power cords with R, S, and T of the circuit breaker and ground ⊕ (Protective conductor terminal).**

This completes the connections.

## Attaching the Terminal Cover

For the safety, attach the included covers to the DC OUTPUT terminal and the SENSING terminal before turning ON the power supply of the PXT series.

### WARNING

Risk of electric shock.

- Before turn the **POWER** switch on, make sure that the included **SENSING** terminal cover and **DC OUTPUT** terminal cover are attached.
- Do not attach a terminal cover other than the included ones.

## Attaching the SENSING terminal cover

Attach the included SENSING terminal cover referring to the figure below. The following figure shows an example of PXT20K-1500.

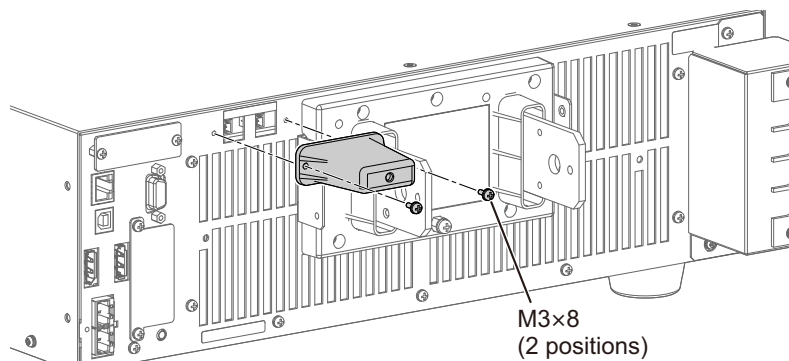

## Attaching the DC OUTPUT terminal cover

There are two types of the DC OUTPUT terminal cover, the top side and the bottom side. The cover with the polarity sticker on it is the top side. Each model has its unique shape, however, the number of screws and positions to attach the DC OUTPUT terminal cover are the same.

Top half of the cover

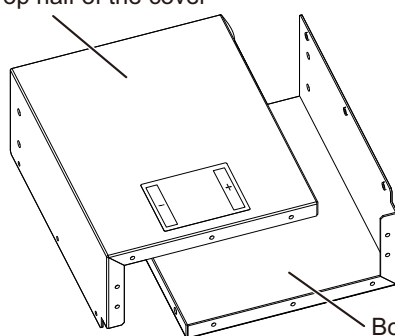

Bottom half of the cover

The procedure is explained using PXT20K-1500 as an example.

**1 Attach the bottom half of the DC OUTPUT terminal cover.**

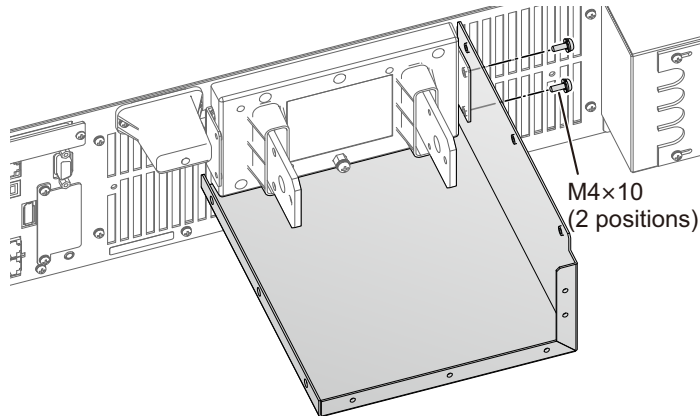

**2 Attach the top half of the DC OUTPUT terminal cover.**

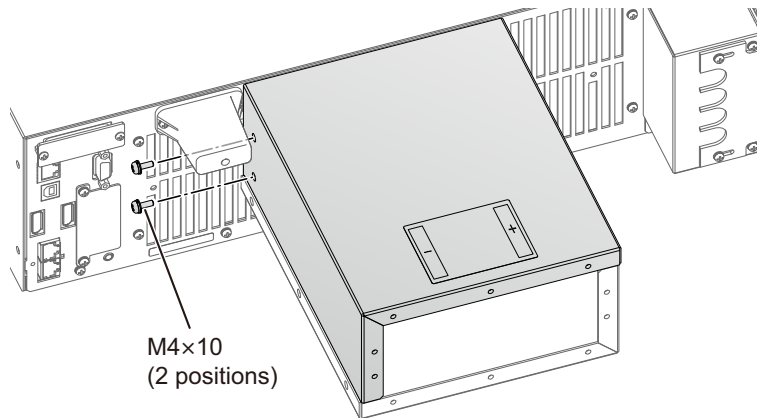

**3 Fix the DC OUTPUT terminal covers on both sides.**

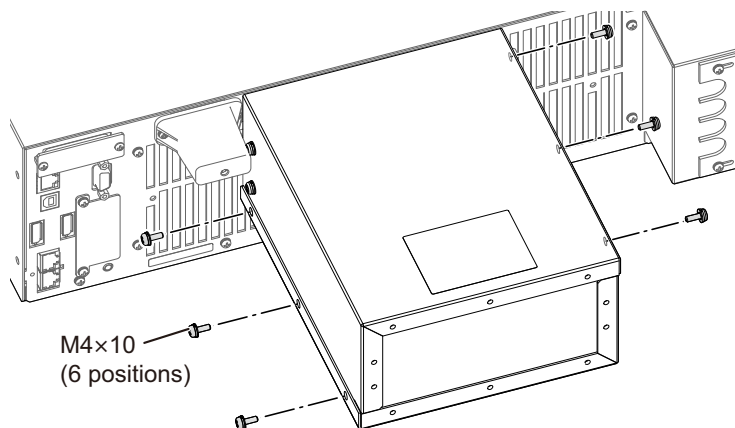

**4** Attach the protection plate to the DC OUTPUT terminal cover.

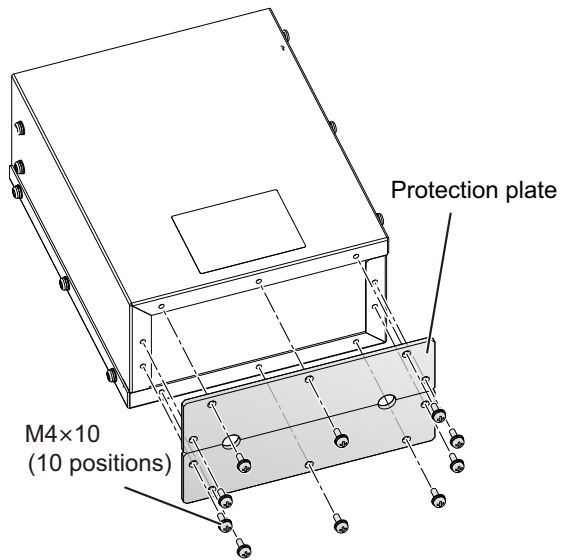

This completes the installation.

# Checking Whether the Power is On or Off

## Turning the power on

### **⚠ WARNING**

Risk of electric shock.

- Before turn the POWER switch on, make sure that the DC OUTPUT terminal cover and Sensing terminal cover are attached. (p.21)

### **⚠ CAUTION**

If you notice strange sounds, unusual odors, fire, or smoke around or from inside PXT series, turn POWER switch off.

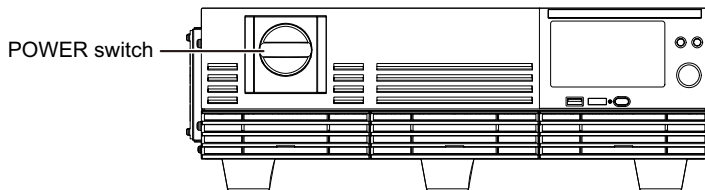

**1** Check that the power cord is connected properly.

**2** Turn the POWER switch on (I).

Power turns on, and the model name and system version are displayed.

Then, the Homepage is displayed.

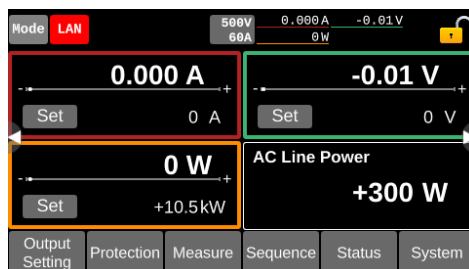

When the power is turned on for the first time for this product, it gets activated in the factory default conditions. For the second time or after, the product gets activated with the panel settings applied immediately before the POWER switch was turned off.

The panel setting state at startup can be changed (p.76).

The output state at startup can be changed (p.77).

## Turning the power off

- 1 Turn the **POWER** switch off (O).  
Caution on residual voltage appears, then the power turns off.

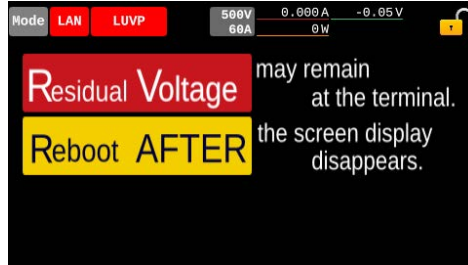

### NOTE

- Although the LUVP alarm occurs in the external or remote control when the power turns off, it is not an error.
- If you want to turn the **POWER** switch back on, wait at least 10 seconds after the fan stops. Repeatedly turning the **POWER** switch on and off at short intervals will shorten the service life of the **POWER** switch and the internal input fuse.

# Setting the Date/Time

Set the year, month, day, and time. If connecting to an NTP server over a LAN, refer to “Retrieving the time from an NTP server” (p.163).

## 1 Press System on the homepage.

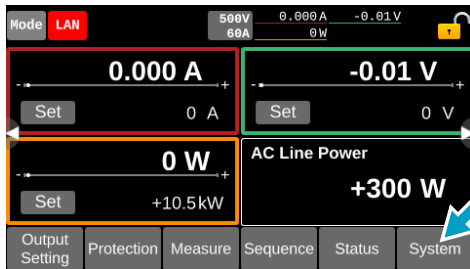

## 2 Swipe to the left, or press the ► key, till Date Config is displayed.

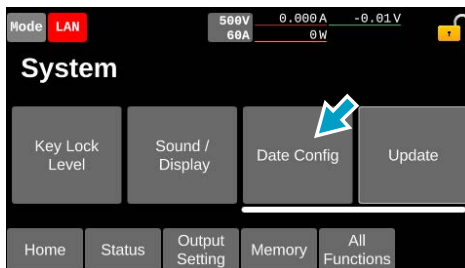

The date/time setup screen appears.

## 3 Press Manual Time.



## 4 Set the year, month, day, and time.

Press ↑ and ↓ to set the number.



Setting range: 2022-1-1 0:00 to 2037-12-31 23:59

## 5 Press Apply.

This completes the setting.

# Connecting to the DUT

## Output destabilizing DUT

Note that the output may become unstable if the following types of DUT are connected. To stabilize the output, measures are necessary depending on the type of DUT.

### DUT with peak current or pulse-shaped current

The ammeter on PXT series indicates the average value. Even when the indicated value is less than or equal to the set constant current, the peak value may exceed the set constant current. If this happens, PXT series is instantaneously put into the constant-current mode, and the output voltage drops. For those DUT with peak current or pulse-shaped current, increase the set output current value or current capacity.

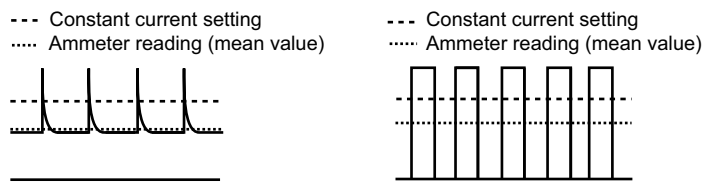

### DUT that generates reverse current to the power supply

#### ⚠ CAUTION

**DUT or PXT series may be damaged.**

- To connect PXT series with DUT that generates reverse current, connect a resistor with the sufficient rated power to bypass the reverse current.

PXT series cannot absorb reverse current from DUT. If a regenerative DUT (such as an inverter, converter, or transformer) is connected, the output voltage increases and the output becomes unstable. This can cause a malfunction.

For those DUT that generate reverse current to the power supply, connect a resistor ( $R_D$ ) as shown in the following figure to bypass the reverse current. However, the amount of current to the DUT decreases by  $I_{rp}$ .

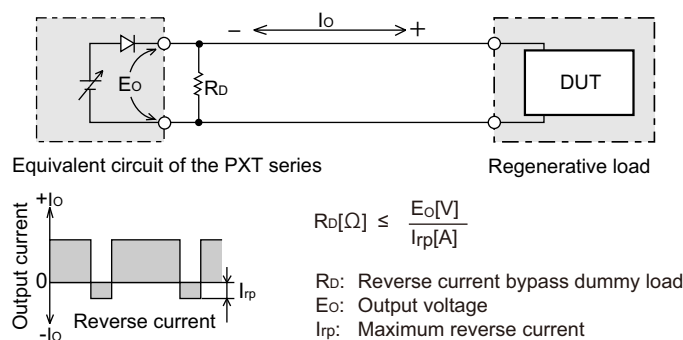

## DUT with accumulated energy

### CAUTION

This may shorten the life of the DUT or damage PXT series.

- To connect PXT series with DUT with accumulated energy, connect a reverse-current-protection diode (DRP) between the PXT series and the DUT in series.

When connecting DUT with accumulated energy, such as a battery, current will flow from the DUT to the internal circuit of PXT series, which may damage the PXT series or reduce the life of the DUT.

For those DUT with accumulated energy, connect a reverse-current-protection diode (DRP) between the PXT series and the DUT in series as shown in the following figure. This cannot be used in conjunction with remote sensing.

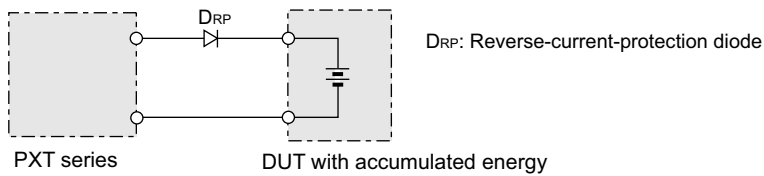

## Grounding the DC OUTPUT terminal

To ground the output terminal, connect the chassis terminal to the – or + terminal of DC OUTPUT with the included chassis connection wire.

### NOTE

- When the chassis terminal is connected to the + terminal of DC OUTPUT, do not output a voltage exceeding the isolation voltage ([p. 188](#)). This may damage PXT series.
- When grounding the DC OUTPUT terminal, do not ground the DUT.

- 1** Turn OFF the output of the PXT series and remove the DC OUTPUT terminal cover from the DC OUTPUT terminal.
- 2** Connect the chassis connection terminal to the – or + terminal of DC OUTPUT with the included chassis connection wire.

Tightening torque: 1.33 N·m

The following figure shows an example of connecting to the –terminal.

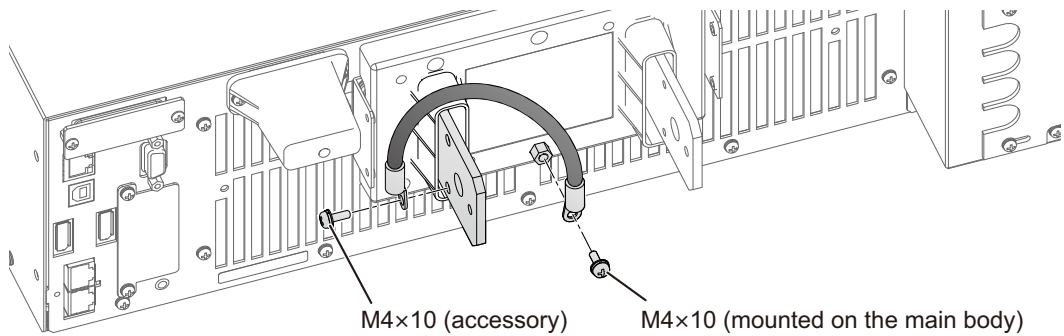

This completes the connections.

## Connecting the DUT

For details on selecting a load cable, refer to “Appendix” “Selecting the Load Cables” (p.192) in the Appendix. Load cables are available as options (p.198).

### WARNING

#### Risk of electric shock.

- Do not touch DC OUTPUT terminal when the output is turned on.
- Do not connect DUT to the DC OUTPUT terminal while the output is on.
- Do not approach or place non-isolated objects within 5 cm of the load cables when the output is turned on.
- Before turn the POWER switch on, make sure that the DC OUTPUT terminal cover and Sensing terminal cover are attached.

### CAUTION

#### Risk of damage to DUT.

- Make sure to connect with the correct polarities.

If you connect with reversed polarity, overcurrent will flow through the diode inside the PXT series regardless of the output ON/OFF.

#### Risk of overheating.

- Use appropriate crimping terminals and the included screw set to connect the load cables.

**1** Turn OFF the output of the PXT series and remove the DC OUTPUT terminal cover from the DC OUTPUT terminal.

**2** Attach crimping terminals to the load cables.

The DC OUTPUT terminals have holes for connecting the load cables. Attach the appropriate crimping terminals to the cables.

Model	Bolt or screw size
PXT20K-500	M10 × 25
PXT20K-1000, PXT20K-1500	M5 × 10, M8 × 25

### 3 Connect the load cables to the DC OUTPUT terminals using the included screw set for DC OUTPUT terminals.

■ For PXT20K-500

Tightening torque: 22.46 N·m

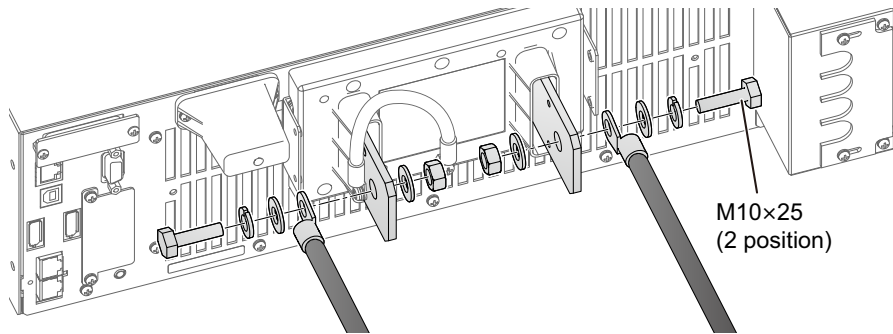

■ For PXT20K-1000 or PXT20K-1500

Tightening torque

M5: 2.61 N·m

M8: 11.22 N·m

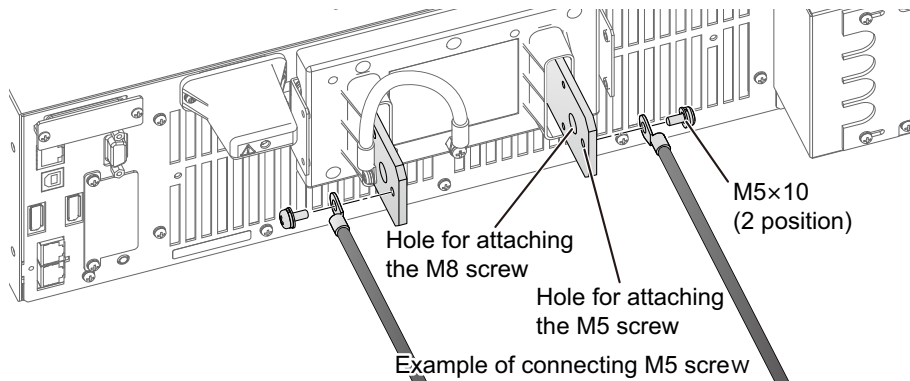

### 4 Attach the included bottom half of the DC OUTPUT terminal cover.

Make sure the cover without the polarity sticker is on the bottom side.

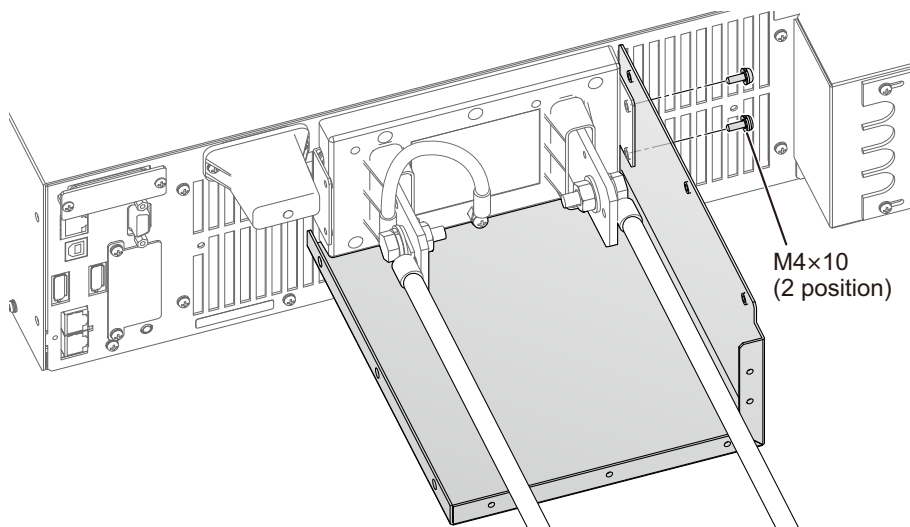

**5** Attach the top half of the DC OUTPUT terminal cover.

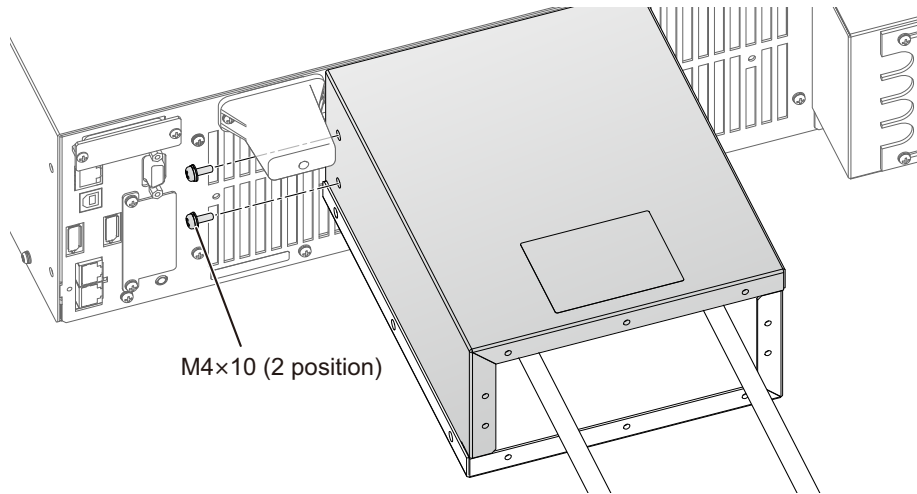

**6** Fix the DC OUTPUT terminal covers on both sides.

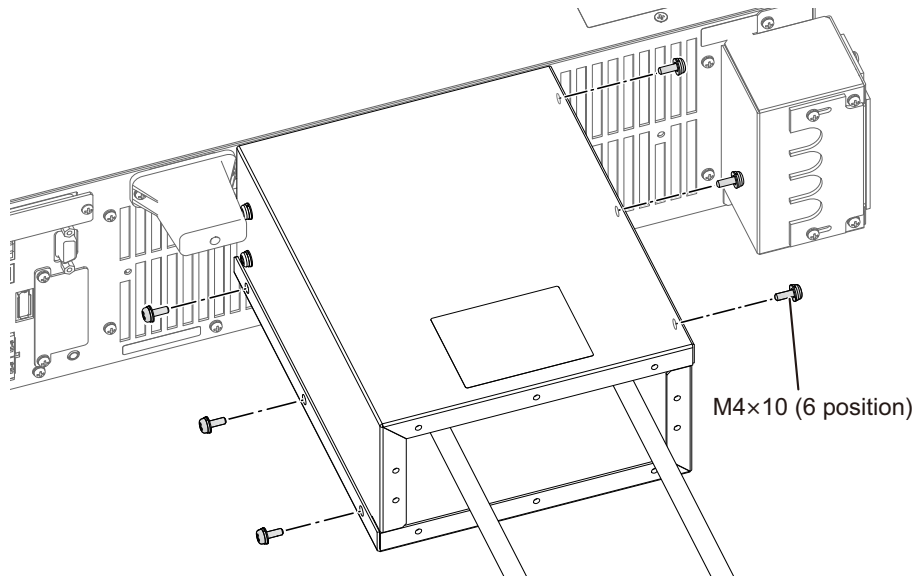

## 7 Attach the included protection plate to the DC OUTPUT terminal cover.

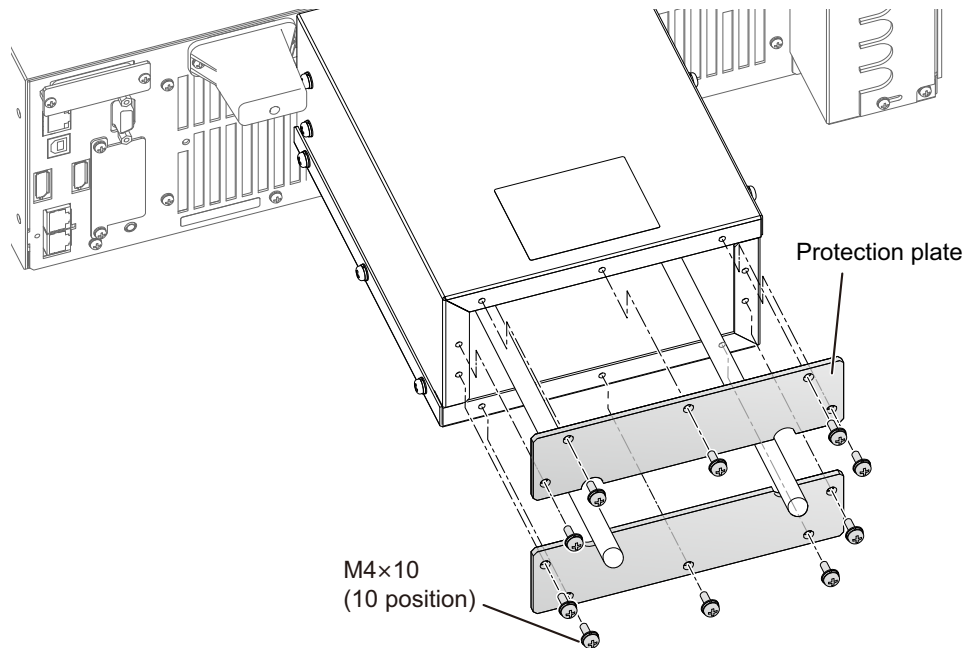

## 8 Connect the load cables to the DUT.

Be careful to match the polarities of the DC OUTPUT terminals with those of the DUT terminals during connection.

Use the shortest cables possible to connect the product and DUT, and twist the cables. If the cables are too thick to be twisted, bring the DC OUTPUT terminal's positive and negative terminal cables close together and make them parallel.

This completes the connections.

# Basic Operation

## Operating Area

Operation area of PXT20K-500

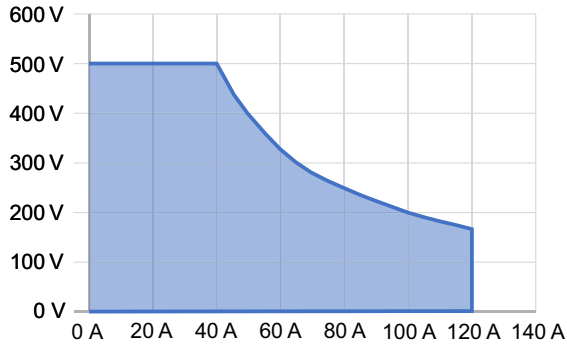

Operation area of PXT20K-1000

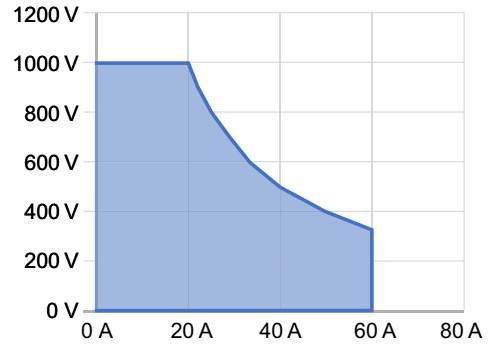

Operation area of PXT20K-1500

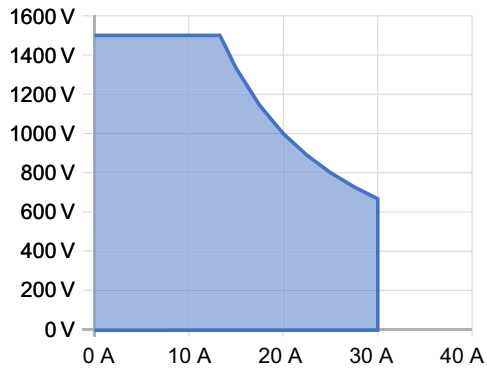

# Touch Operation

The touch-panel display (hereinafter “display”) can be operated by touch to display menus and change values. By connecting a mouse to the USB connector on the front panel, you can also operate with a mouse.

In this document, we explain the touch operation.

## Touch operation

The display is a pressure-sensitive type, which allows you to operate it even when wearing gloves. Use your finger to push down the target items on the display. Press and hold for 1 second or more to give a long press.

Instead of the swipe operation, using the ◀ / ▶ keys on the front panel is also available.

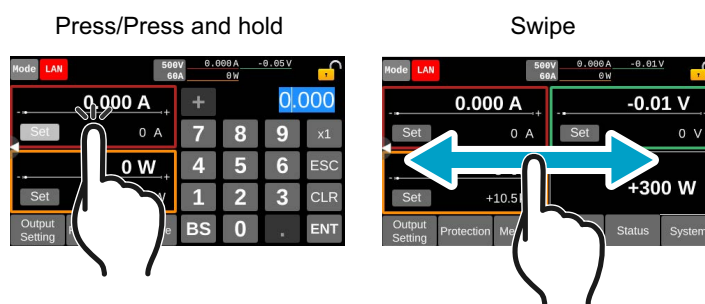

## Mouse operation

By connecting a mouse to the USB connector on the front panel, a mouse cursor appears on the display. With a left mouse click, you can select an item displayed on the screen or set a number.

When dragging with the mouse, you can perform an action equivalent to a swipe by touch. Press and hold the left mouse button for 1 second or more for a long press.

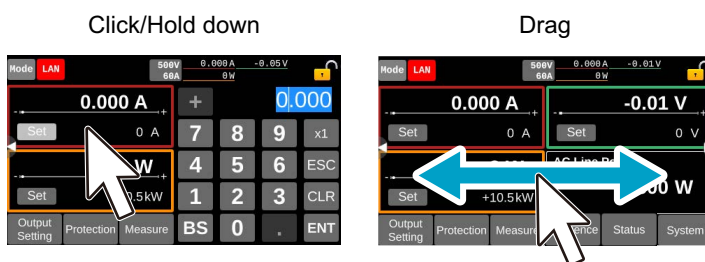

## Displaying the menu

Press the menu button shown at the bottom of the display to indicate the menu for each function. When there is a menu not fully displayed, swipe the menu to the left or press the ► key on the front panel to scroll the screen.

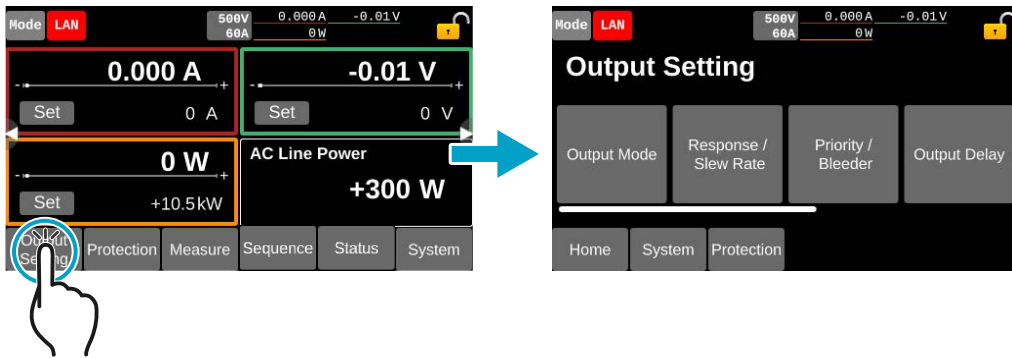

### ■ Displaying all functions available in the menu

When All Functions at the bottom of the System menu is pressed, all menus are displayed.

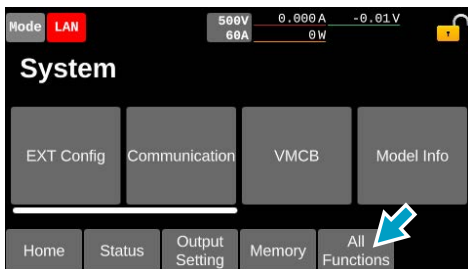

## Menu reference

Menu		Available operations
Output Setting	Output Mode	Setting the Output Mode (p.46)
	Response / Slew Rate	Set the response (p.73) and slew rate (p.74)
	Priority / Bleeder	Set the priority operation mode (p.43) and the Bleeder (p.44)
	Output Delay	Setting Output Delay (p.75)
	I-V List	Setting the I-V list function (p.78)
	IR	Set the internal resistance function (p.83)
	Synchronize	Synchronized operation of output (p.85)
Protection	–	Set the protection function (p.58)
Measure	Measure Config	Set the measurement trigger (p.48), Integration (p.53), and remote sensing (p.70)
	View List	List display of measurement data (p.55)
	View Chart	Graph display of measurement data (p.55)
Sequence	Select edit	Setting the program (p.107)
	Initiate	Executing sequences (p.121)
	Export	Exporting programs (p.125)
	Import	Importing programs (p.126)
Status	Alarm Status	Confirm the alarm (p.67)
	SCPI Status	Confirm SCPI Errors (p.170)
Memory	*RST	Reset the settings (p.170)
	Memory Config	Set the confirmation operation at the time of recalling the preset memory (p.98) Panel settings at startup (p.76) Output state at power-on (p.77)
	Preset	Save / recall the preset memory (p.96)
	Setup	Save / recall the setup memory (p.99)
	Sanitize	Reset to factory default (p.167)
System	EXT Config	Set the external control (p.127)
	Communication	Display, set the communication function (p.149)
	VMCB	Setting Multichannel (p.154)
	Model Info	Display the information of models and system version (p.158)
	Key Lock Level	Set the key lock (p.159)
	Sound/Display	Set the buzzer sound (p.161) and screen brightness (p.162)
	Date Config	Set the year, month, day, and time (p.163)
	Update	Firmware update (p.166)

## Changing values

Press the item you want to change their set value. If there are multiple choices, a list of choices will be displayed. Press the item you want to set.

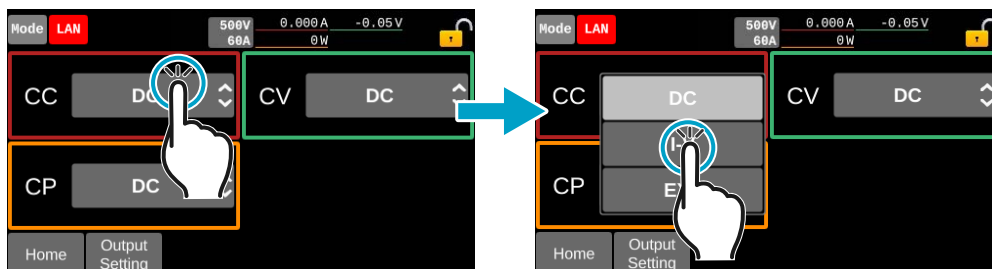

# Homepage

When the POWER switch is turned on, the model name and system version will be displayed, and then the homepage will appear. Swipe the display to the right or left, or press the ◀ or ▶ key on the front panel to switch the homepage to the right or left.

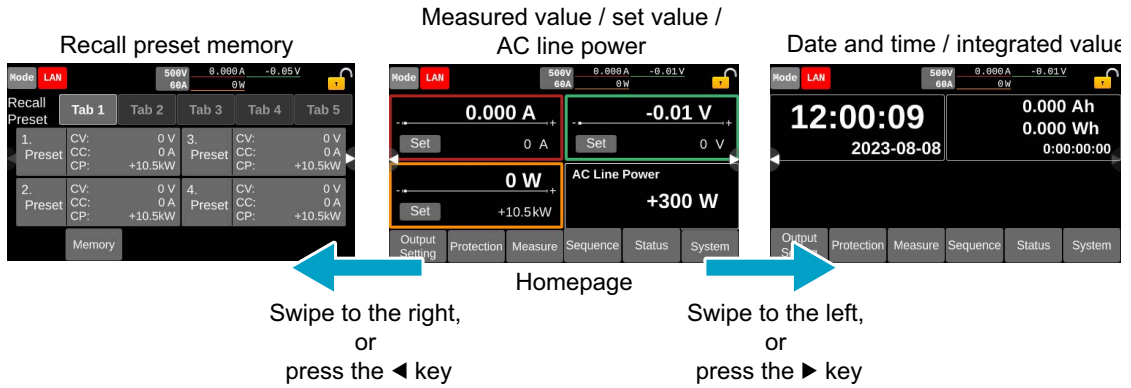

# Number and Character Input

Use the touch panel display, the ◀ and ▶ keys, and the rotary knob to enter numbers and characters.

When you press an item that requires numbers and characters for setting, the numeric or text input area will appear.

If numbers or characters are selected in an input area, they can be changed. If only a cursor is shown in an input area, you can enter characters or numbers at the cursor position.

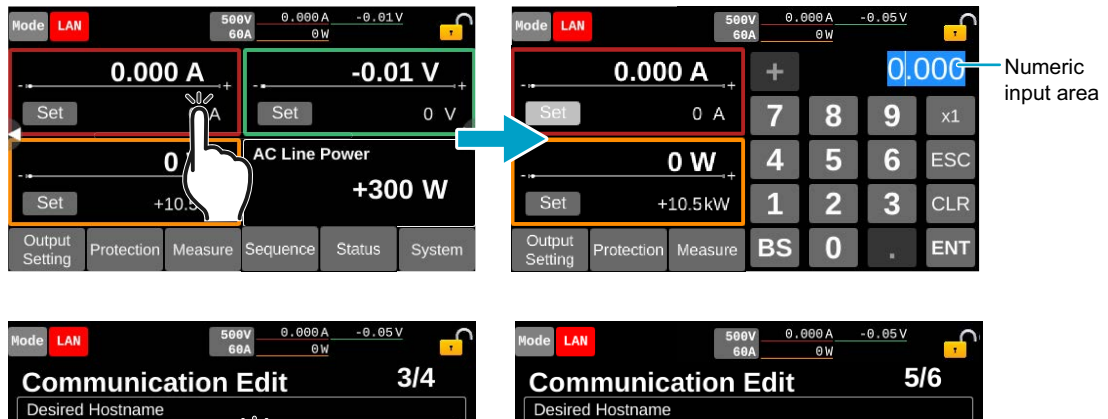

## Touch panel operation

### Numeric input

The diagram shows a numeric keypad with the following callouts:

- BS**: Delete one number or one decimal point at the left of the cursor.
- 0**: Fix the number.
- +**: The cursor will move to the location you pressed.
- 7, 8, 9**: Change the digits.
- ESC**: Cancel numeric input.
- CLR**: Set the number to 0.
- ENT**: Fix the number.

### Character input

The diagram shows a character input panel with the following callouts:

- ESC**: Cancel character input.
- CLR**: Delete all displayed characters.
- BS**: Delete one character at the left of the cursor.
- DEL**: Delete one character at the right of the cursor.
- INS**: Insert characters to the right of the cursor.
- 0**: Fix the character.
- OK**: Fix the character.

Switch the character types:

- a**: a - z      **A**: A - Z
- 0**: 1 - 9
- 0**: Symbols (@[\]^\_ ' {}~blank!" #\$\$\$&'()\*+,-. /;<=>?)

## Operations of the rotary knob and the ◀ / ▶ keys

Purpose	Controls	Description
Numeric input	Rotary knob	Select the number to enter. Turn clockwise to increase the value and counterclockwise to decrease. The value is confirmed immediately upon input.
Character input	Rotary knob	Select the characters to enter. Turn clockwise to select characters in ascending order. Turn counterclockwise to enter character in reverse order. To enter the next character, press the ◀ or ▶ key to move the cursor.
Cursor movement	◀ and ▶ keys	Change the digits or input position.

# Output ON/OFF

Use the OUTPUT key to turn on/off the output.

- 1 To turn on the output, press and hold the OUTPUT key (for about 0.2 seconds).  
To turn off the output, press the OUTPUT key.**

The output turns on and off each time that you press OUTPUT.

When the output is on, the OUTPUT LED lights.

When the output is off, the OUTPUT LED turns off.

When capacitive load is connected to DUT while bleeder ([p.44](#)) is enabled, the operation may continue until discharge completes after turning the output off, and OUTPUT LED may blink.

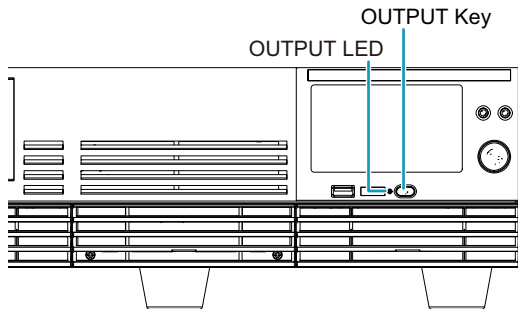

## ■ Controlling output on/off externally

Output on/off can be controlled using an external signal ([p.140](#)).

## ■ Synchronizing output ON/OFF with other PXT series

Output ON/OFF can be synchronized with the PXT series connected in synchronization ([p.86](#)).

## ■ Turning on the output on startup

You can turn on the output from the DC OUTPUT terminal on startup ([p.77](#)).

## Displaying the Measured Value and Setting the Output Value

On the homepage, the latest measured values are displayed. You can also change the set values of various outputs.

Output values can be changed during outputting, too.

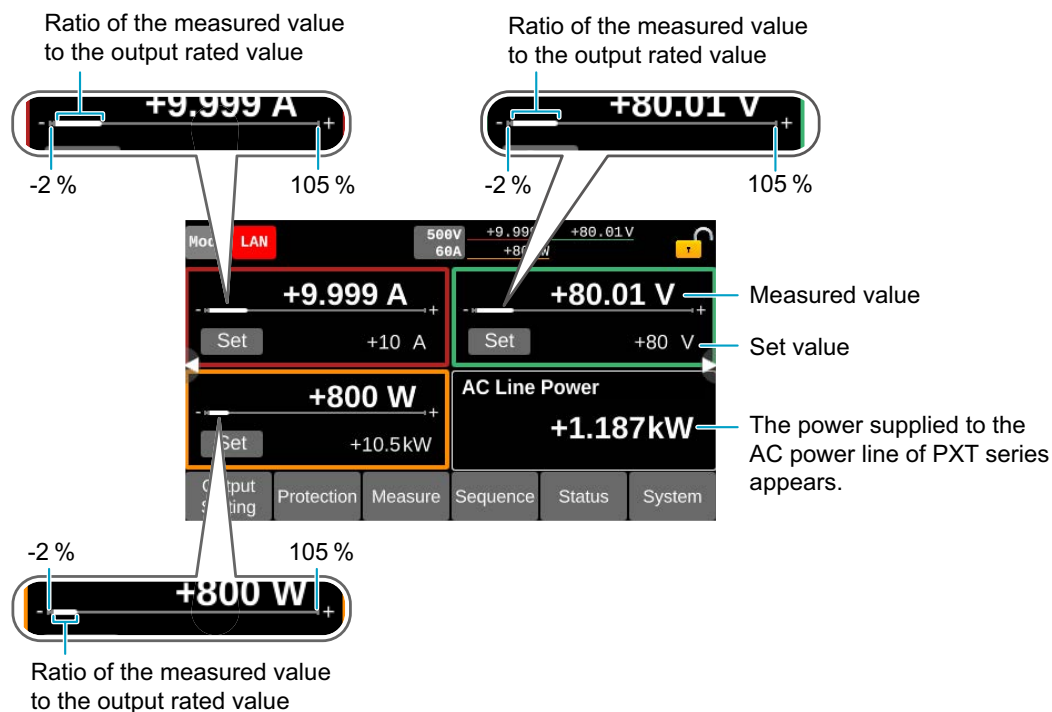

### NOTE

- The power display on the AC power line is a reference value and may fluctuate by approximately  $\pm 500$  W at the maximum.
- For no load (output terminal open), set the current setting to 0.5 % or more of the rated current while operating in CV mode.
- If the voltage setting is lowered during output, an undershoot of 2 % or less of the rated voltage may occur.

### 1 Press the output value to be set on the homepage.

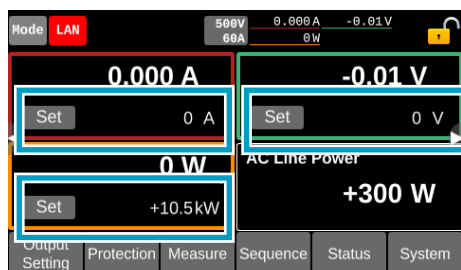

### 2 Use the display or the rotary knob to enter the output value. This completes the setting.

■ In the case that the value is displayed as EXT or I-V



Due to Setting the Output Mode (p. 46), the values cannot be changed from the display during external control (EXT) or I-V characteristic function operation (I-V).

■ When IR is displayed next to the voltage set value



CV is set to IR in “Setting the Output Mode” (p.46).

## Error display

When the current/voltage/power cannot be measured, an error will be displayed at the position of the measured value.

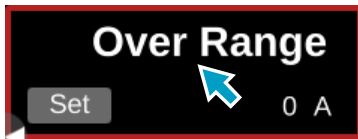

Error display	Description
Over Range	The value exceeded the measurement range.
Under Range	The value went below the measurement range.
Not Measurable	A HIGH alarm (p.59) is generated.

## Setting the Priority Operation Mode

In this product, the following operation modes are available: constant voltage (CV), constant current (CC), and constant power (CP).

You can select which operation mode is used for the output when it turns on. When the output reaches the set value, the operation mode changes automatically according to the DUT.

Select the CC mode when the connected DUT is such a device as a battery.

You cannot change the operation mode during output.

Item	Description
CV	Executes output in the Constant voltage mode when the output turns on. It maintains the set voltage even when the current changes.
CC	Executes output in the Constant current mode when the output turns on. It maintains the set current even when the voltage changes. When the output is turned ON with a voltage source such as battery connected externally, you can reduce the overshoot of current.
CP	Executes output in the Constant power mode when the output turns on. It maintains the set power even when the current or voltage changes. When the output is turned on with a large capacity load externally connected, both the output voltage and the output current may become large and activate an overpower protection (OPP) alarm. You may avoid alarms by using the CP mode.

### NOTE

- The voltage may fluctuate significantly when the DUT abruptly changes the current even if the CV mode is selected. If the voltage fluctuates, reduce the current slew rate of the DUT.
- The priority operation mode is enabled when the output voltage, output current, and output power are all 20 % or more of the rated values. In the case of 20 % or less, it will not be output in the intended operation mode and the start-up time will be delayed.

- 1 Press Output Setting > Priority / Bleeder on the homepage.**  
The same screen will appear when you press the Mode icon on the upper left part of the homepage.
- 2 Press the input field for Priority when output is ON to select the preferred operation mode.**

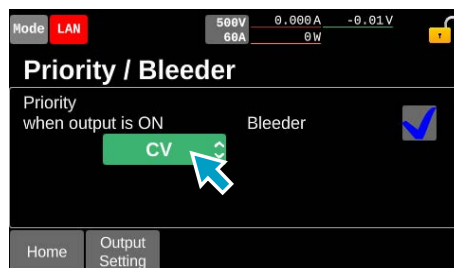

This completes the setting.

# Setting Bleeder

## WARNING

### Risk of electric shock.

- **When the settings of the bleeder is disabled, do not touch the DC OUTPUT terminal.**

When the bleeder is set to disabled, the voltage existed when the output was on remains in the output terminal even after you turn the output or POWER switch off.

When bleeder (discharge circuit) is enabled, the output voltage immediately drops by sink current while the output is off. However, when capacitive load is connected to DUT, the capacitive load is discharged while the output is off.

Change the settings depending on the DUT to be connected to. Settings cannot be configured during output.

Item	Description
Enable	Enables the bleeder. Sink current flows while the output is off.
Disable	Disables the bleeder. It can prevent excessive discharge while the output is off. However, slight sink current flows due to the internal resistance of PXT series. The reference values of the internal resistance are as follows: PXT20K-500: approx. 55 k $\Omega$ PXT20K-1000: approx. 220 k $\Omega$ PXT20K-1500: approx. 560 k $\Omega$

## NOTE

- When the bleeder is set disabled, voltage of hundreds of mV at maximum may occur at the DC OUTPUT terminal even under the following conditions.
  - When the DC OUTPUT terminal is released and the output is off
  - When the set voltage is 0 V
- In the parallel operation, use the same settings on all the connected PXT series.

**1** Press Output Setting > Priority / Bleeder on the homepage.

**2** Press the check box of the bleeder.

Each time you press the check box, the existence of checking changes. With a check mark, the bleeder turns to enable.

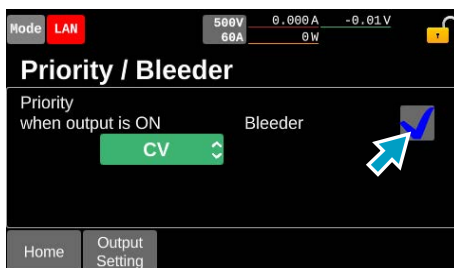

When the check box is cleared, a warning screen will be displayed. Check the content and press OK.

This completes the setting.

## Operation duration after output OFF operation

---

When capacitive load is connected to DUT while bleeder is enabled, the operation may continue until discharge completes after turning the output off, and OUTPUT LED may blink.

Discharging continues for 30 seconds at maximum depending on the DUT capacity. For more information on the discharge capacity for 30 seconds, refer to “Discharge Capacity after Output OFF Operation” ([p. 195](#)).

If you press the OUTPUT key while OUTPUT LED is blinking, discharging stops and OUTPUT LED goes out. However, voltage remains in the DC OUTPUT terminal.

---

### NOTE

If you press the OUTPUT key while OUTPUT LED is blinking, discharging stops and OUTPUT LED goes out. However, voltage remains in the DC OUTPUT terminal.

---

## Setting the Output Mode

Set how to control the output for each operation mode. You cannot set it while outputting from the DC OUTPUT terminal.

Item	Description
CC	It maintains the set current even when the voltage changes.
DC	This is the normal output mode. Controls the current at the set current value.
I-V	Controlled by arbitrary I-V characteristics. (p.78)
EXT	The current setting is controlled by external voltage (p.134). The external voltage input to EXT CONT is treated as an absolute value and applied to the current setting values.
CV	It maintains the set voltage even when the current changes.
DC	This is the normal output mode. Controls the voltage at the set voltage value.
I-V	Controlled by arbitrary I-V characteristics. (p.78)
IR	Enable the internal resistance function. Operate in CV mode to make the voltage conform with the changes in the current and the set resistance (p.83).
EXT	The voltage is controlled by external voltage. (p.127)
CP	It maintains the set power even when the voltage and/or current change.
DC	This is the normal output mode. Controls the power at the set power value.
EXT	The power setting is controlled by external voltage (p.134). The external voltage input to EXT CONT is treated as an absolute value and applied to the power setting values.

### NOTE

- You cannot set CC and CP to EXT simultaneously.
- When setting I-V to CC, you cannot set I-V or IR to CV simultaneously.
- When setting I-V or IR to CV, you cannot set I-V to CC simultaneously.

- 1 Press **Output Setting > Output Mode** on the homepage.
- 2 Press the input field of each operation mode to select the **Output Mode**.

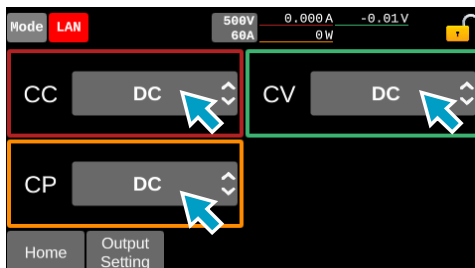

This completes the setting.

# Measurement Recording

You can record the measured values (voltage, current, power, elapsed time, integrated current, and integrated power). To record them, set the recording conditions and then operate the touch panel display to start recording.

## Recording measured values

You can record the following measured values:

- The average values (of voltage, current, and power) measured during the recording period set in Average (p.48) of Acquire Trigger after the start of recording.
- The integrated values (of elapsed time, integrated current, and integrated power) at a point in time when the period set in Average (p.48) of Acquire Trigger has elapsed since the start of the recording.

**1** Press **Measure > View List or View Chart** on the homepage.

**2** Press **Acquire/Integral**.

The following figure shows an example of the View List screen.

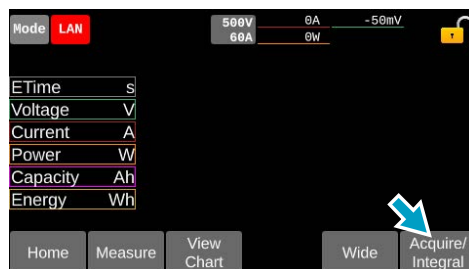

Execute measurement screen is displayed.

On the execute measurement screen, the menu can be switched between menus related measurement and menus related to integration.

The menus related to integration is displayed when the conditions for starting/stopping integration and resetting the integration value are set to Manual.

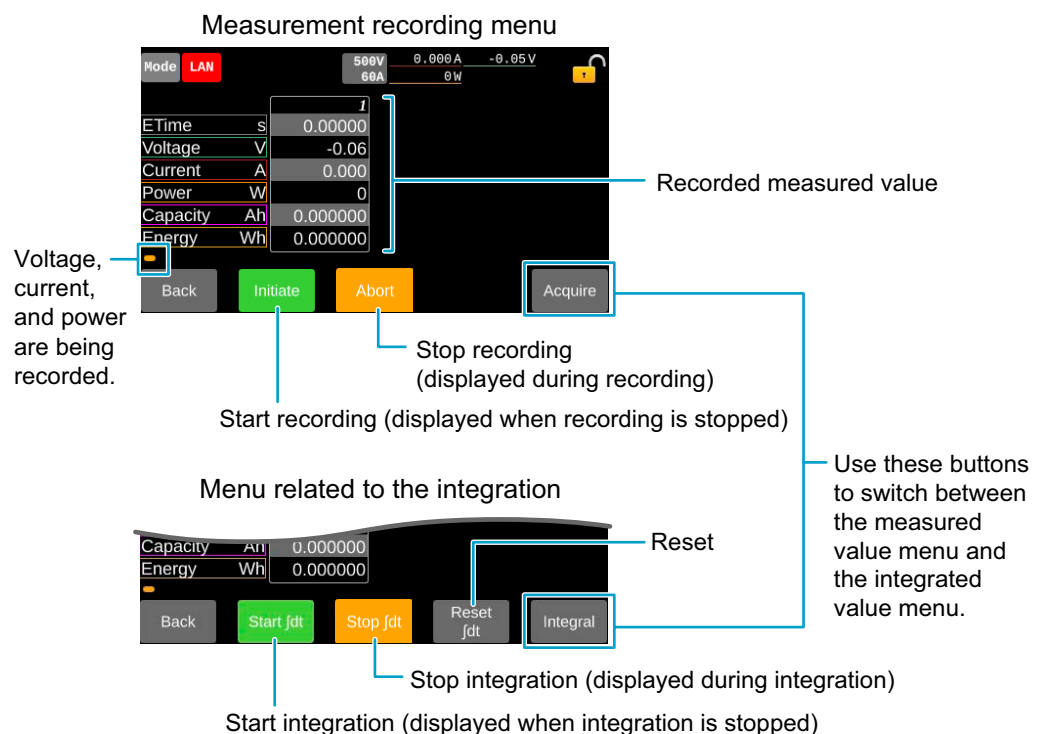

## Changing the settings of measurement

Press Measure > Measure Config on the homepage to change the measurement settings.

To display settings not fully displayed on the screen, swipe the measurement setting area to the left or right, or press the ◀▶ keys to scroll the screen.

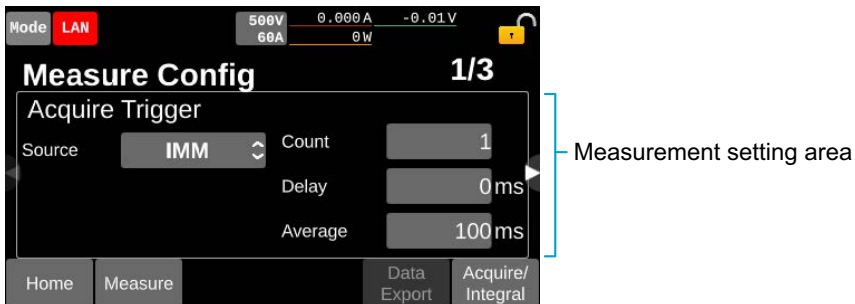

You can set the following conditions.

Item	Description
Acquire Trigger	Source Set the condition to start recording measured values (trigger source). (p.49)
	Average Sets the number of times measurement values are to be recorded. (p.49)
	Delay Set the delay time until the measurement is started after the trigger is applied. (p.50)
	Average Sets the recording time period per measurement. (p.50)
Acquire Interval	Timer When Enable is checked, the recording interval time is set. (p.50)
	Enable Set whether to measure at intervals when the measured values are recorded two or more times. (p.50)

## Measurement trigger settings

### ■ Trigger wait settings

Set the condition to start measurement (trigger source).

Inputting the set trigger source is input applies the trigger. Press the input field for Source to select the value with the display.

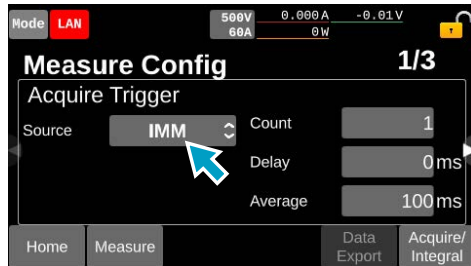

Item	Description
IMM	A trigger is applied immediately.
BUS	A trigger is applied when the *TRG command is received by remote control.
EXT	The trigger is applied at the time of inputting a signal to the terminal where the general-purpose digital input of the EXT CONT connector (p. 140) is set to ACQUIRE TRIG.
MSYN	Trigger is applied when Msync is pressed during synchronization (p. 87) or when receiving a sync signal of measurement by remote control.
Output OFF	The trigger is applied when the output is turned off.

### ■ Setting the number of times of recording

Sets the number of times measurement values are to be recorded.

Press the input field for Count to select the value with the display or the rotary knob.

Busy is displayed during measurement and key operations will be disabled.

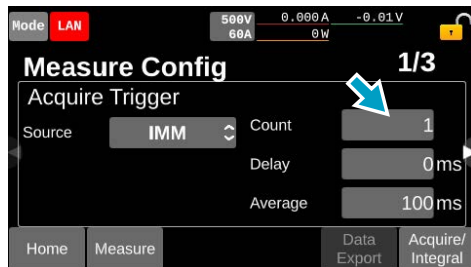

Setting range: 1 to 65536

### ■ Setting the delay time

Set the delay time until the measurement is started after the trigger is applied.  
 Press the input field for Delay to select the value with the display or the rotary knob.

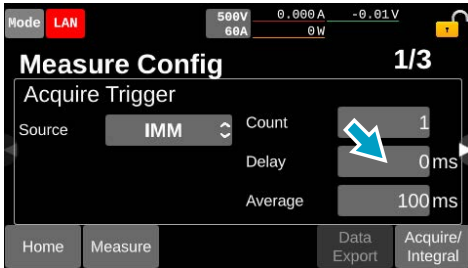

Setting range: 0 ms to 100000 ms

### ■ Setting the recording time

Sets the recording time period per measurement.  
 For voltage, current, and power, the average value is recorded within the Average time after the measurement is started. For elapsed time, integrated current, and integrated power, the integrated value is recorded at a point in time when the Average time has elapsed after the measurement is started.  
 Press the input field for Average to select the value with the display or the rotary knob.

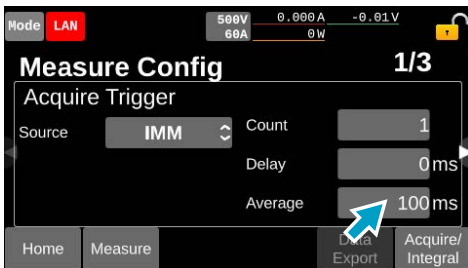

Setting range: 0.1 ms to 1000 ms

### Setting the recording interval

Set the recording interval time when measured values are recorded two or more times. Press the input field for Timer to select the value with the display or the rotary knob. Press the input field for Enable and check it to enable the Timer.

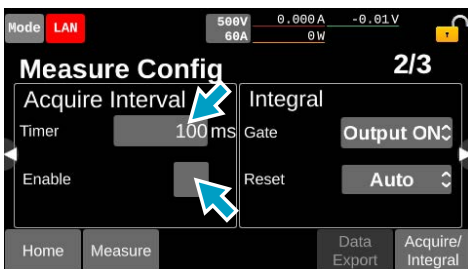

Setting range: 0.1 ms to 3600000 ms

### Example of measurement operation

Source: IMM  
 Count: 3  
 Enable: No check

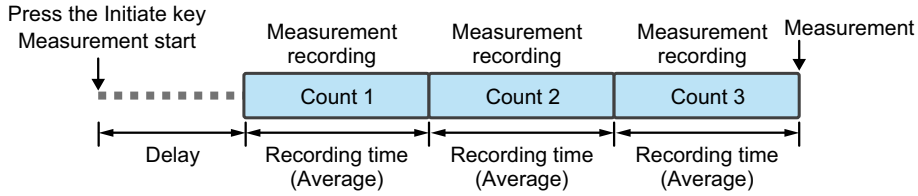

Source: IMM  
 Count: 3  
 Enable: With check

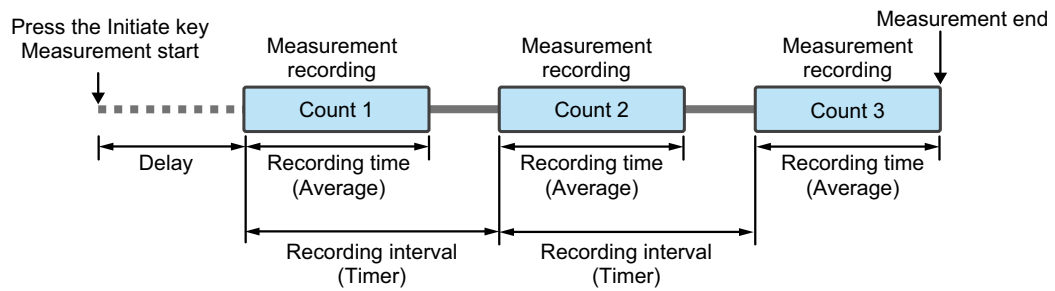

Source: BUS, EXT, MSYN or Output OFF  
 Count: 2  
 Enable: With check

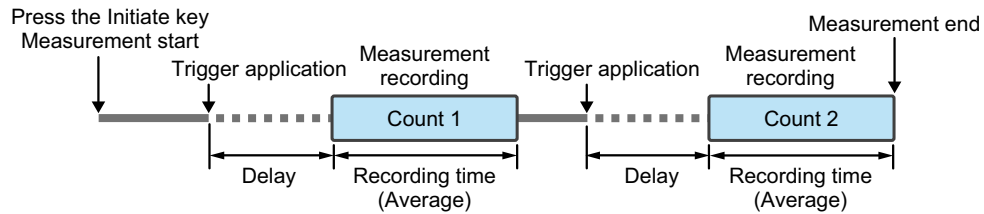

Source: BUS, EXT, MSYN, or Output OFF  
 Count: 3  
 Enable: With check

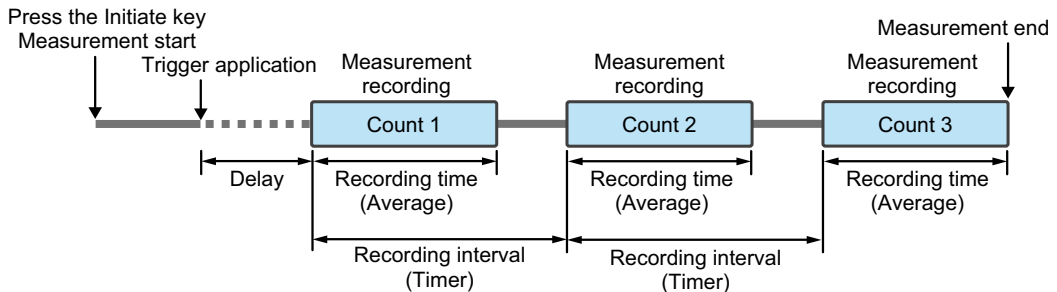

### Measurement recording flowchart

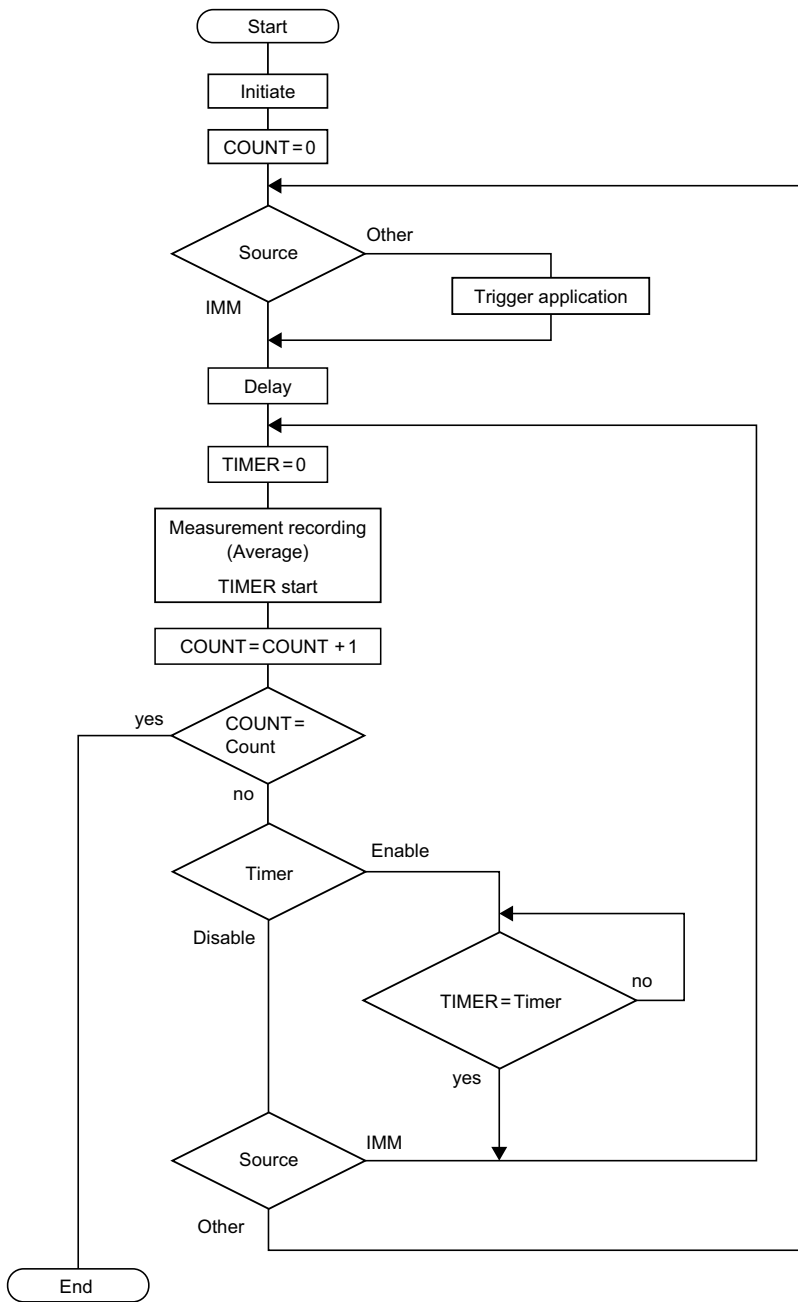

## Changing the integration settings

Pressing Measure > Measure Config on the homepage and swipe to the left or press the ► key on the front panel will enable to change the integration settings.

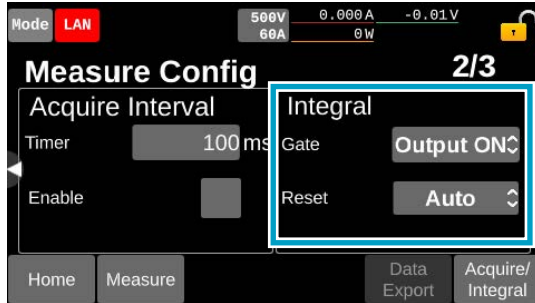

You can set the following conditions.

Item	Description
Integral Gate	Set the conditions for starting and stopping the integration of elapsed time, current, and power. (p.53)
Reset	Sets the condition to reset the recorded integrated value. (p.54)

### Conditions for starting/stopping integration

Set the conditions for starting and stopping the integration of elapsed time, current, and power.

Press the input field for Gate to select the value with the display.

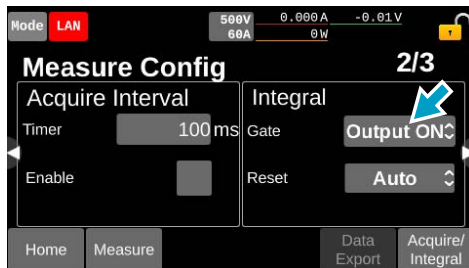

Item	Description
Manual	Press Start [dt] to start integration, and press Stop [dt] to stop integration.
Output ON	Integration is started/stopped interlocking with output ON/OFF.
EXT	Integration starts/stops when a signal (p.140) is input to the EXT CONT connector.
PROG RUN	Integration is started/stopped interlocking with sequence execution.

### Conditions for resetting the integrated values

Conditions for resetting the recorded integrated values. When you turn the POWER switch on again after turning it off, the integrated value is reset.

Press the input field for Reset to select the value with the display.

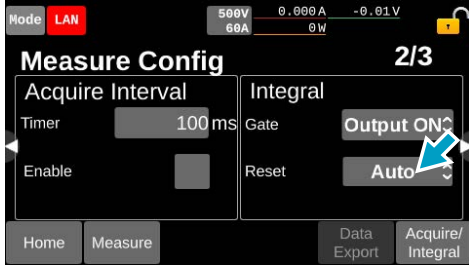

Item	Description
Manual	Press Reset $\int$ dt to reset.
Auto	The value is automatically reset before starting the integration.
EXT	The value is reset when a signal (p.140) is input to the EXT CONT connector.

### Example of Integration operation

Gate: Output ON

Reset: Auto

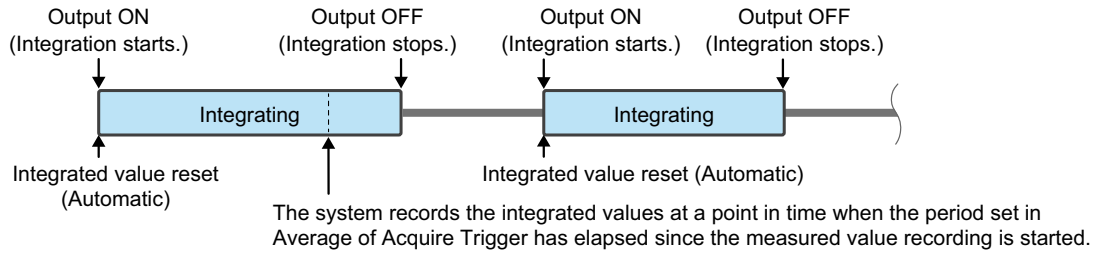

Gate: Manual

Reset: Manual

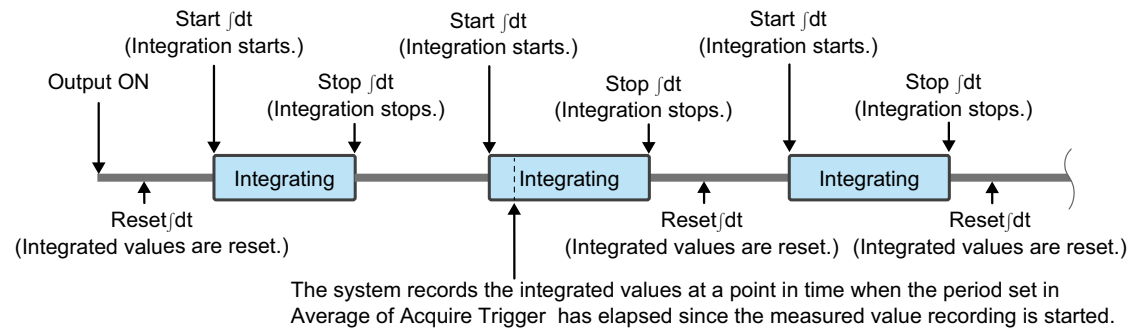

## Displaying the measured value recorded

Measured values can be displayed in the list and graph forms.

### NOTE

The measured values are redrawn each time they are displayed. Since it takes time to draw when there are 2000 measurement points or more (approximately 14 minutes maximum as a guide), it may appear that it becomes busy status or the measurement is ongoing even after the measurement is complete.

### Displaying in the table form

Pressing Measure > View List on the homepage enables to display recorded measured values according to the number of times recorded.

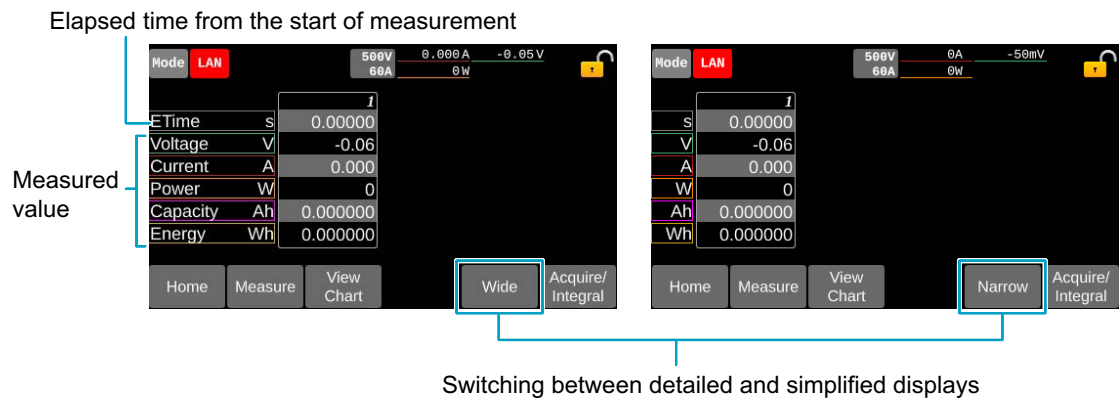

Pressing Wide or Narrow enables to switch between detailed and simplified displays.

Pressing View Chart switches to the display in graph form.

### Displaying in the graph form

Pressing Measure > View Chart on the homepage enables to display recorded measured values in the graph form.

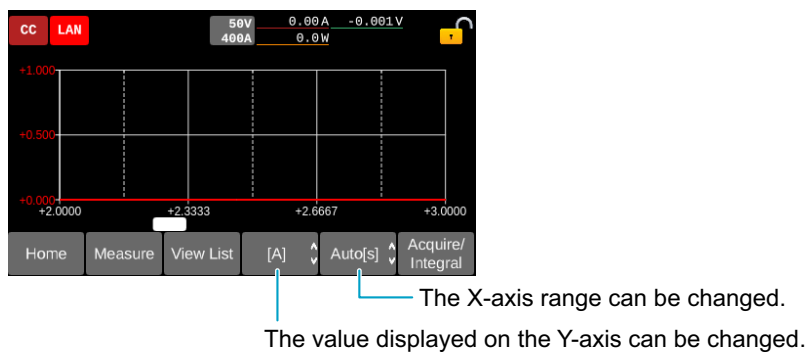

The value to be displayed on the Y-axis can be selected from current, voltage, or current and voltage. Displays the elapsed time since the start of measurement on the X-axis. The range of the X-axis can be changed.

Item	Selectable values
Values to be displayed on the Y-axis	[V],[A]/[V]/[A]
X-axis range	Auto[s]/Auto[min]/Auto[h]/30.0[min]/60.0[min]/10.0[h]/50.0[h]/100.0[h]

## Switching between list and graph format display

Pressing View Chart or View List enables to switch between list and graph format displays.

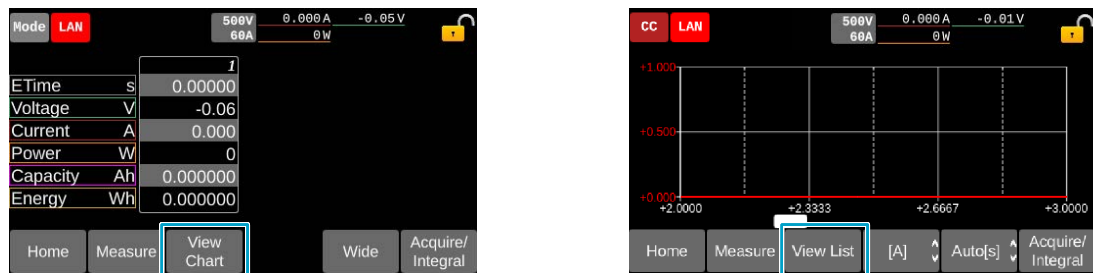

Switching between list and graph format

## Exporting measured values to a USB memory device

Saves the measured value recorded in the PXT series to a USB memory device in CSV format. To open the CSV files, use an application that is compatible with the CSV format in order to prevent the index part from being turned into a character string.

- 1** Insert a USB memory device into the USB connector on the front panel.
- 2** Press Measure > Measure Config on the homepage.
- 3** Press Data Export.

A "MEAS" folder is created on the USB memory device and the CSV file will be saved. When there are no recorded measured values, Data Export will be grayed out.

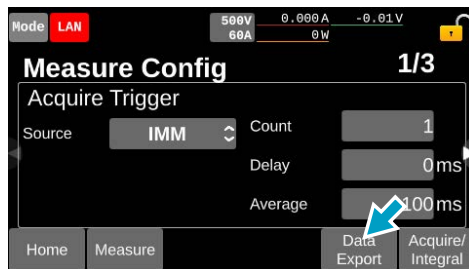

## Displaying the most recent integrated values

Swiping to the left on the homepage or pressing the ► key enables to display the latest integration value.

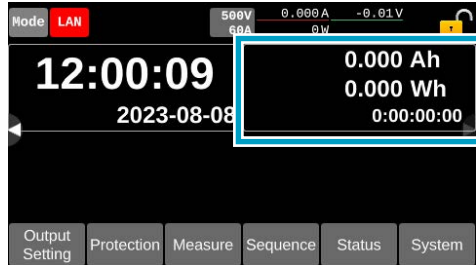

# Protection Functions

When a protection function is activated, an alarm is generated. Here, alarm types, how to set the protection function, and the operation when an alarm is generated are explained.

## Alarm Types

There are two levels in alarm (LOW / HIGH) depending on the level of urgency.

### LOW alarm

When LOW alarm goes off, output of the DC OUTPUT terminal gets turned off. While a sequence is running, the sequence is paused. Check the settings that is being a cause of the alarm. Remove the cause of the alarm, then clear the alarm (p.69). It is not necessary to turn off power of the PXT series. When the alarm is released, the paused sequence is resumed.

#### LOW alarms that occur on the master unit during standalone operation or parallel operation

Name	Display indication	Description
Overvoltage protection	OVP	A voltage at the OVP set value (p.61) or higher was applied to the DC OUTPUT terminal.
Undervoltage protection	UVP	The voltage at the DC OUTPUT terminal dropped to the UVP set value (p.62) or lower.
Overcurrent protection	OCP	A current at the OCP set value (p.63) or higher flowed to the DC OUTPUT terminal.
Overpower protection	OPP	Electric power of the OPP set value (p.64) or higher was generated at the DC OUTPUT terminal.
Communication error protection	WDOG	SCPI communication was not performed to or over the time set under the communication error protection (p.66).
External input alarm detection	EXT LOW	A signal was entered to the terminal where L ALARM IN is set by the general-purpose digital input of the EXT CONT connector. Clear the signal entered to the EXT CONT connector.

#### LOW alarms that occur on the master unit during parallel operation

Name	Display indication	Description
Slave unit overvoltage protection	SLV OVP	A voltage higher than the rated voltage was applied to the slave unit. Make sure that the wiring of the load cables are appropriate.
Slave unit overcurrent protection	SLV OCP	A current in excess of the rated current flowed to the slave unit. Make sure that the wiring of the load cables are appropriate.
Slave unit overpower protection	SLV OPP	Power in excess of the rated power was generated in the slave unit. Make sure that the wiring of the load cables are appropriate.

## HIGH alarm

### WARNING

#### Risk of electric shock.

- If you turn off the POWER switch due to a HIGH alarm, do not touch the DC OUTPUT terminal. A residual charge may exist in the DC OUTPUT terminal. For more information on the required time for the discharge, refer to “Guide for Required Time for Residual Voltage Discharge” (p. 193).

When HIGH alarm is generated, output of the DC OUTPUT terminal gets turned off, and the power supply on the primary side will stop. Turn off power of PXT series to remove the cause of the problem, then turn on power again. If the OHP alarm goes off, leave it for about 10 minutes with power on.

### HIGH alarms that occur on the master unit during standalone operation or parallel operation

Name	Display indication	Description
Reverse-connection detection protection	REVE	A negative voltage was applied to the DC OUTPUT terminal. If this happens, immediately shut off the DUT output.
Overheat protection	OHP	The temperature of the internal devices exceeds the standard. Make sure that the front-panel air inlet and rear-panel air outlet are not blocked, and leave it for about 10 minutes with power on. Then, turn off power and turn on power again.
Grid overvoltage protection	LOVP	A voltage at or higher the LINE OVP set value was applied to the AC INPUT terminal.
Grid undervoltage protection	LUVP	Input voltage rating 200 Vac model: Input voltage at the AC INPUT terminal is less than 175 V. Input voltage rating 400 Vac model: Input voltage at the AC INPUT terminal is less than 333 V.
Grid abnormal frequency protection	FREQ	A frequency other than the input frequency (42 Hz to 68 Hz) was entered to the INPUT terminal.
External input alarm detection	EXT HIGH	A signal is entered to H ALARM IN (Pin No. 21) of the EXT CONT connector. Cancel the signal input, disable the digital I/O (p. 139), turn the power off, and then back on.
Incorrect sensing connection detection	SENS	The voltage difference between DC OUTPUT terminal and the sensing terminal is 10 % or more of the rated output voltage. Make sure that there is no reverse connection or disconnection, and that the load cables are appropriate.
Hardware error	ERRH	A problem occurred in PXT series hardware. If the alarm does not clear, even after turning off the power supply of the PXT series unit and then turning on it, contact your Kikusui agent or distributor.
Software error	ERRS	A problem occurred in PXT series software. If the alarm does not clear, even after turning off the power supply of the PXT series unit and then turning on it, contact your Kikusui agent or distributor.

## HIGH alarms that occur on the master unit or slave units during parallel operation

Name	Display indication	Applicable function	Description
Parallel operation communication error	PARA COM	Master unit Slave unit	An error occurred in communication with a PXT series unit connected in parallel operation. Turn off the POWER switch of PXT series, check the parallel operation signal cable connection, and then turn on the POWER switch again.
Not applicable device connected	SLV INC	Slave unit	A model with a different voltage rating than the master unit is connected in parallel.
Too many parallel connections	TOO MANY	Master unit	Ten or more slave units were connected.
Slave unit hardware error	SLV ERRH	Master unit	A problem occurred in the slave unit hardware. If the alarm does not clear, even after turning off the power supply of the PXT series unit and then turning on it, contact your Kikusui agent or distributor.
Slave unit software error	SLV ERRS	Master unit	A problem occurred in the slave unit software. If the alarm does not clear, even after turning off the power supply of the PXT series unit and then turning on it, contact your Kikusui agent or distributor.
Slave unit overheat protection	SLV OHP	Master unit	The temperature of the internal device of the slave unit exceeded the preset value. Make sure that the front-panel air inlet and rear-panel air outlet are not blocked, and leave it for about 10 minutes with power on. Then, turn off power and turn on power again.
Slave unit system over-voltage protection	SLV LOVP	Master unit	A voltage higher than the LINE OVP setting was applied to the AC INPUT terminal of the slave unit.
Slave unit system frequency abnormal	SLV FREQ	Master unit	A frequency other than the input frequency (42 Hz to 68 Hz) was input to the AC INPUT terminal of the slave unit.
Slave unit system under-voltage protection	SLV LUVP	Master unit	When the slave unit is input voltage rating 200 Vac model: The input voltage at the AC INPUT terminal has become less than 175 V. When the slave unit is input voltage rating 400 Vac model: The input voltage at the AC INPUT terminal has become less than 333 V.
Slave unit abnormal	SLV OTHR	Slave unit	An alarm of another unit was detected.

# Setting the Protection Functions

## Setting overvoltage protection (OVP)

When a voltage at the set value or higher is applied to the DC OUTPUT terminal, an alarm occurs, and the output of the DC OUTPUT terminal gets turned off.

- 1 Press Protection on the homepage.
- 2 Press the input field for OVP.

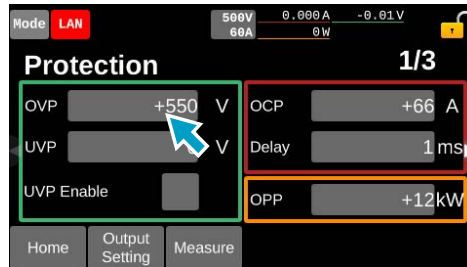

Setting range (PXT20K-500): 50 V to 550 V

Setting range (PXT20K-1000): 100 V to 1100 V

Setting range (PXT20K-1500): 150 V to 1650 V

- 3 Use the display or the rotary knob to enter the voltage value.  
This completes the setting.

## Setting undervoltage protection (UVP)

When a voltage of the DC OUTPUT terminal drops to the set value or lower, an alarm occurs, and the output of the DC OUTPUT terminal gets turned off. You can also disable UVP.

### NOTE

When using UVP, turn on the output and enable UVP after the voltage reaches the value. Since the protection function is activated right after the output is on, the alarm is triggered when the voltage right after turning output on is at UVP value or less.

**1** Press Protection on the homepage.

**2** Set the voltage of UVP.

Press the input field for UVP to enter the voltage value on the display or by the rotary knob.

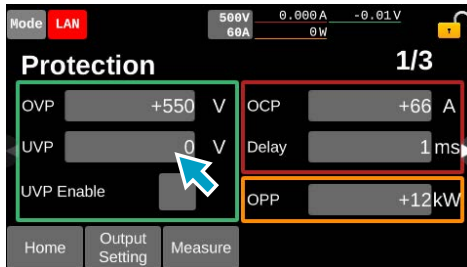

Setting range (PXT20K-500): 0 V to 500 V

Setting range (PXT20K-1000): 0 V to 1000 V

Setting range (PXT20K-1500): 0 V to 1500 V

**3** Enable or disable UVP.

Press the check box of UVP Enable. Each time you press the check box, the existence of checking changes. With a check mark, UVP is enabled, without a check, UVP is disabled.

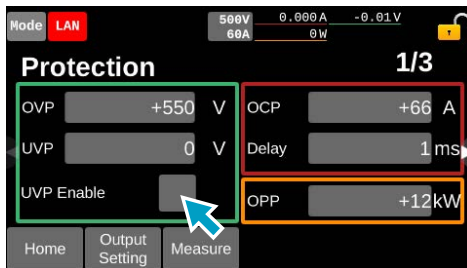

This completes the setting.

## Setting overcurrent protection (OCP)

When an electric current at the set value or higher flows to the DC OUTPUT terminal, an alarm occurs, and the output of the DC OUTPUT terminal gets turned off. The delay time from the detection of an electric current at the set value or higher to the activation of the OCP can also be set.

**1 Press Protection on the homepage.**

**2 Set the current in OCP.**

Press the input field for OCP, and enter the current value on the display or by the rotary knob.

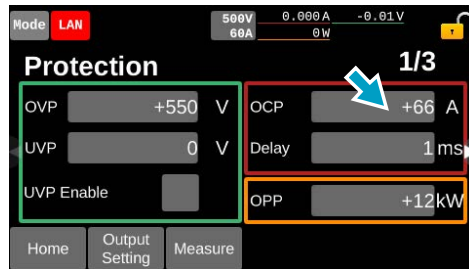

Setting range (PXT20K-500): 12 A to 132 A

Setting range (PXT20K-1000): 6 A to 66 A

Setting range (PXT20K-1500): 3 A to 33 A

**3 Set the delay time to the activation of the OCP.**

Press the input field for Delay to enter the delay time on the display or by the rotary knob.

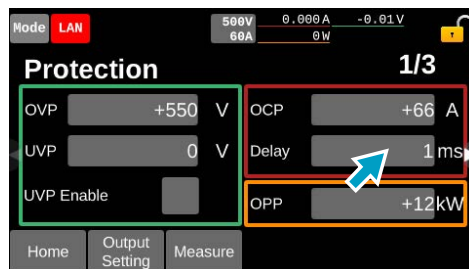

Setting range: 1 ms to 2000 ms

This completes the setting.

## Setting overpower protection (OPP)

When an electric power at the set value or higher is generated in the DC OUTPUT terminal, an alarm occurs, and the output of the DC OUTPUT terminal gets turned off.

**1** Press Protection on the homepage.

**2** Press the input field for OPP.

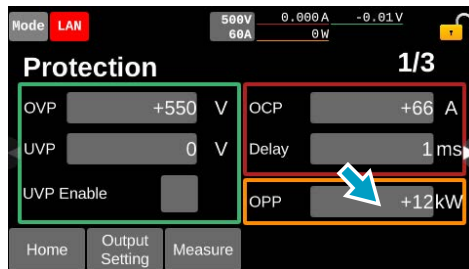

Setting resolution: 2 W

Setting range: 2 kW to 24 kW

**3** Use the display or the rotary knob to enter the power value.

This completes the setting.

## Setting grid overvoltage protection (LOVP)

When a voltage at the set value or higher is applied to the AC INPUT terminal, an alarm occurs, and the output of the DC OUTPUT terminal gets turned off.

- 1 Press Protection on the homepage.
- 2 Swipe to the left, or press the ► key.
- 3 Press the input field for Line OVP.

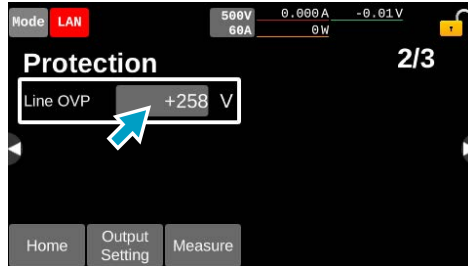

Input voltage rating 200 Vac model: 200 V to 258 V  
Input voltage rating 400 Vac model: 380 V to 516 V

- 4 Use the display or the rotary knob to enter the voltage value.  
This completes the setting.

## Setting communication error protection (WDOG)

When SCPI communication does not take place for a time at the WDOG set value or longer, an alarm occurs, and the output of the DC OUTPUT terminal gets turned off. You can also disable WDOG.

- 1** Press Protection on the homepage.
- 2** Swipe to the left, or press the ► key, till WDog is displayed.
- 3** Enter the set value for WDog.

Press the input field for WDog to enter the time on the display or by the rotary knob.



Setting range: 1 s to 3600 s

- 4** Enable / disable WDog.
- Press the check box of WDog Enable. Each time you press the check box, the existence of checking changes. With a check mark, UVP is enabled, without a check, UVP is disabled.



This completes the setting.

# Remedying Alarm Generation

## When an alarm occurs

### Common actions

When the protection function is activated and an alarm occurs, the output of the DC OUTPUT terminal will be turned off. A message corresponding to the alarm level will be indicated on the display. Press OK to display the alarm screen. If alarm-related settings are made for the general-purpose digital output of the external control (p.142), the signal of the EXT CONT connector corresponding to the settings will be turned on.

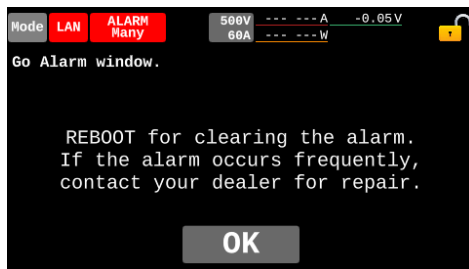

### When the overheat protection (OHP) is activated

A message stating that the product must be cooled for 10 minutes with the power supply left on is displayed before the alarm is cleared. Press "Next" to see a message corresponding to the alarm level.

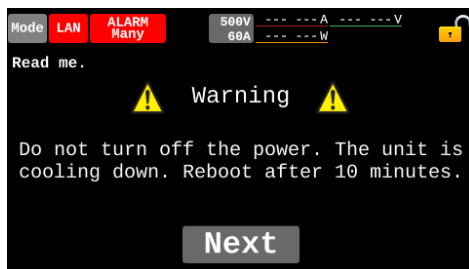

### When the grid undervoltage protection (LUV) is activated

A screen similar to the one when you turned off power will appear, and "Next" will be displayed 15 seconds after. Press "Next" to see a message corresponding to the alarm level.

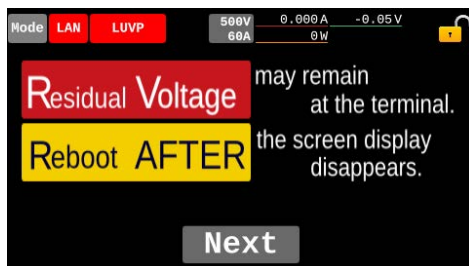

## Checking alarm screen

On the alarm screen, the alarm name and message will be displayed. When the alarm names are not fully displayed on one screen, swipe the list of alarm names or press the ◀/▶ keys to scroll the screen.

The alarm screen can also be displayed by pressing Status > Alarm Status on the homepage.

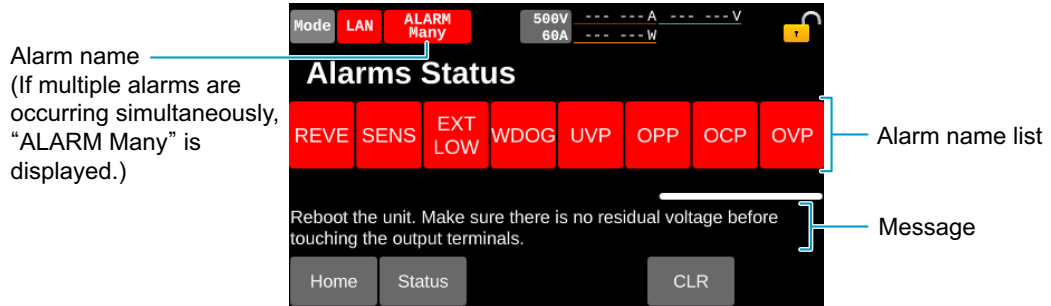

For the details of alarm names and descriptions, refer to "Alarm Types" (p.58).

## Clearing an alarm

The recovery method varies depending on the level of the alarm occurring. The recovery method will be displayed on the alarm screen as a message. For details, refer to "Alarm Types" (p.58).

### Clearing LOW alarm

- 1 Remove the cause of the alarm.
- 2 Press CLR.  
The alarm is cleared.

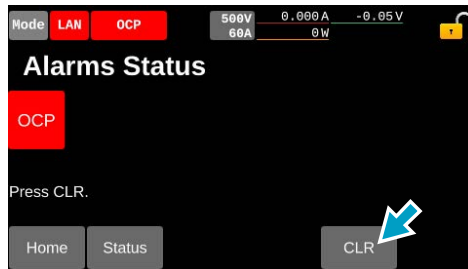

#### NOTE

- If the cause of the alarm remains, the alarm will occur again.
- You can also clear the LOW alarm with an external control signal (p.140).

### Clearing HIGH alarm

- 1 Turn off the **POWER** switch, and remove the cause of the alarm.  
In the case of OHP alarm, make sure that the front-panel air inlet and rear-panel air outlet are not blocked, and leave it for about 10 minutes with power on. Then, turn off the POWER switch.
- 2 Turn on the **POWER** switch again.  
The alarm is cleared.

#### NOTE

If you want to turn the POWER switch back on, wait at least 10 seconds after the fan stops. Repeatedly turning the POWER switch on and off at short intervals will shorten the service life of the POWER switch and the internal input fuse.

# Advanced Functions

## Remote Sensing

You can change a voltage measurement point from a DC OUTPUT terminal to an arbitrary sensing point. By setting the sensing point to the DUT end, up to 10 % of the rated voltage can be compensated in a reciprocating motion. Remote sensing stabilizes the load current by reducing the effects of voltage drop, etc. caused by the load cable resistance.

To use remote sensing, connect PXT series to the load with sensing cables and enable remote sensing.

### Connecting the sensing cables

#### **⚠ WARNING**

Risk of electric shock.

- Do not connect cables to the SENSING terminals while the POWER switch is turned on.
- For SENSING cables, use cables whose rated voltage is higher than the isolation voltage of PXT series.

Recommended wiring: UL3239; Rated voltage 3 kV

- Make sure not to have the conductor of the cable touch the chassis when connecting.
- Before turn the POWER switch on, make sure that the Sensing terminal cover is attached.

#### **⚠ CAUTION**

PXT series and DUT may be damaged.

- Securely connect wires of the designated wire diameter to the SENSING terminals.

Make sure that wiring is not disconnected during remote sensing.

Connect the sensing cables to the SENSING terminals (+S, -S) of PXT series and the DUT end. Use AWG22 - AWG16 cables when connecting to the sensing terminals. When performing parallel operation, connect the sensing cable only to the master unit.

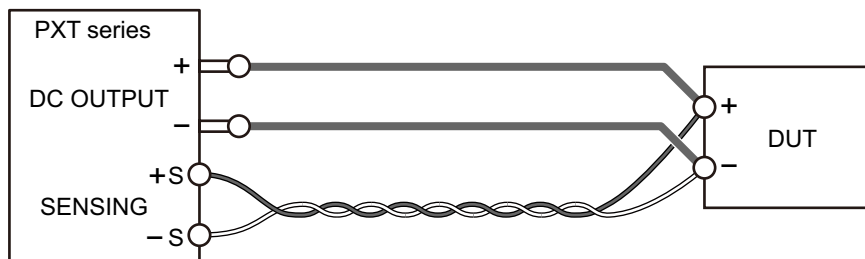

**1** Turn the **POWER** switch off (○) and remove the sensing terminal cover from the sensing terminal.

**2** Insert the sensing cables to the included sensing terminal cover.

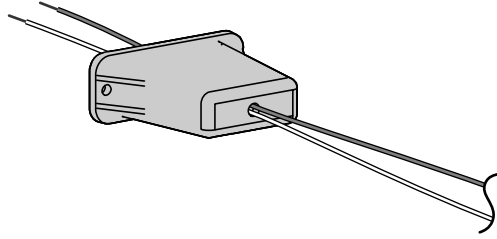

**3** Connect the sensing cables to the included sensing connectors. Strip approximately 8 mm of coating from the end of the sensing cable.

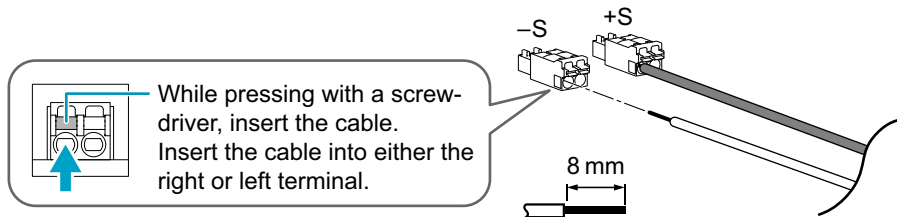

**4** Connect the sensing connectors to the sensing terminal. The following figure shows an example of PXT20K-1500.

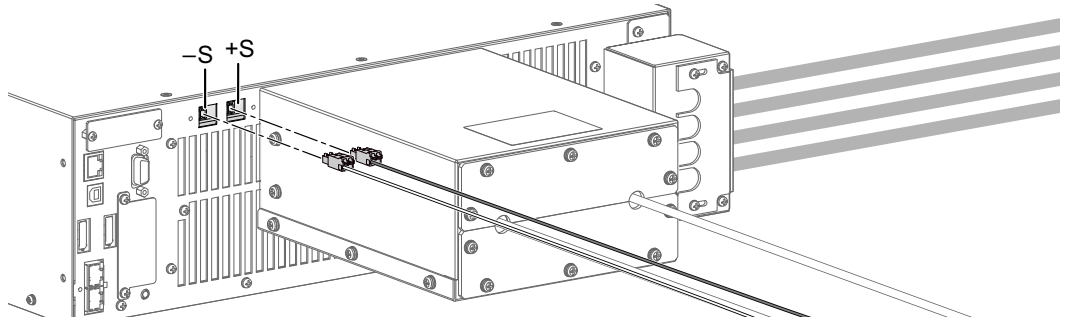

**5** Attach the sensing terminal cover. The following figure shows an example of PXT20K-1500.

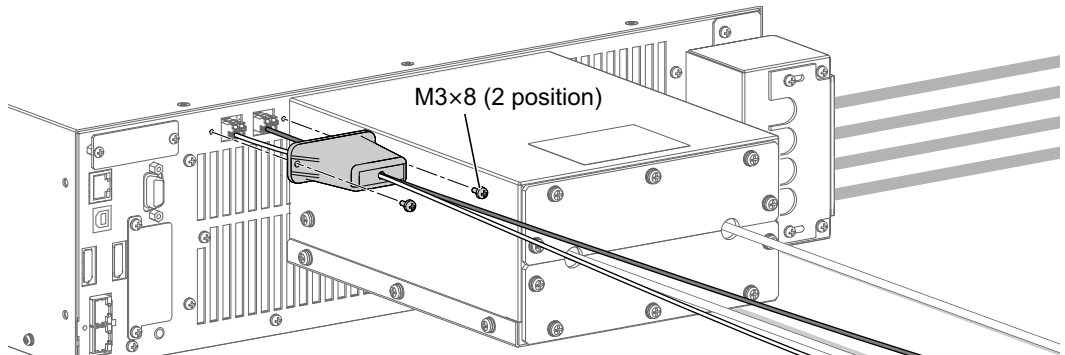



**6** Connect the sensing cables to the DUT. Twist the sensing cables, and connect the SENSING terminals with the DUT terminals by matching their polarities. This completes the connections.

## Enabling or disabling remote sensing

After connecting the sensing cables to the SENSING terminals, enable remote sensing. You cannot set it while outputting from the DC OUTPUT terminal.

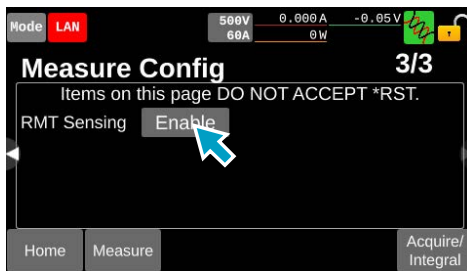
- 1 Press Measure > Measure Config on the homepage.**
- 2 Swipe to the left, or press the ► key, till RMT Sensing is displayed.**
- 3 Press the input field for RMT Sensing.**  
The value switches between Enabled and Disabled each time that you press the key.



When remote sensing is enabled, the sensing icon (  ) appears on the upper right part of the display.

This completes the setting.

# Response

Select the response in the CV mode / CC mode from "SLOW" or "FAST."  
You cannot set it while outputting from the DC OUTPUT terminal.

## NOTE

When the response speed is set to FAST, the operation may become unstable if the load cable is long or has a large loop. In those cases, set the response to SLOW.

- 1 Press **Output Setting > Response / Slew Rate** on the homepage.
- 2 Press the input field for **CV or CC** below **Response**.  
Each time you press the field, it switches between SLOW and FAST.

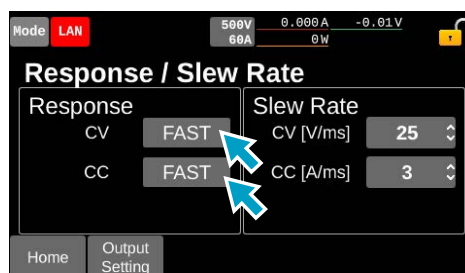

This completes the setting.

# Slew Rate

## Setting slew rate

Set the amount of change per unit time when changing the current or voltage in the CV or CC mode. The value is common to rising and falling slopes. You cannot set it while outputting from the DC OUTPUT terminal.

The slew rate functions in the following cases.

- When the current or voltage value is changed by changing the set value.
- When the current or voltage value is changed by an external control.
- When the current or voltage value is changed by turning the output on.
- When the output is turned off.

Model	Operation mode	Slew rate
PXT20K-500	CV [V/ms]	0.125/1.25/12.5/25
	CC [A/ms]	0.03/0.3/3/6
PXT20K-1000	CV [V/ms]	0.250/2.50/25.0/50
	CC [A/ms]	0.015/0.15/1.5/3
PXT20K-1500	CV [V/ms]	0.375/3.75/37.5/75
	CC [A/ms]	0.0075/0.075/0.75/1.5

### NOTE

In the CV mode, the slew rate set at the time of falling may not be achieved due to the load current. The fall time at the time with no load is 750 ms.

- 1 Press **Output Setting > Response / Slew Rate** on the homepage.
- 2 Press the input field for **CV [V/ms]** or **CC [A/ms]** below **Slew Rate**.

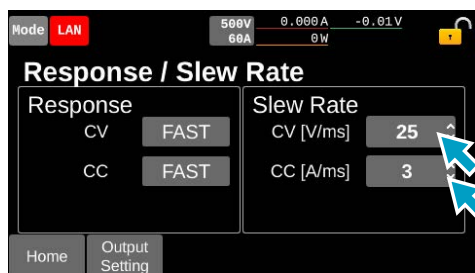

- 3 **Select the slew rate value.**  
This completes the setting.

# Setting Output Delay

You can set the delay from when the OUTPUT key is pressed to when the output actually turns on or off. A blinking yellow mark is displayed on the top left of the screen during the output delay time.



Item	Setting	Description
Output ON Delay	0 s to 99.9 s	Sets the delay time to the time the output is turned on.
Output OFF Delay	0 s to 99.9 s	Sets the delay time to the time the output is turned off.

## NOTE

If the setting is changed during a delay operation, the set time is immediately reflected.

Example) When the Output ON Delay is set to 5 seconds, if the setting is changed to 10 seconds at 3 seconds after the OUTPUT key is pressed, the delay is extended to 7 seconds from that point.

- 1 Press Output Setting > Output Delay on the homepage.
- 2 Press Output ON Delay or Output OFF Delay.

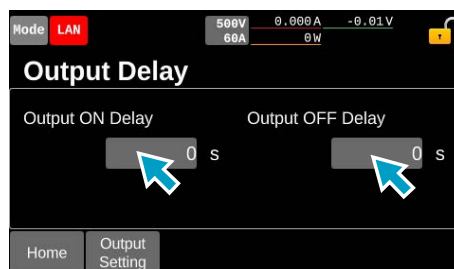

This completes the setting.

# Settings at Startup

Select the setting condition when the POWER switch is turned on.

The setting of Power ON Output (p.77) is reflected to the output state from the DC OUTPUT terminal.

Item	Description
RST	Start with the reset settings (p.190).
Recall	Starts in the state of loading an arbitrary setup memory.
Resume	Starts at the settings applied when the POWER switch was turned off last time.

- 1 Swipe to the right, or press the ◀ key on the homepage.
- 2 Press Memory > Memory Config.
- 3 Press the input field for Power ON Setting.

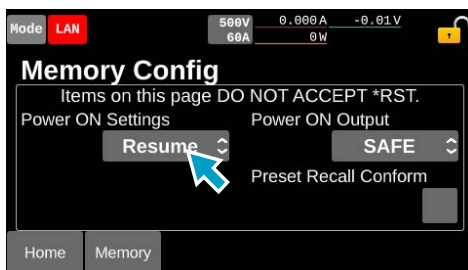

- 4 Select and press the item.
- 5 In the case of selecting Recall, press the input field for Recall Setup File and Input the number of the setup memory with the display or the rotary knob.

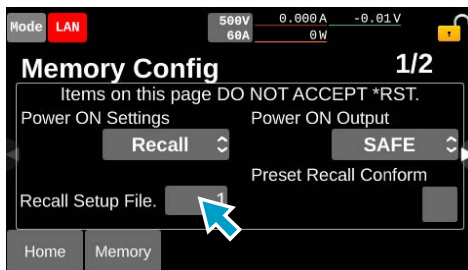

This completes the setting.

# Output State at Startup

Set the output state from the DC OUTPUT terminal when the POWER switch is turned on.

Item	Description
SAFE	Starts with the output turned off.
AUTO	Operation varies depending on the settings at startup (p.76). Starts with the output turned off in the case of RST. If Resume is set, starts at the settings applied when the POWER switch was turned off last time. Starts with the output state at the time of recalling the setup memory in the case of Recall.
FORCE	Starts with the output turned on.

**1** Swipe to the right, or press the ◀ key on the homepage.

**2** Press Memory > Memory Config.

**3** Press the input field for Power ON Output.

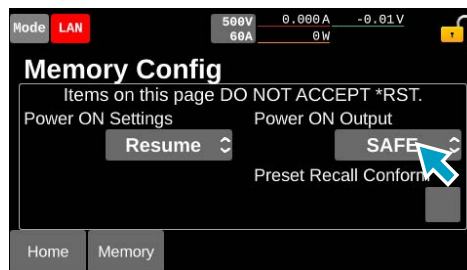

**4** Select and press the item.  
This completes the setting.

## I-V Characteristic Function

Arbitrary I-V characteristics can be set according to each CC and CV operation mode by registering multiple I-V characteristic points (pairs of voltage and current values). Three to 100 points can be registered, and the space between two points is linearly interpolated. They can be used for solar cell simulation, etc. Examples of PXT20K-1500 and CC mode settings are shown.

Points	Voltage [V]	Current [A]
1	0	20.000
2	300	20.000
3	360	18.000
4	400	16.000
5	500	10.000
6	600	0.000
7	1575	0.000

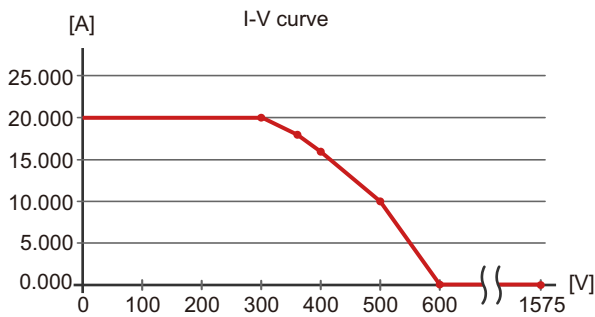

### NOTE

- Delay of approx. 50 ms at maximum will occur before turning output on.
- When the output vibrates, reduce the slew rate ([p.74](#)).

## Setting I-V characteristics

Set the numbers of points of the I-V characteristics and set the voltage and current values for each score.

- 1 Press Output Setting on the homepage.
- 2 Swipe to the left, or press the ► key, till “I-V List” is displayed and press I-V List.

The I-V characteristic edit screen is displayed.

To see I-V characteristics not fully displayed on the screen, swipe to the left and press the ► key or the rotary knob to scroll the display.

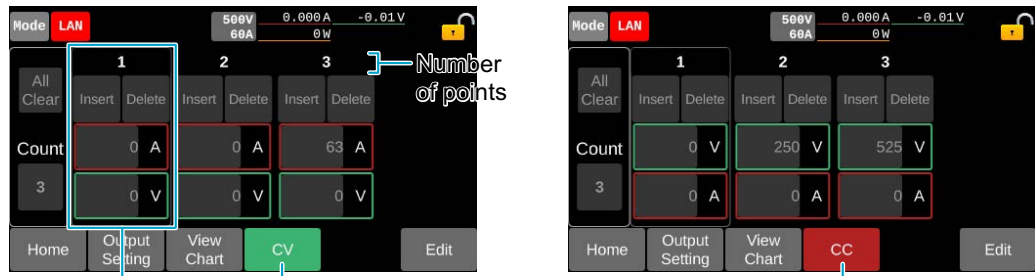

Settings of voltage and current per point.

Operation mode to be displayed can be switched.

- 3 Press Edit

The I-V characteristic editing screen is displayed. The following figure shows an example of the CV mode.

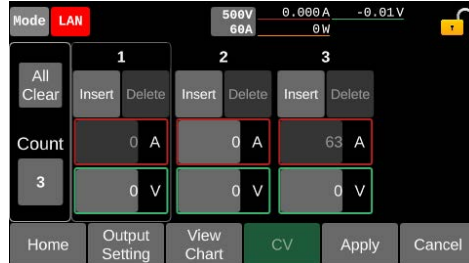

Then, set the number of points of the I-V characteristics and input the value. Points can also be inserted or deleted.

## Setting the number of points of the I-V characteristics

Changing the value of Count on the I-V characteristic editing screen changes the number of points of the I-V characteristics.

To increase the number of points, copy the selected points and add them at the end. To reduce the number of points, delete the points behind, including the points being selected. The first and last points cannot be deleted.

Selection is made by pressing the number of points.

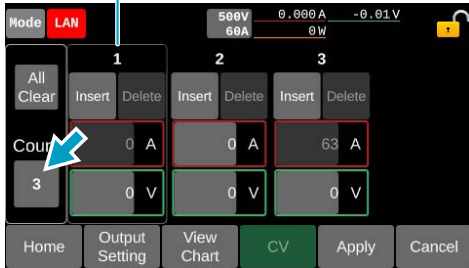

## Inserting and deleting points

Press Insert to insert points. Copy points and insert one point at the end.

Press Delete to delete points. The first and last points cannot be deleted.

To return the I-V characteristics to its initial setting, press All Clear.

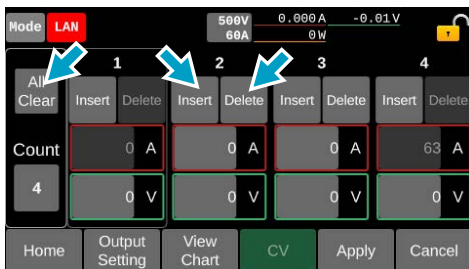

## Inputting values

Press the input field for each value to input the value with the display or the rotary knob.

In CV mode, the current at the first point is fixed at the minimum value and the current at the last point is fixed at the maximum value. In CV mode, the voltage at the first point is fixed at the minimum value and the voltage at the last point is fixed at the maximum value.

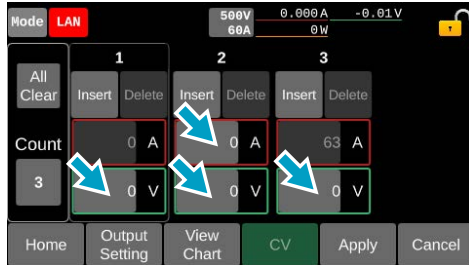

After input, the current in the case of CV mode and the voltage in the case of CC mode are sorted in ascending order from left to right at the following timings:

- When switching between list and graph displays
- When displaying a screen other than the I-V characteristics edit screen
- When pressing Apply or Cancel

## Switching between list and graph displays

To switch between list and graph displays, press View Chart or View List on the I-V Characteristic edit screen.

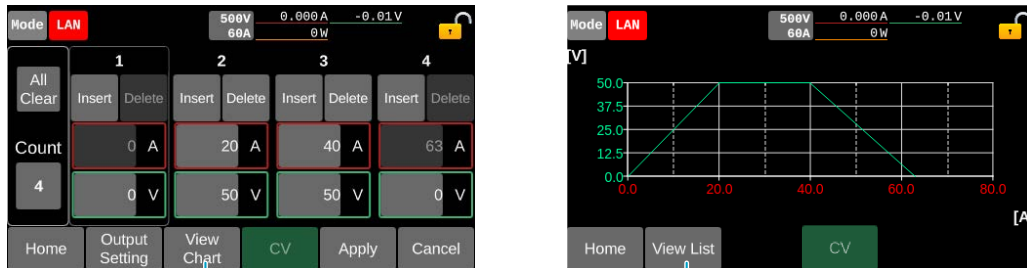

Graph and list displays can be switched.

## Application and cancellation of I-V characteristics

Press Apply to apply I-V characteristics. As a verification screen is displayed, press OK. I-V characteristic is saved.

To enable the I-V characteristic function, set the output mode of the CV/CC mode to I-V ([p.82](#)).

To clear editing of the I-V characteristics, press Cancel. As a verification screen is displayed, press OK.

## Enabling the I-V characteristic function

Selecting I-V in the output mode of the CV/CC mode enables the I-V characteristic function.

### NOTE

- When setting I-V or IR to CV, you cannot set I-V to CC simultaneously.
- When setting I-V to CC, you cannot set I-V to CV simultaneously.

- 1 Press **Output Setting > Output Mode** on the homepage.
- 2 Press the input field for **CV/CC** to set the output mode to **I-V**.

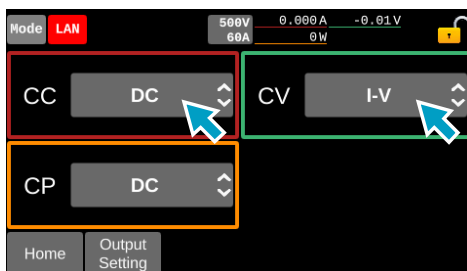

This completes the setting.

# Internal Resistance Function

By setting the internal resistance value, you can decrease the output voltage according to the output current. You can easily simulate rechargeable batteries, solar batteries, fuel cells, and other power supplies that have internal resistance.

## Setting resistance

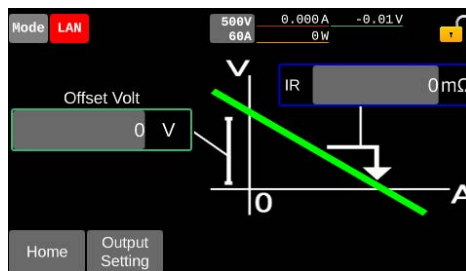

- 1** Press Output Setting on the homepage.
- 2** Swipe to the left, or press the ► key, till “IR” is displayed and press IR.
- 3** Press the input field for Offset Volt to enter the voltage value on the display or by the rotary knob.  
The voltage of Offset Volt is the same as the voltage value on the homepage.
- 4** Press the input field for IR to enter the resistance value on the display or by the rotary knob.

Model	Setting range	Setting accuracy
PXT20K-500	0 mΩ to 5250 mΩ	1 mΩ
PXT20K-1000	0 mΩ to 21000 mΩ	2 mΩ
PXT20K-1500	0 mΩ to 63000 mΩ	5 mΩ

This completes the setting.

To enable the internal resistance function, set the output mode of the CV mode to IR ([p.84](#)).

### NOTE

If the output oscillates when using the internal resistance function, slow down Response ([p.73](#)) and Slew Rate ([p.74](#)).

## Enabling the internal resistance function

To enable the internal resistance function, set the output mode of the CV mode to IR.

### NOTE

When setting I-V to CC, you cannot set IR to CV simultaneously.

**1** Press **Output Setting > Output Mode** on the homepage.

**2** Press the input field for **CV**.

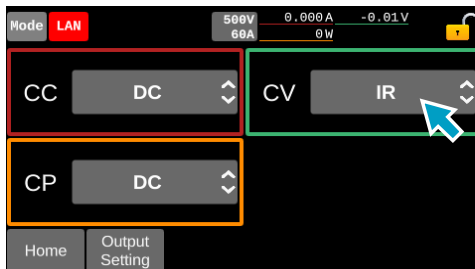

**3** Press **IR**.  
This completes the setting.

# Synchronized Operation

Connecting PXT series with each other via synchronized operation signal cable enables synchronized operation of output ON/OFF, measurement, and sequence from any PXT series being connected.

Any of the PXT series models can be connected together. Synchronized operation is possible even during parallel operation.

## Connection for synchronized operation

Use the included synchronized operation signal cable kit to connect the PXT series for synchronized operation.

- 1** Turn off all the PXT series products that you will connect.
- 2** Connect all PXT series with the included synchronized operation signal cables. Connect the OUT connector and IN connector of the EXT SYNC with a synchronized operation signal cables.

Connection example

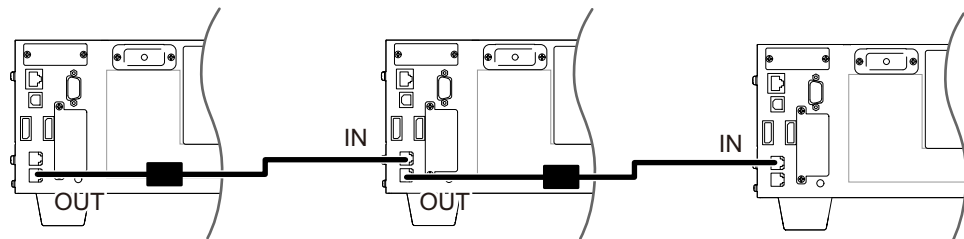

- 3** When you complete the connection, attach the included EXT SYNC port cover.

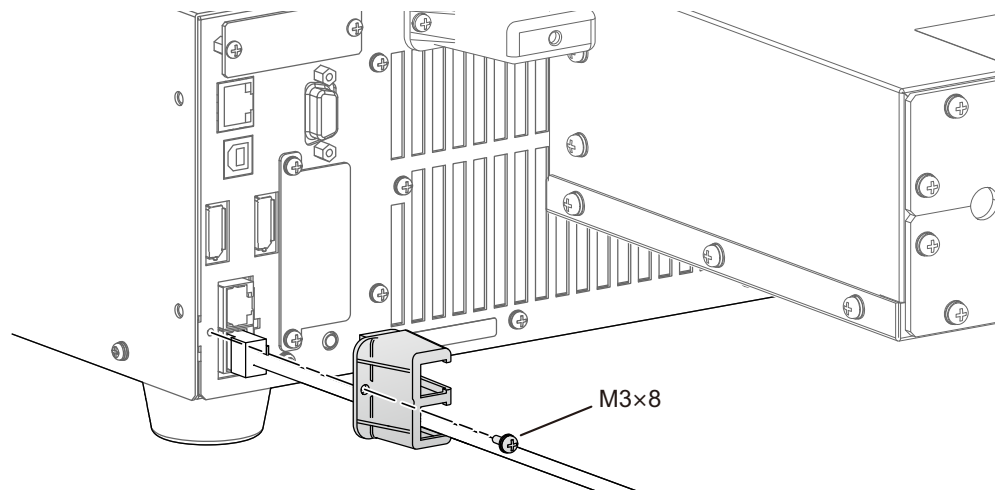

This completes the connections.

When synchronized operation becomes possible, the Sync icon (Sync) appears in the upper right corner of the display.

## Synchronization of output ON/OFF

Synchronizes output ON/OFF with multiple PXT series connected in synchronization.

### NOTE

Even during synchronized output on/off operation, when the OUTPUT key on the front panel is pressed, output is turned ON/OFF only for the PXT series on which the OUTPUT key is pressed.

- 1 Press Output Setting on the homepage.
- 2 Swipe to the left, or press the ► key, till Synchronize is displayed and press Synchronize.
- 3 Press the input field for Msync Output Enable and check the box.

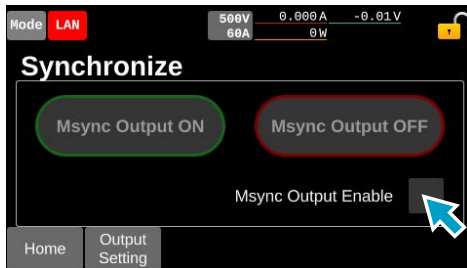

- 4 Perform Step 1 to Step 3 on all PXT series to be synchronized.
- 5 Press Msync Output ON or Msync Output OFF on the homepage of any PXT series connected in synchronization.  
Output is turned ON/OFF simultaneously in all PXT series to be synchronized.

## Synchronization of the measurement start

The start of measurement is synchronized among multiple PXT series products connected in synchronization.

- 1 Press **Measure > Measure Config** on the homepage.  
The Measure Config screen is displayed.
- 2 Press the input field for **Source** to select **MSYN** with the display.

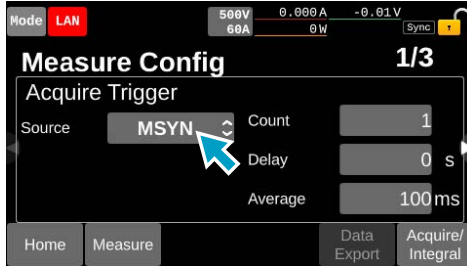

- 3 Press **Acquire/Integral > Initiate**.
- 4 Perform Step 1 to Step 3 on all PXT series to be synchronized.
- 5 Press **Acquire > Msync** on any of the Measure Config screens of the PXT series that are connected in synchronization.

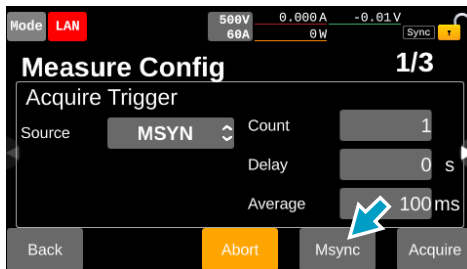

Measurement starts simultaneously on all synchronized PXT series products.

## Synchronization of the program start

The start of program is synchronized among multiple PXT series products connected in synchronization.

- 1 Press Sequence > Select edit on the homepage.**  
The program list screen is displayed.
- 2 Hold down the program to be synchronized, or press the program and press the selected program again.**  
The program setup screen is displayed.
- 3 Press the input field for Wait Trig to select MSYN with the display.**



- 4 Press Initiate > Run.**  
Sequence is paused and enters a trigger wait state.
- 5 Perform Step 1 to Step 4 on all PXT series to be synchronized.**
- 6 Press Msync on any PXT series connected in synchronization.**



Trigger wait is released for all PXT series to be synchronized, and sequence starts simultaneously.

## Synchronization of the step start

When Wait Trig (p. 116) is set to MSYN in the program step, sequence pauses (waits for trigger) before starting steps. The release of trigger wait is synchronized among multiple PXT series products connected in synchronization.

- 1 Set Wait Trig to MSYN in the program step settings for all PXT series to be synchronized. (p. 116)
- 2 Starting sequence in all PXT series to be synchronized.
- 3 Wait for sequence to pause in all PXT series to be synchronized.  
Sequence is paused before starting the step for which Wait Trig is set to Msync, and enters trigger wait state. Msync is displayed in the menu area.
- 4 Press Msync on any of PXT series connected in synchronization.

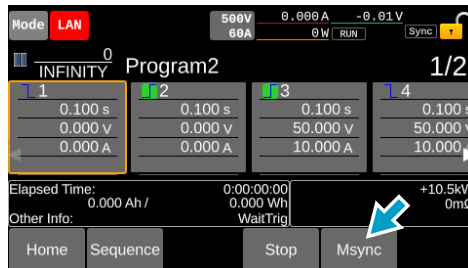

Trigger wait is released for all PXT series to be synchronized, and sequence resumes simultaneously.

## Returning from synchronized operation to standalone operation

The synchronized operation setting is cleared when you remove the synchronized operation signal cables.

# Parallel Operation

PXT series units can be connected in parallel to increase the current and power capacities.

For parallel connection, use the optional parallel operation signal cable kit (p.198).

You can control up to nine slave units from a master unit. Parallel operation is also possible among models with different input voltage ratings. The master unit and the slave units are automatically configured according to the connection status. The master unit displays the total output current, total output power, and total power of the AC power lines for all the units that are connected in parallel.

## NOTE

- The system version of all PXT series units to be operated in parallel must be the same.
- During parallel operation, the product may not meet the specifications that it has during independent operation. The setting accuracy and measurement accuracy can be improved by performing calibration in a parallel state. To have your product calibrated, contact your Kikusui agent or distributor.
- The setting resolution during parallel operation varies depending on the number of units in parallel operation.
- Series operation is not possible.

### ■ Maximum current and maximum power during parallel operation (when the models are all the same)

Number of slaves	Maximum current / Maximum power		
	PXT20K-500	PXT20K-1000	PXT20K-1500
1	240 A/40 kW	120 A/40 kW	60 A/40 kW
2	360 A/60 kW	180 A/60 kW	90 A/60 kW
3	480 A/80 kW	240 A/80 kW	120 A/80 kW
4	600 A/100 kW	300 A/100 kW	150 A/100 kW
5	720 A/120 kW	360 A/120 kW	180 A/120 kW
6	840 A/140 kW	420 A/140 kW	210 A/140 kW
7	960 A/160 kW	480 A/160 kW	240 A/160 kW
8	1080 A/180 kW	540 A/180 kW	270 A/180 kW
9	1200 A/200 kW	600 A/200 kW	300 A/200 kW

## Making connections for parallel operation

Connect the PXT series units to be operated in parallel to the DUT, and connect each unit using parallel operation signal cables.

This section explains an example of performing parallel operation using three PXT20K-500 units.

### ⚠ WARNING

#### Risk of fire.

- Use load cables having strong flame-resistant insulation with sufficient margin for the current.

#### Risk of electric shock.

- Turn the POWER switch off before you touch the DC OUTPUT terminal.
- Attach the DC OUTPUT terminal cover after wiring the load cables.

### ⚠ CAUTION

PXT series and DUT may be damaged.

- Do not leave one end of the parallel operation signal cable connected to the PARALLEL connector when the other end is not connected.

### NOTE

If there is a PXT series unit not used in parallel operation, disconnect the parallel operation signal cable.

### Connection example

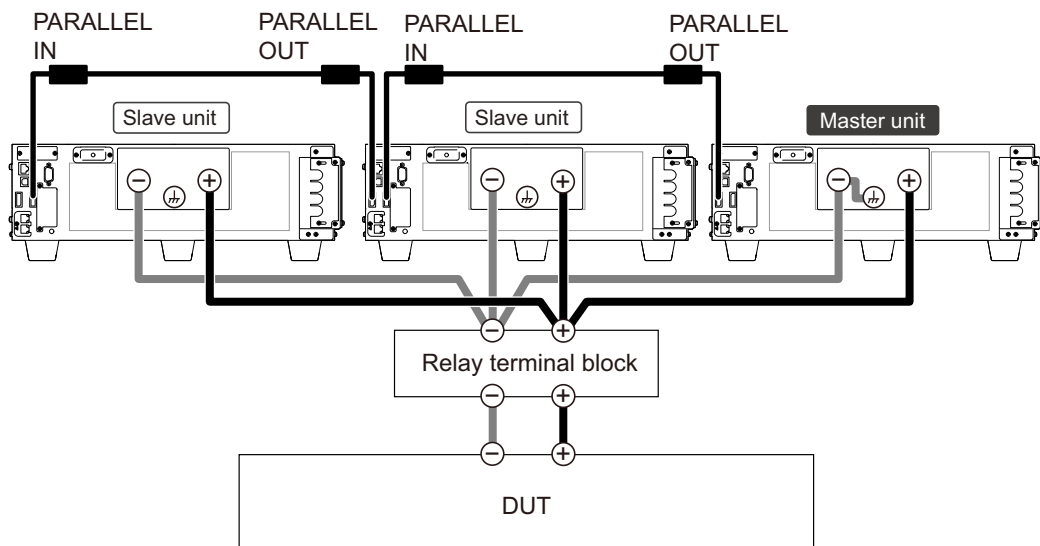

- 1** Turn off all the PXT series units that you will connect in parallel.
- 2** Connect the DC OUTPUT terminals of the PXT series units to the DUT. Refer to “Connecting the DUT” (p.30) and securely connect the DC OUTPUT terminals of multiple units in parallel. Be sure to attach a DC OUTPUT terminal cover to the DC OUTPUT terminals.

**NOTE**

- When grounding the DC OUTPUT terminal, do not ground the DUT.
- Ground only one PXT series unit, as grounding multiple units creates unwanted current paths.

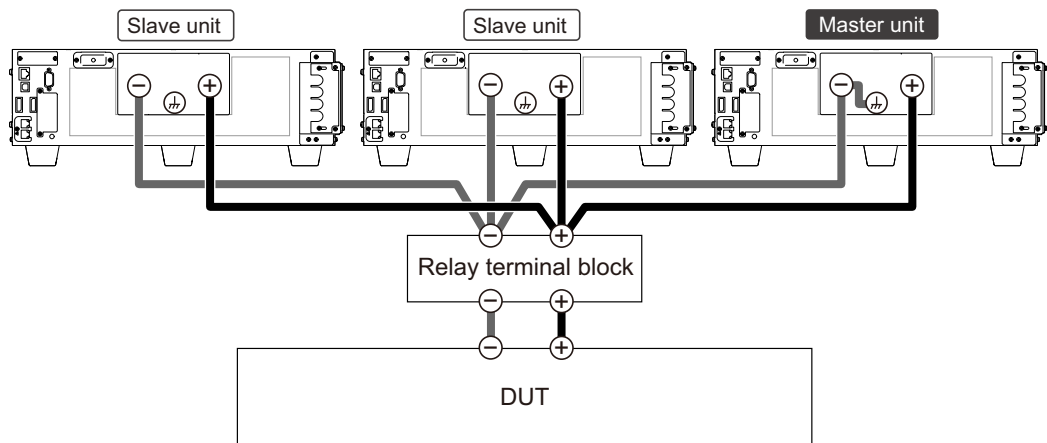

- Refer to “Grounding the DC OUTPUT terminal” (p.29) when grounding DC OUTPUT terminals.
- Connect each PXT series unit to the relay terminal block within 3 m using cables of equivalent length and cross-sectional area.
- Use load cables that are as short as possible and have sufficient thickness for the current to be used.
- Route the load cables as far as possible from the signal cables.

**3** Connect all the PXT series units to be operated in parallel with parallel operation signal cables.

Connect the PARALLEL OUT connector and IN connector with a parallel operation signal cable.

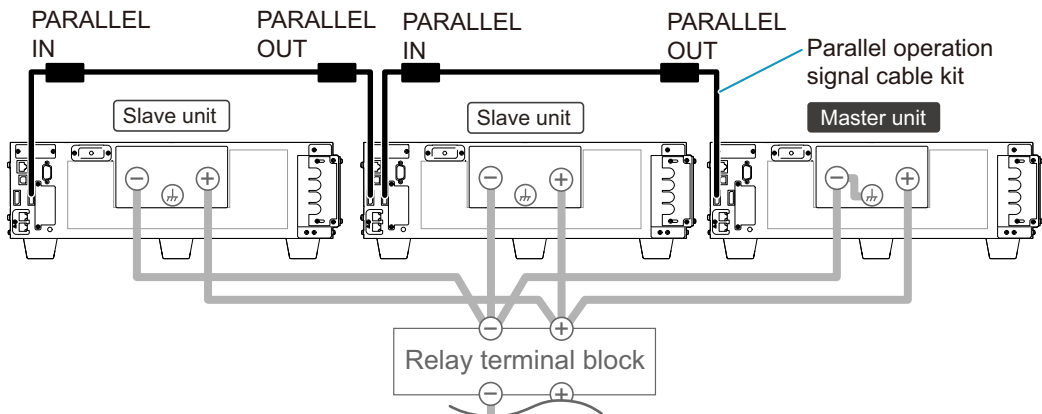

This completes the connections.

## Performing parallel operation

When connected in parallel and the power supply is turned on, the master unit automatically recognizes the slave units.

For the setting range during parallel operation, refer to “Setting Range and Resolution During Parallel Operation” (p.196)

You can turn the POWER switches of all the PXT series on or off in any order. When turning on, turn on all master and slave units within 20 seconds.

### 1 Turn on the POWER switch of all PXT series units within 20 seconds.

The master unit automatically recognizes the slave units.

Another option is to turn on all the POWER switches of the PXT series in advance to turn on the power supply all at once with an external circuit breaker.

## Behavior during parallel operation

### Slew rate and response speed

During parallel operation, the slew rate and response speed settings on the master unit are used. The slew rate increases proportionally to the number of units operating in parallel. For details, see Appendix (p.196).

If control of the PXT series becomes unstable and oscillation occurs, set the Response (p.73) to SLOW to ensure stable operation.

### Display on a slave unit

During parallel operation, the homepage of a slave unit will be displayed as follows.

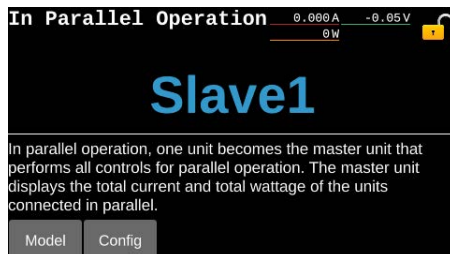

- Press Model to display the device information (p.158).
- Press Config to display the Line overvoltage protection (Line OVP) setup screen.

### Protection function

Line overvoltage protection (Line OVP) should be set to the same value for all master unit and slave units. Protection functions other than Line OVP operate with the set values of the master unit.

If an error occurs during parallel operation, an alarm is displayed on the display area of the master or slave unit and the output is turned off. Refer to “LOW alarms that occur on the master unit during parallel operation” (p.58) and “HIGH alarms that occur on the master unit or slave units during parallel operation” (p.60) for descriptions of alarms.

## Key lock

Key lock should be set on all master and slave units. Each time you press and hold the key lock icon displayed on the upper right of the display, the key lock switches between enabled and disabled.

When key lock is enabled on a slave unit, the Local key lock icon () is displayed on the upper right of the display of the slave unit.

## External Control

Among the external controls using the EXT CONT connector, monitoring of voltage and current values can be used regardless of whether the unit is a master or a slave. In current value monitoring, the master unit outputs the signal of the current value of the entire system, and the slave unit outputs the signal of the current value of the slave unit alone.

External controls other than monitoring voltage and current values can be used only on the master unit.

## Changing from parallel operation back to standalone operation

---

Turn off all the units connected for parallel operation, and then remove all connections for parallel operation. Then, connect for standalone operation.

---

### CAUTION

**PXT series and DUT may be damaged.**

- **Do not perform standalone operation with the parallel operation signal cable left connected to the PARALLEL connector.**
- 

---

### NOTE

When changing from standalone operation to parallel operation, or when changing the number of units in parallel operation, the units start up with the settings reset (p. 190). After starting, the error messages of “-314 Save/recall memory lost” and “-315 Configuration memory lost” always appear, but they are not abnormal. To remove the error messages, press CLR on the SCPI error screen (p. 170) or turn the power off and then back on.

---

# Memory Function

There is a preset memory to save only parts of the output set values and protection functions for quick switching, and a setup memory to save basic setting items.

## Memory Types

Preset memory can store output value and part of protection function. Because you can recall saved settings just by pressing a key, this feature is useful when you want to switch between the sets of values in order.

Setup memory can store all basic setup items.

### ■ Differences between Preset and Setup Memory

Parameter	Preset memories	Setup memories
Number of memory entries	20	21
Memory name	Preset.1 to Preset.20	Resume <sup>1</sup> , 1.info to 20.info
Saved setting	Output voltage value/Output current value/ Output power value Internal resistance value (IR) Over voltage protection (OVP) Under voltage protection (UVP, UVP Enable) Over current protection (OCP, Delay) Over power protection (OPP)	On/off of the output from the DC OUTPUT terminal Output voltage value/Output current value/ Output power value Output mode Response Slew Rate Priority operation mode (Priority when output is ON) Bleeder Output delay Number of I-V characteristics (Count) Internal resistance value (IR) Over voltage protection (OVP) Under voltage protection (UVP, UVP Enable) Over current protection (OCP Delay) Over power protection (OPP) Line overvoltage protection (Line OVP) Measurement trigger settings (Source, Count, Delay, Enable, Timer) Integration settings (Gate, Reset)

1. Settings at the time of turning off the power supply overwrite existing files. This is the memory used when Resume is set in Settings at Startup (p.76).

# Preset Memory

Output value and part of protection function can be saved. Because you can recall saved settings just by pressing a key, this feature is useful when you want to switch between the sets of values in order.

Item	Description
Number of memory entries	20
Memory name	Preset.1 to Preset.20
Saved setting	Output voltage value/Output current value/Output power value Internal resistance value (IR) Over voltage protection (OVP) Under voltage protection (UVP, UVP Enable) Over current protection (OCP, Delay) Over power protection (OPP)

## Saving to preset memory

You can save preset memory when the output mode (p.46) is DC, DC SEAM, or IR.

**1** Swipe to the right, or press the ◀ key on the homepage.

**2** Press Memory > Preset.

**3** Press the preset memory in the save location.

Preset memory is selected and the saved contents is displayed.

To display memory not fully displayed, swipe the display area of the memory to the left, or press the ▶ key to scroll.

To display saved contents not fully displayed, swipe the display area of the saved contents to the left, or scroll the screen with the rotary knob.

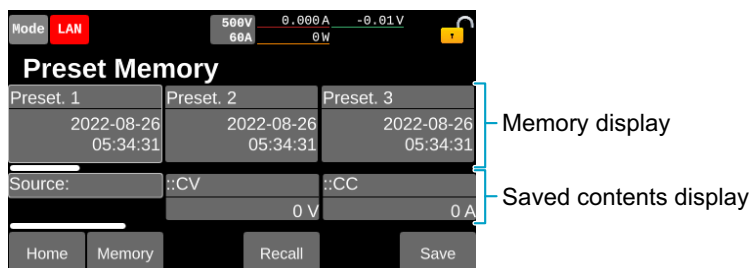

**4** Press Save.

A confirmation screen appears.

**5** Press OK.

This completes the setting.

## Recalling preset memory entries

You can recall preset memory when the output mode (p.46) is DC or IR. You cannot recall it while the output is on.

### 1 Swipe to the right, or press the ◀ key on the homepage.

A simplified screen of the preset memory will be displayed.

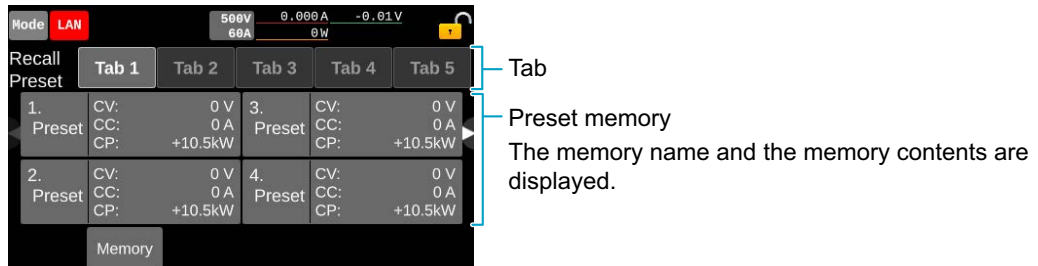

In this screen, 4 preset memories are displayed. To display other memories, press Tab at the top. Press Preset memory to recall the memory in fewer steps.

If you want to check further details before recalling, refer to the followings.

### 2 Press Memory > Preset.

### 3 Press the preset memory.

The saved contents of the preset memory is displayed at the bottom part of the memory.

To display the memory not fully displayed, swipe the display area of the memory to the left, or press the ▶ key to scroll the screen. To display saved contents not fully displayed, swipe the display area of the saved contents to the left, or scroll the screen with the rotary knob.

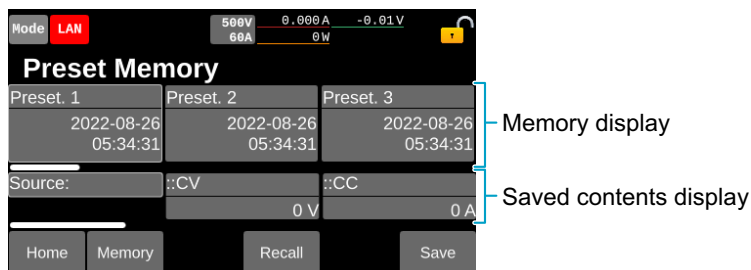

### 4 Press Recall.

If Preset Recall Conform (p.98) is marked with a check, press OK on the confirmation screen.

Setup memory will override the various settings.

This completes recalling.

## Setting the confirmation operation when recalling memories

Set to display a confirmation screen or not to recall memories.

- 1 **Swipe to the right, or press the ◀ key on the homepage.**
- 2 **Press Memory > Memory Config.**
- 3 **Press the check box for Preset Recall Conform.**

Each time you press the check box, the existence of checking changes. When checked, a confirmation screen will appear when recalling a preset memory.

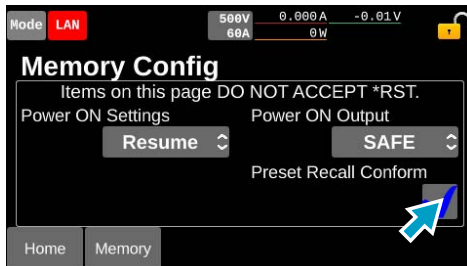

This completes the setting.

# Setup Memory

Basic setting items can be saved for later recall when necessary.

Parameter	Description	
Number of memory entries	USB memory device	21
	Internal memory	Depends on the memory size
Memory name	USB memory device	Resume <sup>1</sup> , 1.info to 20.info
	Internal memory	Any name
Saved setting	On/off of the output from the DC OUTPUT terminal Output voltage value/Output current value/Output power value Output mode Response Slew Rate Priority operation mode (Priority when output is ON) Bleeder Output delay Number of I-V characteristics (Count) Internal resistance value (IR) Over voltage protection (OVP) Under voltage protection (UVP, UVP Enable) Over current protection (OCP, Delay) Over power protection (OPP) Line overvoltage protection (Line OVP) Measurement trigger settings (Source, Count, Delay, Enable, Timer) Integration settings (Gate, Reset)	

- Settings at the time of turning off the power supply overwrite existing files. This is the memory used when Resume is set in Settings at Startup ([p.76](#)).

## Saving to the setup memory

Saves the present settings to setup memory. Data can be exported to the internal memory or to a USB memory device with a capacity up to 16 GB.

### Saving over previous settings (internal memory and USB memory)

- 1 Swipe to the right, or press the ◀ key on the homepage.
- 2 Press Memory > Setup.
- 3 When saving to a USB memory device, insert the USB memory device into the USB connector on the front panel.
- 4 Press USB or Machine.

Item	Description
USB	Save to a USB memory device. Can be selected when a USB memory device is connected to the front panel.
Machine	Data is saved in the internal memory of the PXT series.

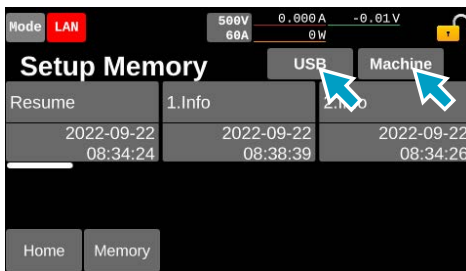

Setup memory  
The memory name and the latest save date/time are displayed.

- 5 Press the setup memory in the save destination.

The contents of the memory are displayed at the bottom part of the setup memory.

To display the memory not fully displayed, swipe the display area of the memory to the left, or press the ▶ key to scroll the screen. To display saved contents not fully displayed, swipe the display area of the saved contents to the left, or scroll the screen with the rotary knob.

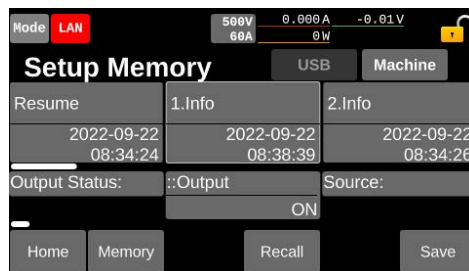

Memory display

Saved contents display

Since the Resume in the internal memory is overwritten with the set data from when the power supply was turned off, it cannot be used at the save destination for arbitrary values.

- 6 Press the Save and press OK on the confirmation screen.

The value saved to the setup memory.

## Saving to a new file (USB memory device only)

- 1 Swipe to the right, or press the ◀ key on the homepage.
- 2 Press Memory > Setup.
- 3 Insert a USB memory device into the USB port on the front panel.
- 4 Press USB.

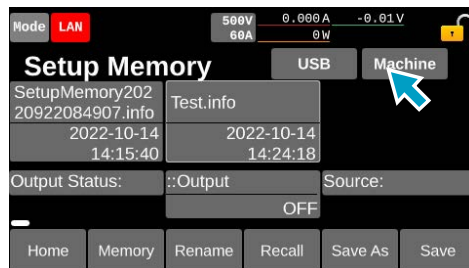

Setup memory memory  
The memory name and the latest save date/time are displayed.

- 5 Press Save As.  
The present settings are saved.

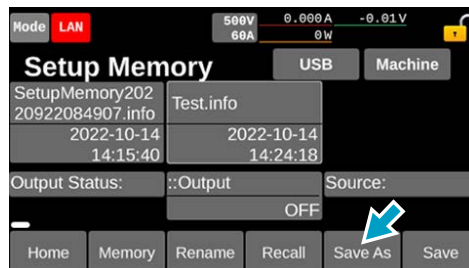

- 6 Input an arbitrary memory name and press OK.  
You can enter up to 63 characters for the memory name.

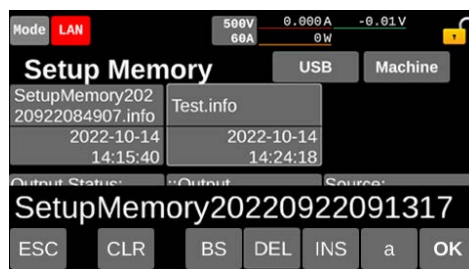

The value saved to the setup memory.

## Changing the memory name (USB memory device only)

- 1 Swipe to the right, or press the ◀ key on the homepage.
- 2 Press Memory > Setup.
- 3 Insert a USB memory device into the USB port on the front panel.
- 4 Press USB.

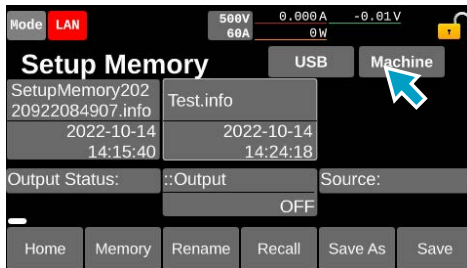

Setup memory memory  
The memory name and the latest save date/time are displayed.

- 5 Select any memory and press Rename.

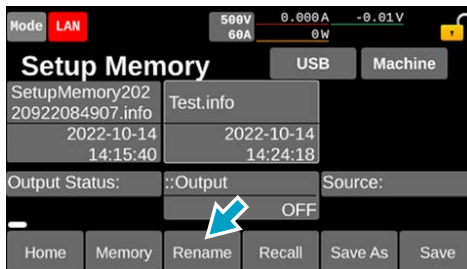

- 6 Input an arbitrary memory name and press OK.

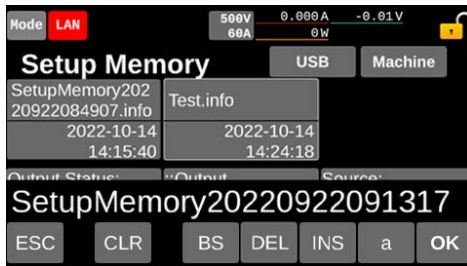

The memory name is changed.

## Recalling the setup memory

It can be recalled when output is off.

### NOTE

When a memory whose output is set to ON is recalled while Output ON Delay (p.75) is set at other than zero second, the output shall be turned on at the elapsed time set by Output ON Delay.

- 1 **Swipe to the right, or press the ◀ key on the homepage.**
- 2 **Press Memory > Setup.**
- 3 **When recalling out of the USB memory device, insert the USB memory device into the USB connector on the front panel.**
- 4 **Press USB or Machine.**

Item	Description
USB	Recalls out of the USB memory device. Can be selected when a USB memory device is connected to the front panel.
Machine	Data is recalled out of the internal memory of the PXT series.

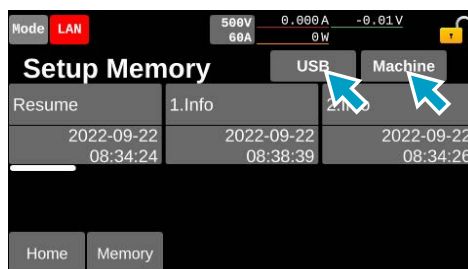

Setup memory  
The memory name and the latest save date/time are displayed.

The data set at the previous power supply off is stored in the Resume memory.

- 5 **Press the setup memory to be recalled.**

The contents of the memory are displayed at the bottom part of the setup memory.

To display the memory not fully displayed, swipe the display area of the memory to the left, or press the ▶ key to scroll the screen. To display saved contents not fully displayed, swipe the display area of the saved contents to the left, or scroll the screen with the rotary knob.

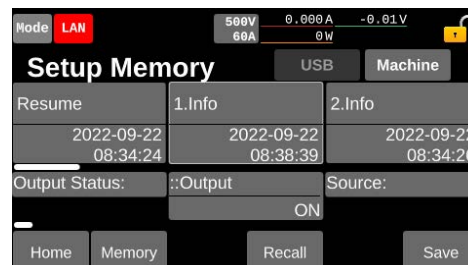

Memory display

Saved contents display

- 6 **Press the Recall and press OK on the confirmation screen.**

The setup memory entry is recalled.

### ■ When the memory cannot be recalled

When values that cannot be set in the PXT series currently in use are saved in the setup memory, an error screen is displayed. By pressing OK, the setting returns to the one before recalling.

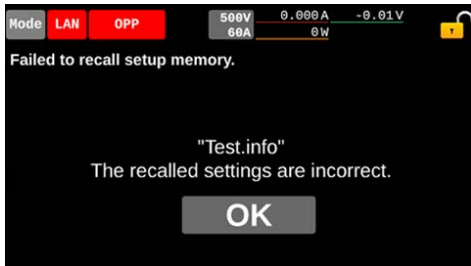

## When the setup memory is not displayed (USB memory device only)

---

Out of the setup memory saved on USB, memory falling under the following conditions will not appear on the display.

- In the case of changing the file extension (.info) of the setup memory file
- In the case of importing with a PXT series with an older system version than that of the saved PXT series
- In the case that the model name is different from that of the saved PXT series
- In the case that the rated voltage is different from that of the saved PXT series

# Sequence Function

## Overview of the Sequence Function

Sequence is a function that executes a sequence of operations set in advance.

### Configuration of sequence

A sequence consists of programs, steps and chains. A program is a collection of steps. Steps are executed in order one at a time, starting from step 1. When the loop has been specified in the program, the program will be repeated for the number of loops, and when the last step is completed, the program will end.

To execute sequences, register one or more programs in the chain. Multiple programs registered in chains will be executed consecutively. When all programs registered in chain are executed, the sequence ends.



Programs can be created up to 30 programs in total.  
As for the number of steps, up to 10,000 can be created in total for all programs.

Example: When the number of loops in program 1 is 2

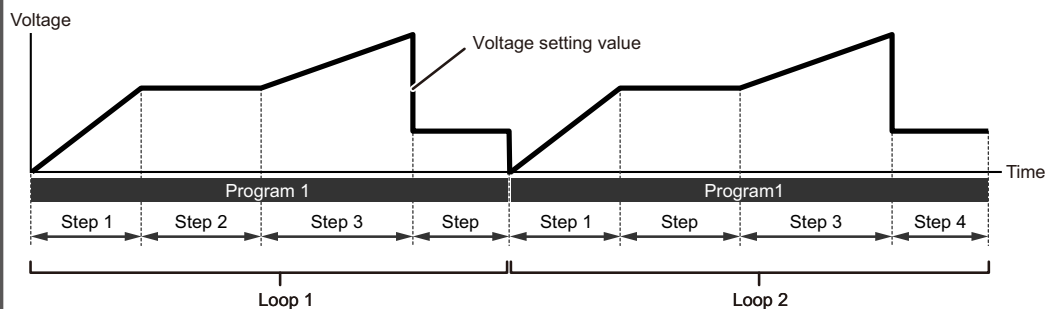

## Main functions

Setting range	Setting	Description
For each program	Number of loops of program	1 to 100000 repetitions, or infinite repetitions.
	Trigger	Trigger wait settings
By step	Output value	Voltage, current, resistance, power.
	Transition at the time of operation mode change	Function of transition to the next step (ON/OFF) when the operation mode changes while executing steps
	Step execution time	0.001 s to 3600000.000 s (1000 h)
	Output state ON/OFF	Output ON / OFF
	Output value transition method	Select output value transition method from the step or the slope in line with operation mode.
	Trigger	Trigger output and trigger wait settings

# Program Configuration

## Displaying the program list screen

When pressing Sequence > Select edit on the homepage, the program list screen is displayed.

When the program is not fully displayed on the screen, swipe the program to the left and right and press the ◀▶ key or scroll with the rotary knob. The following figure shows an example when three programs are being registered.

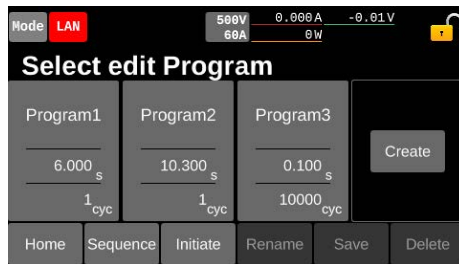

Program

Execution time and the number of loops are displayed.

## Creating a program

First, create an empty program without registering any steps.

**1 Press Sequence > Select edit on the homepage.**  
The program list screen is displayed.

**2 Press Create.**  
When Create is not displayed, swipe the program to the left until Create is displayed.

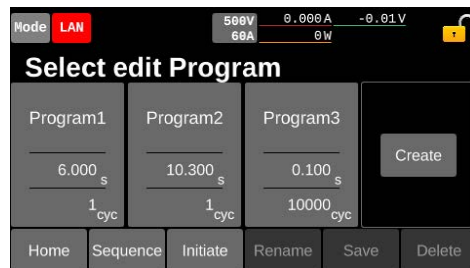

Program

An empty program is created.

To register steps in the program, see “Setting Steps” (p.113).

## Changing program settings

When holding down a program on the program list screen (p.107) or pressing program and pressing the selected program again, the program setup screen is displayed.



Pressing Select edit returns to the program list screen.

On the program setup screen, the following values can be changed.

Item	Description
Loop	Set the number of loops of the program. (p.108)
Wait Trig	Set the conditions for starting the program. (p.109)

### Loop count

Set the number of loops of the program. Press the input field for Loop to select the value with the display or the rotary knob.

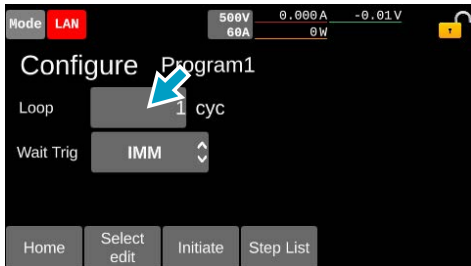

Setting range: 0 to 100000

Setting it to 0 will make the loop count infinite, and INFINITY will be displayed.

## Trigger wait settings

Set the condition for starting the execution of sequences (trigger source).

When inputting the set trigger source on the sequence execution screen ([p.121](#)), the sequence will be executed. Press the input field for Wait Trig to select the value with the display.

### NOTE

In the programs registered in the second and later order of the chain, the trigger wait settings will become invalid.

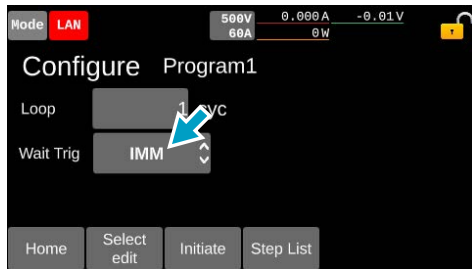

Item	Description
IMM	Sequence starts at the following timing: <ul style="list-style-type: none"> <li>• When pressing Run on the sequence execution screen (<a href="#">p.123</a>)</li> <li>• When inputting SEQ RUN with the external control (<a href="#">p.140</a>)</li> <li>• When receiving INITiate command via remote control</li> </ul>
BUS	The sequence is started at the time of receiving the software trigger (*TRG) by remote control.
EXT	The sequence is started at the time the signal is input to the terminal where the general-purpose digital input of the external control ( <a href="#">p.140</a> ) is set to SEQ TRIG IN.
MSYN	The sequence is started at the time of pressing Msync on the display of the PXT series connected in synchronization. Or, the sequence is started at the time of receiving the sync signal for the sequence by remote control.

## Changing a program name

- 1 Press Sequence > Select edit on the homepage.**  
The program list screen is displayed.

- 2 Press a program.**  
The program is selected.

- 3 Press Rename.**

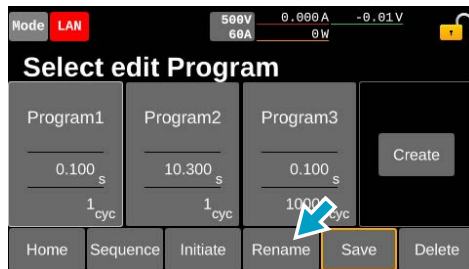

- 4 Input the program name with the display or rotary knob and press OK.**  
Naming convention: Alphabet characters A-Za-z, numbers 0-9, dot (.), comma (,), parentheses ( ), brackets [], braces </>, and (&), dollar (\$), hash (#), caret (^), percent (%), equal (=), hyphen (-), plus (+), underscore (\_), space ( ), case-sensitive, up to 32 characters.  
This completes the setting.

### NOTE

The order of the programs is rearranged in numerical and alphabetical order when the power supply of the PXT series is turned off and then on again.

## Saving the program

When a program is saved, the program is saved even after the power supply of the PXT series is turned off. When the total number of steps of all saved programs is large, it will take longer time to turn the power supply of the PXT series on (as a reference, it takes about 15 minutes for 10000 steps).

**1 Press Sequence > Select edit on the homepage.**

The program list screen is displayed.

**2 Press a program.**

The program is selected.

**3 Press Save.**

When a program is not yet saved, a yellow frame is displayed on the Program and Save.

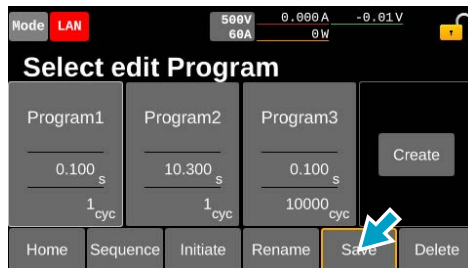

This completes saving.

## Deleting a program

- 1 Press Sequence > Select edit on the home page.**  
The program list screen is displayed.
- 2 Press a program.**  
The program is selected.
- 3 Press Delete.**

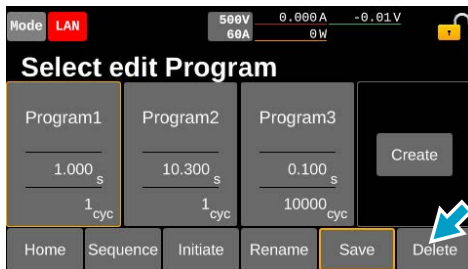

A confirmation screen appears.

- 4 Press OK.**  
The program is now deleted.

# Setting Steps

## Displaying the step list screen

### NOTE

If the number of steps of the program increases, it will take more time to display the step list. (Approximately 30 seconds for 10000 steps as a rough guide).

- 1 **Press Sequence > Select edit on the homepage.**  
The program list screen is displayed.
- 2 **Hold down the program. Or, press the program and press the selected program again.**  
The program setup screen is displayed.
- 3 **Press Step List.**

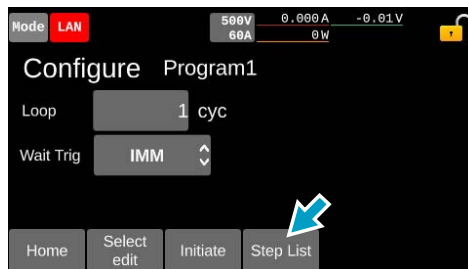

The step list screen is displayed.

When the step is not fully displayed on the screen, swipe the step to the left and right and press the ◀▶ key or scroll with the rotary knob. The following figure shows an example when three steps are being registered.



Steps  
Execution time and output value are displayed.

Pressing Configure program returns to the program setup screen.

## Creating steps

### New preparation

When pressing Insert on the step list screen, a copy of the last step will be inserted as a new step.  
When Insert is not displayed, swipe the step list to the left and press the ► key or scroll with the rotary knob.

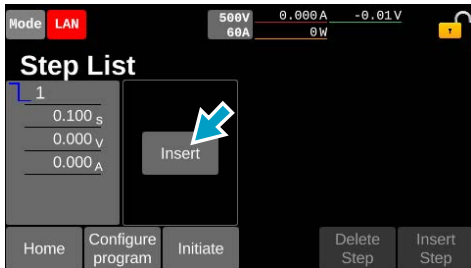

### Inserting the step

- 1 Press the step on the step list screen.  
Step is selected.
- 2 Press Insert Step.



The selected steps are copied and inserted.

## Changing the step settings

When pressing a step on the step list screen and pressing the selected step again, the step setup screen is displayed.

To display settings not fully displayed on the screen, swipe the step setting area to the left or right, or press the ◀▶ keys to scroll the screen.

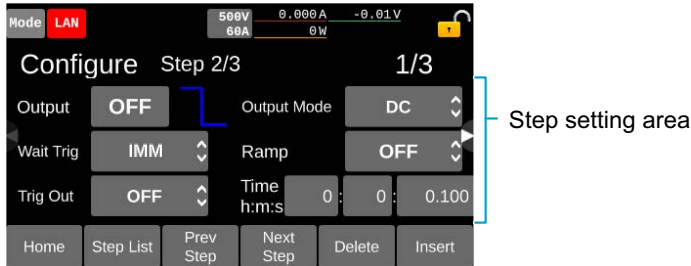

Pressing Step List returns to the step list screen.

Pressing Prev Step or Next Step will switch to the previous/next step setup screen.

On the step setup screen, the following values can be edited.

Item	Description
Output	Set whether to output during step. <a href="#">(p.116)</a>
Wait Trig	Set the conditions for starting the step. <a href="#">(p.116)</a>
Trig Out	Set whether to perform trigger output when starting the step. <a href="#">(p.117)</a>
Output Mode	Set whether to perform normal output or use the sine function. <a href="#">(p.117)</a>
Ramp	Set whether the transition from the previous step to the next will be in step or slope. <a href="#">(p.118)</a> In the case of step 1, this set value is ignored.
Time	Set the step execution time. <a href="#">(p.118)</a>
CC	Set the current. <a href="#">(p.119)</a>
CV	Set the voltage. <a href="#">(p.119)</a>
CP	Set the power. <a href="#">(p.119)</a>
IR	Set the resistance. <a href="#">(p.119)</a>
Output Mode Transition	Set whether to perform transition to the next step automatically when the operation mode changes during step. <a href="#">(p.119)</a>

## Volt setting

Set whether to output during step. ON and OFF are switched every time the input field for Output is pressed. Output Delay (p.75) settings are not reflected.

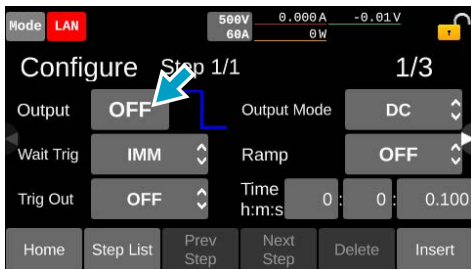

Item	Description
ON	Output is done.
OFF	Output is not done.

## Trigger wait settings

Set the conditions for starting the step. Press the input field for Wait Trig to select the value with the display.

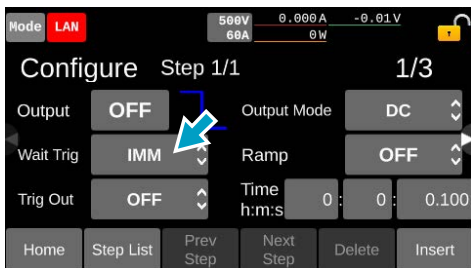

Item	Description
IMM	Starts the step immediately.
BUS	The step is started at the time the *TRG command is input by remote control.
EXT	The step is started at the time the signal is input to the terminal set to SEQ TRIG IN in the general-purpose digital input (p.140).
MSYN	The step is started at the time of pressing Msync on the display of the PXT series connected in synchronization.

## Trigger output setting

Set whether to perform trigger output when starting the step. Press the input field for Trig Out to select the value with the display.

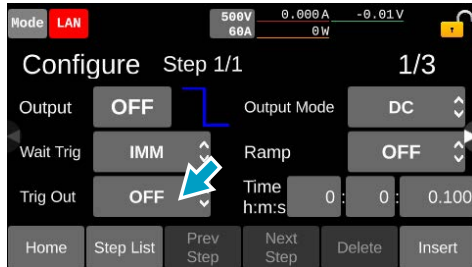

Item	Description
OFF	Trigger is not output.
PULSE	The trigger is output at the time of step start from the terminal where SEQ TRIG OUT is set by the general-purpose digital output ( <a href="#">p.142</a> ).
DC	The trigger is output while executing steps from the terminal where SEQ TRIG OUT is set by the general-purpose digital output ( <a href="#">p.142</a> ).

## Output mode setting

Set whether to perform normal output or use the sine function. Press the input field for Output Mode to select the value with the display.



Item	Description
DC	Current and power are controlled by source and sink side values, respectively.
CV IR	Enables the internal resistance function.

## Output value transition method

Set whether the transition from the previous step to the next will be in step or slope. Press the input field for Ramp to select the value with the display.



Item	Description
OFF	Transition is performed in steps from the set value of the previous step.
CV RAMP	Transition is performed in CV mode in slope from the set value of the previous step.
CC RAMP	Transition is performed in CC mode in slope from the set value of the previous step.
CP RAMP	Transition is performed in CP mode in slope from the set value of the previous step.

## Step execution time

Set the step execution time. Press the input field for Time to enter h (hours), m (minutes), and s (seconds) on the display or with the rotary knob.

Entering a value of 60 or more for m or s will move up the display automatically.

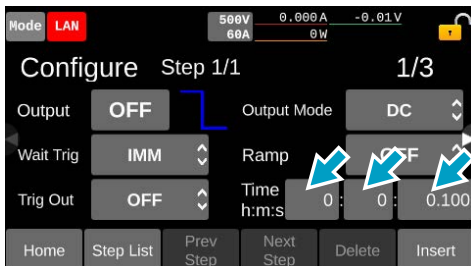

Setting range: 0:0:0.001 to 1000:0:0.000 (0.001 seconds to 1000 hours)

## Output value setting

Set voltage, current, power and resistance. Press the input field for each value to select the value with the display or the rotary knob.

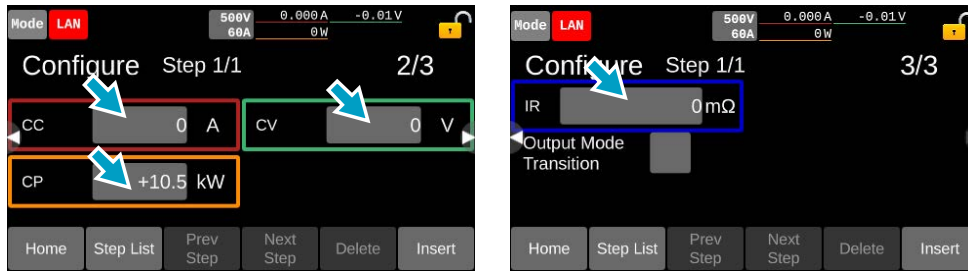

Item	Description
CC	Input current in CC mode.
CV	Input voltage in CV mode.
CP	Input power in CP mode.
IR	Input resistance in CV mode.

## Transition of step at the time of operation mode change

Set whether to perform transition to the next step automatically when the operation mode changes during step.

Press the input field for Output Mode Transition and change the existence of the checks on the display.

When checked, transition to the next step occurs automatically approximately 10 ms after the operation mode changes during a step.



## Deleting a step

There are three ways to delete a step.

- Press Delete Step in the state where the step is selected by pressing the step on the step list screen.



- Press Delete in the state where the multiple steps are pressed and selected by holding down the steps on the step list screen.

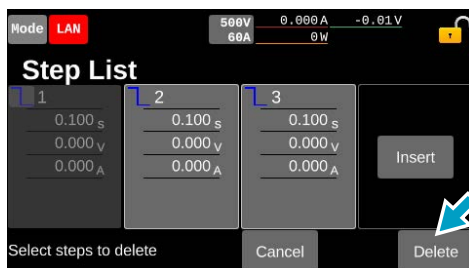

- Press Delete on the step setup screen.



# Executing, Pausing, and Stopping Sequences

When the program and step settings are complete, register the program in the chain and execute the sequence. You can pause or stop the sequence while it is running. By setting triggers ([p.109](#)), the start timing of the sequence can be controlled.

## Registering the program in the chain

Program is executed in the order of registration in the chain.

### NOTE

- Unlock the chain and register it again in the following case:
  - When wishing to change the order of the programs registered in the chain
- Chain is unlocked in the following cases:
  - When turning off the power supply of the PXT series
  - When creating a new program
  - When changing settings of/deleting a program registered in the chain or a program not registered in the chain

### 1 Press Sequence > Initiate on the homepage.

The sequence execute screen will be displayed.

The same screen is displayed when Initiate is pressed on the program list screen ([p.107](#)).

### 2 Swipe the display to the left, or press the ► key.

The chain creation screen is displayed.

Swipe the list to the left when the created program is not fully displayed. When the program registered in the chain is not fully displayed, swipe the list to the left, or scroll the screen with the rotary knob.

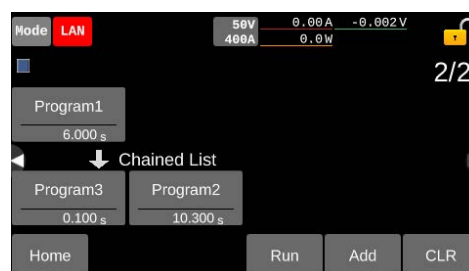

List of programs already created  
Program name and execution time are displayed.

List of programs registered in the chain  
Program name and execution time are displayed.

### 3 Press the program desired to be registered in the chain on the list of programs already created.

The program is selected.

### 4 Press Add.

Program is registered in the chain.

### 5 Repeat Step 3 and Step 4.

In the case of executing a sequence, the programs on the left side of the Chained List are executed in order. Operation completed.

## Unlocking a chain

- 1 Press CLR on the chain creation screen.



All programs registered in the chain is unlocked.

## Executing sequences

Programs registered in the chain are executed in order.

During running or pausing a sequence, the Run icon ( **RUN** ) appears in the upper right corner on the display.

### 1 Press Run on the sequence execution screen or on the chain creation screen.



Screens during program execution are displayed.

To confirm steps not fully displayed, swipe the step list to the left and right, or scroll the screen with the rotary knob.

Upper row: Present loop count  
Lower row: All loop count

: In pause  
 : In execution

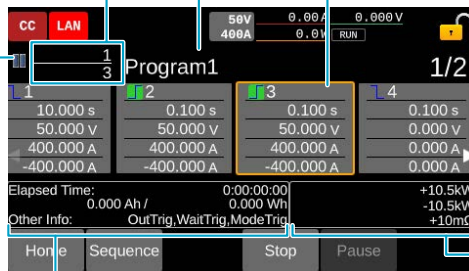

A frame is displayed at the present step.  
Green: in execution  
Orange: in pause

Step list  
Execution time and value are displayed.

Values of CP and IR

Elapsed time, integration value, and trigger information (displayed when Wait Trig, Trig Out, or Output Mode Transition is enabled)

## NOTE

- To synchronize the elapsed time and integrated values with the sequence execution, set "Conditions for starting/stopping integration" (p.53) to PROG RUN.
- If the waveform is not output as set after the sequence starts, check the following.
  - Set the output voltage value to 1 V or more, and the output current value to 1 A or more on the homepage.
  - If the waveform is not output in the set time, set the output setting value of the step (p.119) to 20 % or more of the rating. The operation mode may have transitioned.

### ■ Synchronization of the start timing of a program or a step

The start timing of a program or a step can be synchronized with the PXT series connected in synchronization. For details, see "Synchronization of the program start" (p.88) and "Synchronization of the step start" (p.89).

### ■ Start timing of a program or step is controlled by a trigger

The timing to start a program can be controlled by setting a trigger wait (p.109) in the program.  
The timing to start a step can be controlled by setting a trigger wait (p.116) in the step.

## Stops the sequence

If you press the OUTPUT key on the front panel or press Stop on the sequence execution screen while a sequence is running, the sequence will stop and the outputs will be turned off.

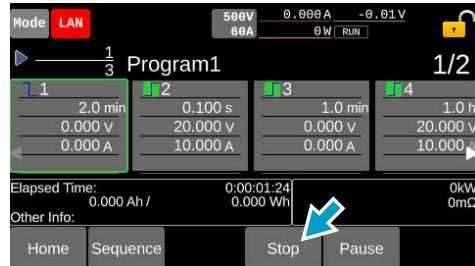
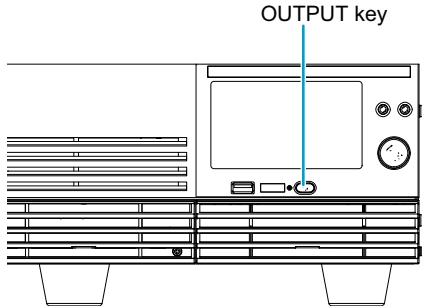

## Pausing a sequence

Pressing the Pause while a step is running will pause the sequence. Press Resume to resume the sequence.



While a sequence is running

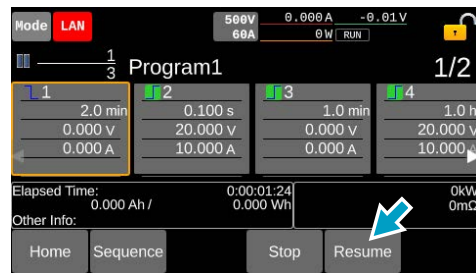

Sequence paused

# Exporting and Importing Programs

Programs saved in the internal memory can be exported to a USB memory device with a capacity up to 16 GB. Programs exported to a USB memory device can also be imported into the internal memory.

## Exporting programs to a USB memory device

Save the program to the root folder of the USB memory device.

**1** Insert a USB memory device into the USB connector on the front panel.

**2** Press **Sequence > Export** on the homepage.

Program exporting screen is displayed.

To display programs not fully displayed on the screen, swipe the program list to the left or right, or press the ◀/▶ keys to scroll the screen.

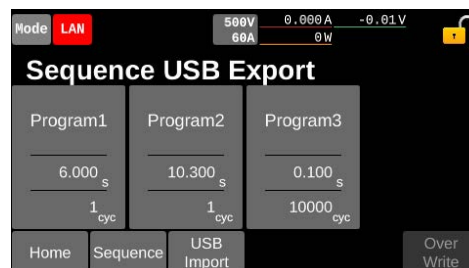

The program list saved in the internal memory.  
The execution time and the number of loops are displayed.

In the case of pressing USB Import, the display switches to the program importing screen.

**3** Press a program.

The program is selected.

**4** Press **OverWrite**.

Overwrite programs to a USB memory device.

Operation completed.

## Importing programs from a USB memory device

### NOTE

If the number of steps is large, loading will take more time (approximately 5 minutes for 10000 steps as a rough guide).

- 1** Insert a USB memory device into the USB connector on the front panel.
- 2** Press **Sequence > Import** on the homepage.  
Program importing screen is displayed.
- 3** Press **Load USB**.  
The list of programs saved to the USB memory device is displayed.  
To display programs not fully displayed on the screen, swipe the program list to the left or right, or press the ◀▶ keys to scroll the screen.

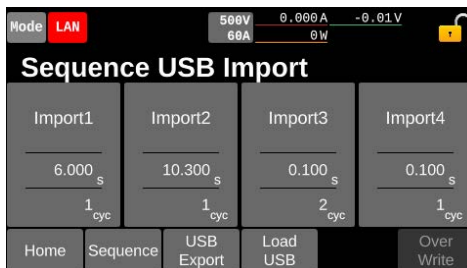

The program list saved in the USB memory.  
The execution time and the number of loops are displayed.

In the case of pressing USB Export, the display switches to the program exporting screen.

- 4** Press a program.  
The program is selected.
- 5** Press **OverWrite**.  
Overwrite programs to the internal memory.  
The loaded program will be displayed at the end of the program list.  
Operation completed.

## In the case that the program cannot be used

When the output set values of the saved program (voltage, current, or power) exceed the rated values, the program is grayed out in the PXT series and cannot be selected.

The program will not be displayed in the PXT series in the following cases:

- In the case of changing the file extension (.json) of the program file
- In the case of importing with a PXT series with an older system version than that of the saved PXT series
- In the case that the rated voltage is different from that of the saved PXT series
- When the number of programs exceeds 30
- When the total number of steps of all programs exceeds 10000 steps

# External Control

## Overview of the External Control

An external device can control PXT series using the EXT CONT connector on the rear panel. Outline of the controllable functions are as follows. An arbitrary function can be assigned to the general-purpose digital input and output terminals.

Method	Function	Connection method	Setting procedure
Analog input	Set voltage and current	<a href="#">p.129</a>	<a href="#">p.134</a>
Analog output	Monitor the voltage and current values	<a href="#">p.130</a>	<a href="#">p.134</a>
General-purpose digital input (Ch.1 to Ch.5)	<ul style="list-style-type: none"><li>• On/off of the output from the DC OUTPUT terminal</li><li>• LOW alarm occurrence / clearance</li><li>• Starting/stopping integration measurement</li><li>• Reset integrated value</li><li>• Input the measurement trigger</li><li>• Recall settings from preset memory</li></ul>	<a href="#">p.131</a>	<a href="#">p.139</a>
Digital input (Ch.6)	HIGH alarm occurrence (fixed)	<a href="#">p.131</a>	—
General-purpose digital output (Ch.1 to Ch.6)	<ul style="list-style-type: none"><li>• Monitor the output state from the DC OUTPUT terminal</li><li>• Monitor the power on</li><li>• Monitor the alarm</li><li>• Monitor the operation mode</li><li>• Monitor the preset memory</li></ul>	<a href="#">p.132</a>	<a href="#">p.139</a>

# EXT CONT Connector Pin Arrangement

EXT CONT connector pin number

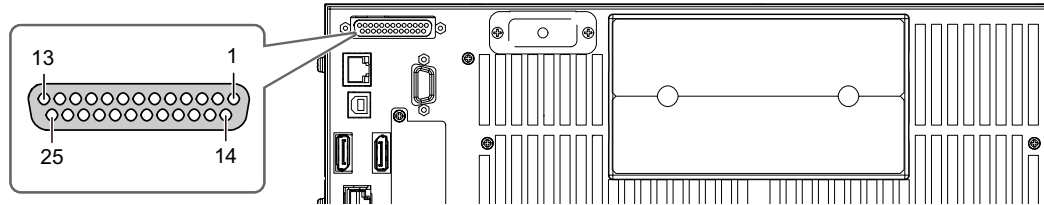

Terminal No.	Method	I/O	Name	Description
1	Digital	O	OUT Ch.1	General-purpose output terminal
2	Digital	O	OUT Ch.2	General-purpose output terminal
3	Digital	O	OUT Ch.3	General-purpose output terminal
4	–	–	DO COM	Digital output common
5	–	–	DI COM	Digital input common
6	Digital	I	IN Ch.1	General-purpose input terminal
7	Digital	I	IN Ch.2	General-purpose input terminal
8	Digital	I	IN Ch.3	General-purpose input terminal
9	–	O	+12 V OUT	12 V reference voltage available for digital input
10	–	–	–	Not used
11	–	–	A COM	Analog signal common
12	Analog	O	VMON	Voltage monitor
13	Analog	O	IMON	Current monitor
14	Digital	O	OUT Ch.4	General-purpose output terminal
15	Digital	O	OUT Ch.5	General-purpose output terminal
16	Digital	O	OUT Ch.6	General-purpose output terminal
17	–	–	DO COM	Digital output common
18	–	–	DI COM	Digital input common
19	Digital	I	IN Ch.4	General-purpose input terminal
20	Digital	I	IN Ch.5	General-purpose input terminal
21	Digital	I	H ALARM IN	HIGH alarm EXT HIGH occurrence
22	–	–	12 V COM	12 V reference voltage common
23	–	–	A COM	Analog signal common
24	Analog	I	EXT CV	Voltage control in the constant voltage mode
25	Analog	I	EXT CC/CP	Current control in the constant current / power modes

## Connecting to the EXT CONT Connector

To connect the signal cable to the EXT CONT connector, use the external control connector (made by Hirose Electric) that comes with the product. For details on how to use the connectors, see the Hirose Electric catalog. For information about how to obtain these tools or replacement parts, contact your Kikusui agent or distributor.

Name	Product name	Notes
Connector	HDBB-25P(05)	Wire diameter: AWG28 to AWG20 Solder wiring method. Use a soldering iron of 40 W or less for soldering, and complete the operation within 4 seconds.
Plug case	HDB-CTH(4-40)(10)	–

When performing parallel operation, connect the signal cable only to the EXT CONT connector of the master unit.

## Connecting to the analog input terminal

For analog input, the voltage and current values output from the DC OUTPUT terminal can be set by external voltage.

### ⚠ CAUTION

**PXT series and DUT may be damaged.**

- Do not input voltages outside the control voltage range to the analog input terminal and digital input terminal.

For the input specifications, refer to Specifications (p. 184).

### Connection method

Turn off power, and connect the external voltage to the EXT CONT connector referring to the followings. The analog input terminal and the DC OUTPUT terminal are isolated from each other.

Controls	Terminal to be connected
Voltage control in the constant voltage mode	Between the terminals No.24 and 23
Current control in the constant current / power modes	Between the terminals No.25 and 23

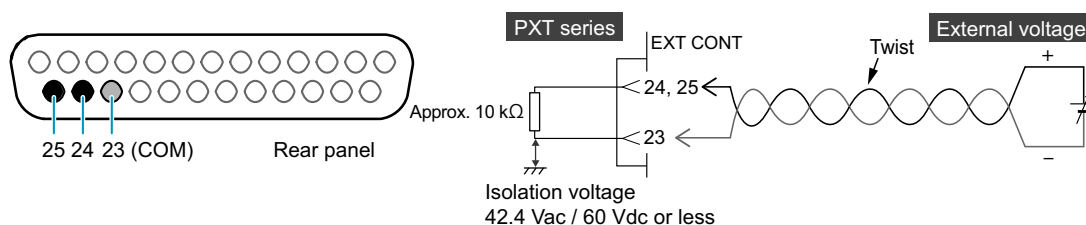

### Settings related to analog input

- Enabling analog input/output (p. 134)
- Setting the input range of the voltage control signal (p. 135)
- Setting the input range of the current/power control signal (p. 136)

## Connecting to the analog output terminal

For analog output, the voltage and current values output from the DC OUTPUT terminal can be monitored.

### NOTE

Transient current fluctuations cause a difference between the current monitor value and the actual current.

### Connection method

Turn off power, and connect the external voltage to the EXT CONT connector referring to the followings. The analog output terminal and the DC OUTPUT terminal are isolated from each other.

Controls	Terminal to be connected
Monitoring of voltage	Between the terminals No.12 and 11
Monitoring of current	Between the terminals No.13 and 11

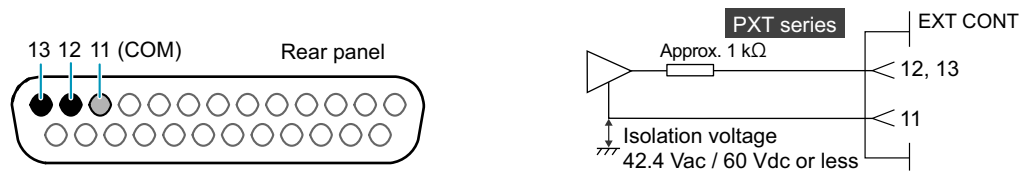

For the output specifications, refer to Specifications (p.184).

### Settings related to analog output

- Enabling analog input/output (p.134)
- Setting the output range of the voltage control signal (p.137)
- Setting the output range of the current control signal (p.138)

## Connecting to the digital input terminal

Digital input includes general-purpose digital input terminals (Ch.1 to Ch.5) that allow you to arbitrarily select a function to be controlled, and terminals that generate a HIGH alarm (Ch.6).

For details on the functions that can be selected by Ch.1 to Ch.5, refer to “Setting the functions of the general-purpose digital inputs” (p.140).

### ⚠ CAUTION

**PXT series and DUT may be damaged.**

- **Do not input voltages outside the control voltage range to the analog input terminal and digital input terminal.**

For the input specifications, refer to Specifications (p.184).

### Connection method

Turn off power of PXT series, and connect the external contact to the EXT CONT connector.

Controls	Terminal to be connected
General-purpose digital input	It depends on the channel to use. Between the terminals No.6 (Ch.1), No.7 (Ch.2), No.8 (Ch.3), No.19 (Ch.4), or No.20 (Ch.5), and No.5 or No.18
Generate HIGH alarm EXT HIGH (p.59)	Between the terminals No.21, and No.5 or No.18

Power supply is necessary to use digital input. The 12 V reference voltage of the EXT CONT connector or arbitrary external power supply can be used.

The following drawings show an example of connection using the 12 V reference voltage (No. 9 and No. 22) of the EXT CONT connector as a power supply.

Rear panel

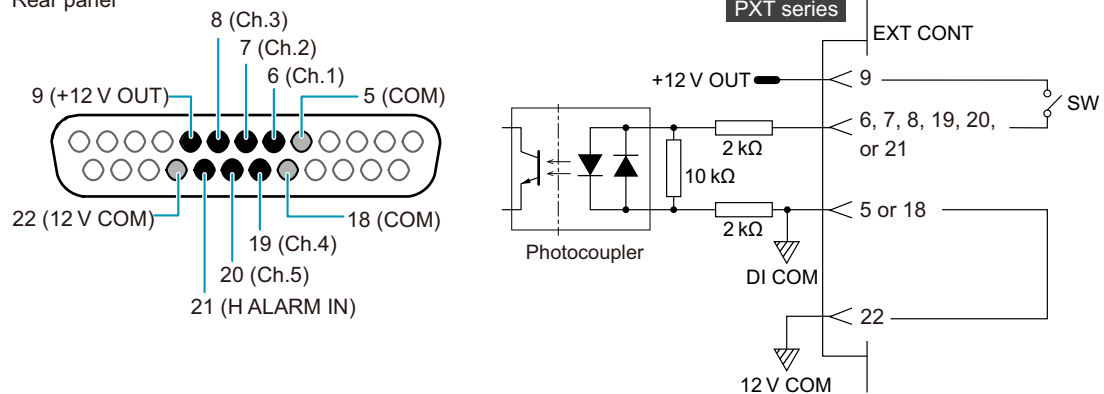

### NOTE

Since the digital input terminals are compatible with both positive and negative common, you can also set DI COM to positive common.

### Input specifications

Item	Specifications
Input resistance	4 kΩ
Input ON current	1.5 mA or more
Input OFF current	0.1 mA or less
External circuit power supply range	12 to 24 Vdc (±10 %)
Response speed	Within 200 μsec (response time of photocoupler)

## Connecting to the digital output terminal

These are general-purpose digital output terminals (Ch.1 to Ch.6) you can arbitrarily select a function to be controlled.

For details on the functions that can be selected by Ch.1 to Ch.6, refer to “Setting the functions of the general-purpose digital output” (p.142).

### Connection method

It depends on the channel to use. Turn off power, and connect a signal cable between the terminals No.1 (Ch.1), No.2 (Ch.2), No.3 (Ch.3), No.14 (Ch.4), No.15 (Ch.5), or No.16 (Ch.6), and No.4 or No.17 of the EXT CONT connector.

For details on output specifications of each channel, see below.

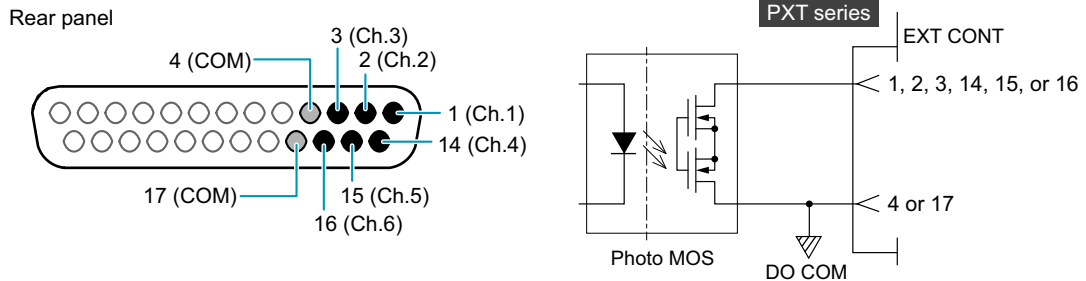

### NOTE

Since the digital output terminals are compatible with both positive and negative common, you can also set DO COM to positive common.

### Output specifications

Item	Ch.1 to Ch.5	Ch.6
Output pressure-resistance	Max. ±42.4 V	Max. ±30 V
Output current	Maximum 80 mA (per channel)	Maximum 1.2 A
Output ON resistance	16.0 Ω or less	0.25 Ω or less
Output OFF leakage current	1.0 μA or less	1.0 μA or less
Response speed	Within 2.0 msec	Within 3.0 msec

## Connecting to the EXT CONT connector

### Storing the protection plate

By factory default, the protection plate is mounted on the EXT CONT connector. When using the EXT CONT connector, keep the removed protection plate in a safe place. If you are not using the EXT CONT connector, attach the protection plate for your safety and to prevent external disturbances. If it is damaged or lost, contact your Kikusui agent or distributor.

### Connecting an external control connector

#### NOTE

- To prevent noise interference, use twisted wires for the signal cables.
- Use a highly stable power supply that has low noise for the external controller.

**1** Turn the POWER switch off.

**2** Remove the protection plate of the EXT CONT connector.

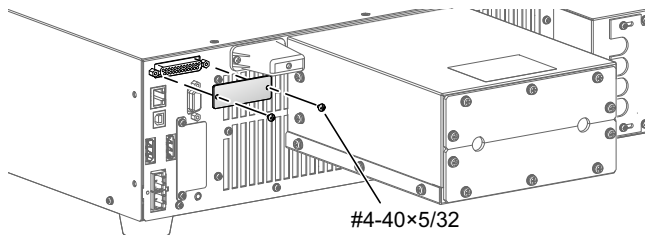

**3** Connect the external control connector to the EXT CONT connector.

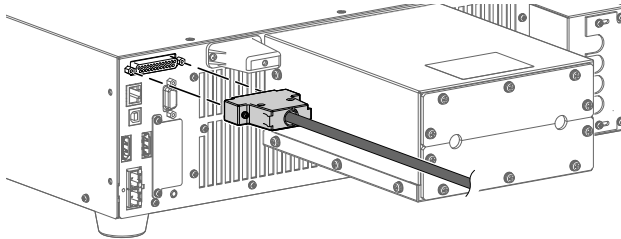

**4** Connect the signal cable to the external controller.  
This completes the external control connection procedure.

# Setting Analog Input/Output

The output voltage, output current, and output power can be controlled by external voltage using the analog input terminals (p. 129) and analog output terminals (p. 130) of the EXT CONT connector.

## Enabling analog input/output

To control the output voltage, output current, or output power with external control, set the output function of the respective operation modes to External Control (EXT).

Item		Description
CV	EXT	The voltage is controlled by external voltage.
CC	EXT	The current is controlled by external voltage.
CP	EXT	The power is controlled by external voltage.

### NOTE

You cannot set CC and CP to EXT simultaneously.

- 1 Turn off the output from the DC OUTPUT terminal.
- 2 Press Output Setting > Output Mode on the homepage.
- 3 Press the input field for CV, CC or CP.

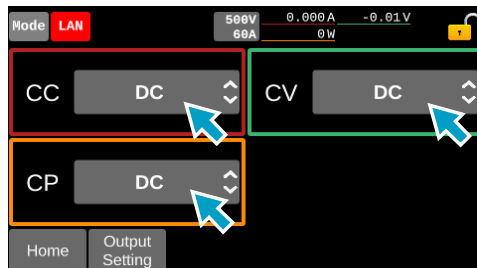

- 4 Press EXT.  
This completes the setting.

## Setting the input range of the voltage control signal

When an external voltage is applied to the analog input terminal (p. 129), a voltage value proportional to the change is obtained.

Set the range of the applied voltage to 0-10 V or 0-5 V. You cannot set it while outputting from the DC OUTPUT terminal.

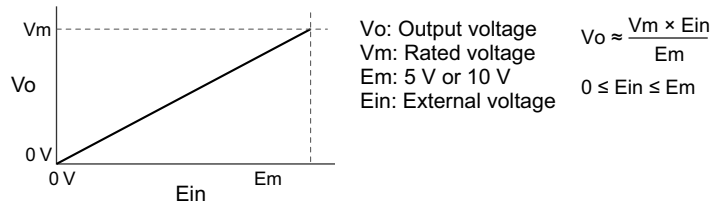

**1** Press System > EXT Config on the homepage.

**2** Press the input field for CV Range.

Each time you press the field, it switches between 0-10 V and 0-5 V.

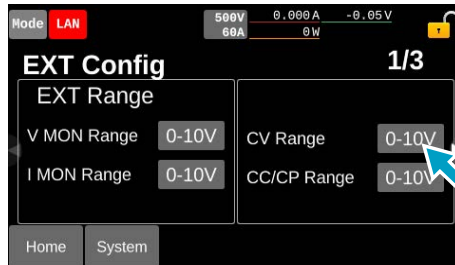

This completes the setting.

## Setting the input range of the current/power control signal

When an external voltage is applied to the analog input terminal (p.129), a current value or power value proportional to the change is obtained.

Set the range of the applied voltage to 0-10 V or 0-5 V. You cannot set it while outputting from the DC OUTPUT terminal.

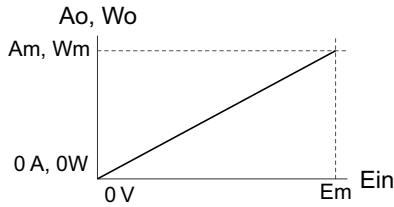

$A_o \cong \frac{A_m \times E_{in}}{E_m}$        $W_o \cong \frac{W_m \times E_{in}}{E_m}$   
 Ao: Output current      Am: Rated current       $0 \leq A_o \leq A_m$   
 Wo: Output power      Wm: Rated power       $0 \leq W_o \leq W_m$   
 Ein: External voltage       $0 \leq E_{in} \leq E_m$   
 Em: 5 V or 10 V

- 1 Press System > EXT Config on the homepage.
- 2 Press the input field for CC/CP Range.  
Each time you press the field, it switches between 0-10 V and 0-5 V.

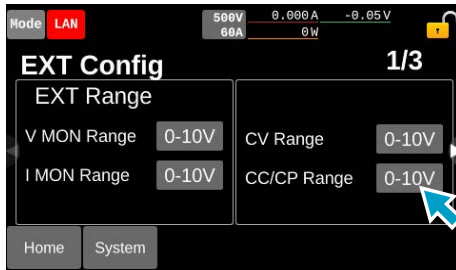

This completes the setting.

## Setting the output range of the voltage control signal

A signal with a voltage proportional to the output voltage value is output from the analog output terminal (p. 130).

Set the range of the output voltage to 0-10 V or 0-5 V. You cannot set it while outputting from the DC OUTPUT terminal.

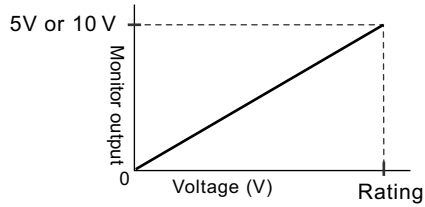

**1** Press **System > EXT Config** on the homepage.

**2** Press the input field for **V MON Range**.

Each time you press the field, it switches between 0-10 V and 0-5 V.

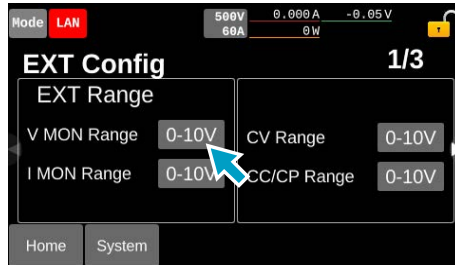

This completes the setting.

## Setting the output range of the current control signal

A signal with a voltage proportional to the output current value is output from the analog output terminal (p.130).

Set the range of the output voltage to 0-10 V or 0-5 V. You cannot set it while outputting from the DC OUTPUT terminal.

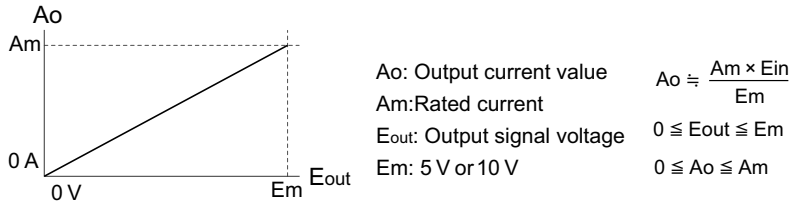

- 1 Press System > EXT Config on the homepage.
- 2 Press the input field for I MON Range.  
Each time you press the field, it switches between 0-10 V and 0-5 V.

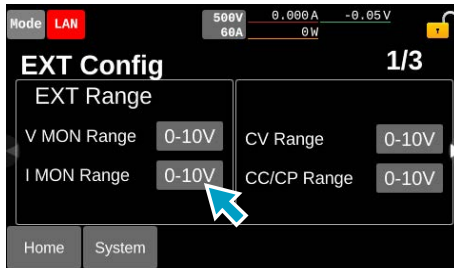

This completes the setting.

# Setting Digital Input/Output

Set the operation when a signal is entered to the digital input terminal (p.131) or digital output terminal (p.132) of EXT CONT.

## Enabling/disabling the digital input/output

When digital input/output is enabled, the EXT icon (  ) is displayed on the upper right of the screen.

**1** Press **System > EXT Config** on the homepage.

**2** Swipe to the left, or press the **▶** key.

**3** Press **DIGI Disable** or **DIGI Enable**.

Each time you press it, the digital input/output is switched to be enabled/disabled.

When digital input/output is enabled, the input fields for Ch. 1 to Ch. 6 are grayed out, and the functions cannot be switched.

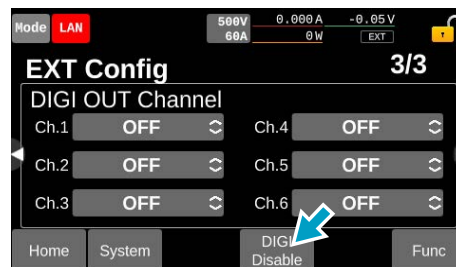

This completes the setting.

## Setting the functions of the general-purpose digital inputs

General-purpose digital input terminals are provided at Ch.1 to Ch.5. Ch.6 is fixed for H Alarm IN (HIGH alarm). Arbitrary functions from the following items can be selected respectively.

Set value	Description
OFF	Terminals are not used.
OUTPUT ON	When the signal is turned on from off, the output from the DC OUTPUT terminal is turned on.
OUTPUT OFF	While the signal is on, the output from the DC OUTPUT terminal is turned off.
OUTPUT CTRL	When the signal is turned on from off, the output from the DC OUTPUT terminal is turned on. While the signal is on, the output from the DC OUTPUT terminal is turned off.
L ALARM IN	While the signal is on, a LOW alarm is generated, and the output from the DC OUTPUT terminal is turned off.
ALARM CLR	When the signal is turned on from off, the LOW alarm will be cleared. If L ALARM IN is turned on simultaneously, L ALARM IN will be prioritized.
SEQ RUN	When the signal is set to ON from OFF, the sequence will be executed. When the signal is set to OFF from ON, the sequence will be canceled.
SEQ PAUSE	When the signal is set to ON from OFF, the sequence will be paused. When the signal is set to OFF from ON, the sequence will be resumed.
INTEG CTRL	When the signal is set to ON from OFF, the elapsed time, current, and power are integrated. When the signal is set to OFF from ON, integration stops.
INTEG RESET	While the signal setting is ON, the integrated values of elapsed time, current, and power are reset.
ACQUIRE TRIG	When the signal is set to ON from OFF, the measurement trigger will be input. When the Source of the measurement trigger is in the trigger wait state with EXT (p.49), the measurement will be started.
SEQ TRIG IN	When the signal is set to ON from OFF, the sequence trigger will be input. When the Wait Trig of the sequence is in the trigger wait state with EXT (p.109), the sequence will be started.
MEM1 RECALL	When the signal is set to ON from OFF, preset memory 1 will be recalled <sup>1</sup> .
MEM2 RECALL	When the signal is set to ON from OFF, preset memory 2 will be recalled <sup>1</sup> . If MEM1 RECALL is turned on simultaneously, MEM1 RECALL will be prioritized.
H ALARM IN	The function fixed to Ch.6. While the signal setting is ON, a HIGH alarm will be generated, and the output from the DC OUTPUT terminal is turned off.

1. While the signal is on, the set values to be saved in the preset memory cannot be changed.

- 1 Press System > EXT Config on the homepage.
- 2 Swipe to the left, or press the ► key.
- 3 When the input fields for Ch.1 to Ch.5 are grayed out, press DIGI Enable.

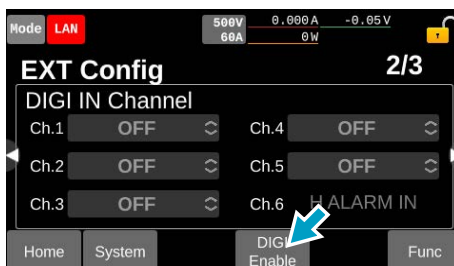

Disable the digital input/output.

**4** Press an arbitrary Ch.

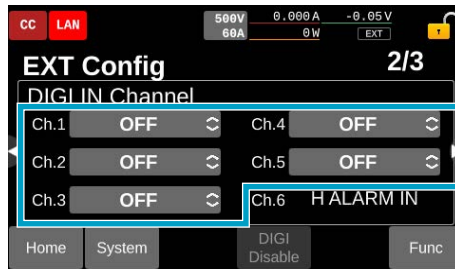

**5** Select and press the set value.  
This completes the setting.

**Priority relation between the general-purpose digital input and the front panel operation**

Priority relation between OUTPUT ON/OUTPUT OFF for general-purpose digital input and the OUTPUT key operation on the front panel is as shown below.

When the OUTPUT OFF signal is on, the OUTPUT OFF signal has priority over the OUTPUT ON signal and the OUTPUT key operation on the front panel.

When the OUTPUT OFF signal is off, the relation between the OUTPUT ON signal and the OUTPUT key operation is as follows.

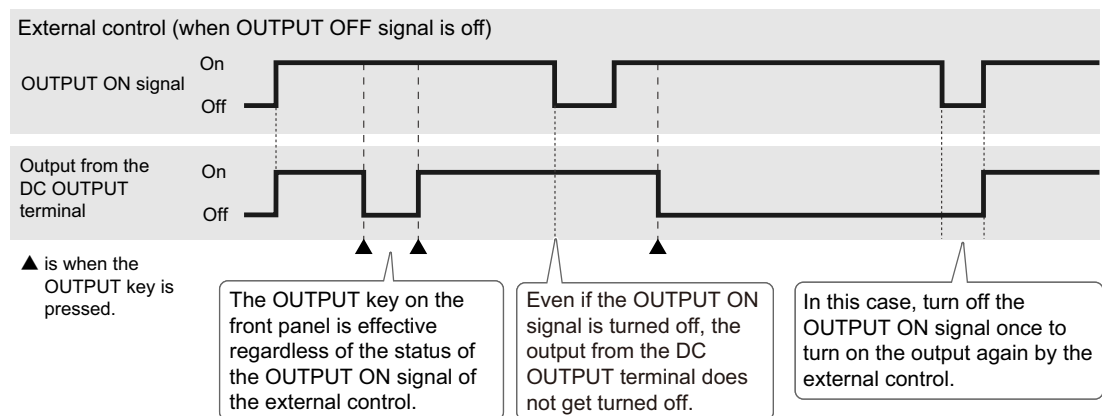

## Setting the functions of the general-purpose digital output

General-purpose digital output terminal are provided at Ch.1 to Ch.6. Arbitrary set values from the following items can be selected respectively.

Set value	Condition for outputting signals
OFF	Terminals are not used.
OUTPUT ON	The signal is turned on while outputting from the DC OUTPUT terminal.
POWER ON	The signal is turned on while outputting from the DC OUTPUT terminal is ready.
H ALARM OUT	The signal is turned on after a HIGH alarm is generated until it is cleared.
L ALARM OUT	The signal is turned on after a LOW alarm is generated until it is cleared.
CV STATUS	The signal is turned on while operating in the CC mode.
CC STATUS	The signal is turned on while operating in the CV mode.
SEQ TRIG OUT	Pulse signal is output when sequence step is started.
SEQ STATUS	The signal turns on while the steps of the sequence are running.
EXT DIN BUSY	The signal is turned on while the digital input of the EXT CONT connector is busy. When using both external control and remote control, monitor the EXT DIN BUSY signal. During the busy state, control not to input any signal to the digital input terminal.
MEM1 ACT TIME	When Preset Memory 1 is recalled by a general-purpose digital input, the signal is turned on until the set value is changed after the memory is recalled.
MEM2 ACT TIME	When Preset Memory 2 is recalled by a general-purpose digital input, the signal is turned on until the set value is changed after the memory is recalled.
RELAY DRIVE	The signal setting is set to on/off in step with on/off of the DC OUTPUT terminal output. The signal is output after approx. 100 ms from the output on/off.

### NOTE

When digital input/output is enabled by setting EXT DIN BUSY and a remote control is used, mind the following points.

- The remote control command processing will take more time than when EXT DIN BUSY is not set. For details, refer to “Main Command Processing Time” in the Interface Manual.
- Sending remote control commands at intervals shorter than 5 ms may stop the operation of PXT series.

- 1 Press System > EXT Config on the homepage.
- 2 Swipe to the left, or press the ► key, till DIGI OUT Channel is displayed.
- 3 When the input fields for Ch.1 to Ch.6 are grayed out, press DIGI Enable.

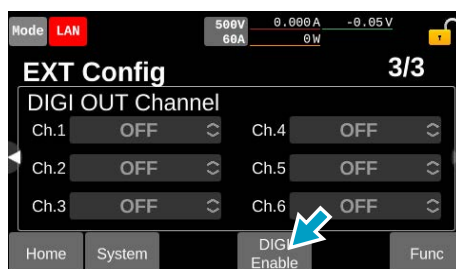

Disable the digital input/output.

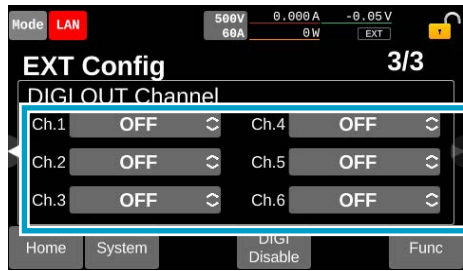
**4** Press an arbitrary Ch.**5** Select and press the set value.  
This completes the setting.

## Changing the filter for digital input

Set the signal input time filter for each digital input channel.

Set value	Behavior
SLOW	The digital input is activated when there is an input to the digital input terminal for 10 ms. This is recommended if you are using relays, etc. that may cause chattering.
FAST	The digital input is activated when there is an input to the digital input terminal for 150 $\mu$ s. This is recommended when using semiconductor switches, etc.

- 1 Press System > EXT Config on the homepage.
- 2 Swipe to the left, or press the ► key.
- 3 When the input fields for Ch.1 to Ch.5 are grayed out, press DIGI Enable.

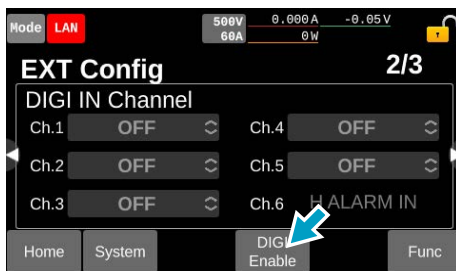

Disable the digital input/output.

- 4 Press Func.



“Func” switches to “Filter,” and the filter setup screen for each channel is displayed.

- 5 Select and press the set value for each channel.

Each time you press the button, it switches between SLOW and FAST.

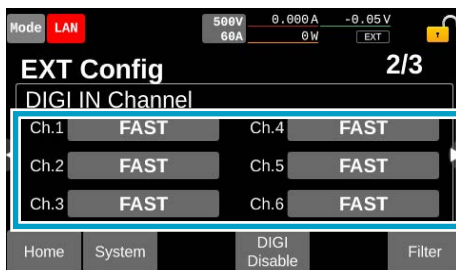

This completes the setting.

## Changing the polarities for digital input

Set the polarities of on/off for each digital input channel.

Set value	Behavior
Positive	It turns on when a current of 1.5 mA or more flows to the digital input channel.
Negative	It turns on when the current at the digital input channel drops to 0.1 mA or lower.

- 1 Press System > EXT Config on the homepage.
- 2 Swipe to the left, or press the ► key.
- 3 When the input fields for Ch.1 to Ch.5 are grayed out, press DIGI Enable.

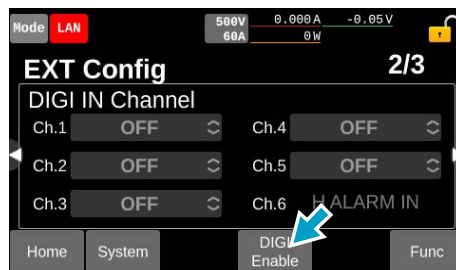

Disable the digital input/output.

- 4 Press Func > Filter.



It switches in the order of "Func" → "Filter" → "Polarity" to display the polarity setup screen for each channel.

- 5 Select and press the set value for each channel.

Each time you press the button, Positive and Negative are switched.

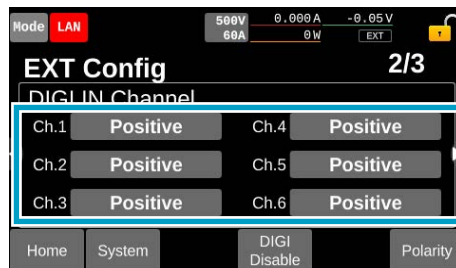

If the input field is grayed out, press DIGI Enable to enable the digital input/output. This completes the setting.

## Changing the polarities for digital output

Set the polarities of on/off for each digital output channel.

Set value	Behavior
Positive	When the digital output is on, the channel is closed.
Negative	When the digital output is on, the channel is open.

### NOTE

If the channel's general-purpose digital output function is set to POWER ON and the polarity is set to Negative, you cannot monitor whether outputting from the DC OUTPUT terminal is ready or not. This is because the channel is open before and after the power is turned on as well as when outputting is ready. In this case, the channel with POWER ON will be closed once when the power is turned off, and will be open again when the power is completely turned off.

- 1 Press System > EXT Config on the homepage.
- 2 Swipe to the left, or press the ► key, till DIGI OUT Channel is displayed.
- 3 When the input fields for Ch.1 to Ch.6 are grayed out, press DIGI Enable.

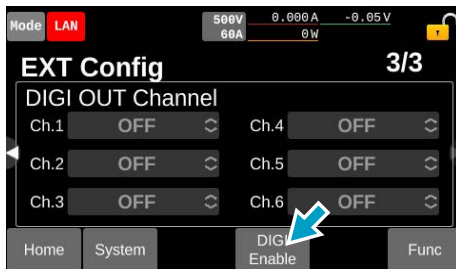

Disable the digital input/output.

- 4 Press Func.

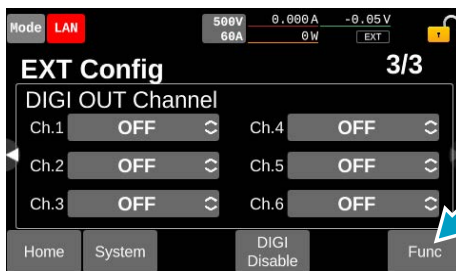

"Func" switches to "Polarity" to display the polarity setup screen for each channel.

## 5 Select and press the set value for each channel.

Each time you press the button, Positive and Negative are switched.

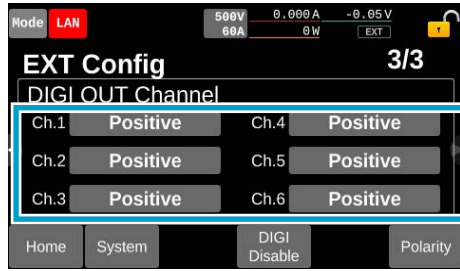

This completes the setting.

# System Settings

You can check/set the following items.

Item	Description
Communication	Set the operations related to LAN and RS232C connections ( <a href="#">p.149</a> )
VMCB Edit	Set Multichannel ( <a href="#">p.154</a> )
Model Info	Display information ( <a href="#">p.158</a> )
Key Lock Level	Set the key lock ( <a href="#">p.159</a> )
Sound/Display	Set the operations related to sound ( <a href="#">p.161</a> ) and display ( <a href="#">p.162</a> ).
Date Config	Set the year, month, day, and time ( <a href="#">p.163</a> )
Update	Update the firmware ( <a href="#">p.166</a> )
Factory Default	Return the product to its factory default condition ( <a href="#">p.167</a> )
SCPI Status	Check the details of SCPI errors ( <a href="#">p.170</a> )

# Communication Setting

Display and change of LAN settings, display and change of RS232C settings, and USB settings can be confirmed.

## Displaying LAN settings

When pressing System > Communication on the homepage or pressing the LAN icon in the upper left corner of the homepage, the LAN and network screen is displayed.

To display settings not fully displayed on the screen, swipe to the left or right, or press the ◀/▶ keys to scroll the page.

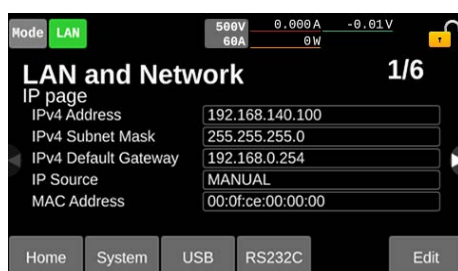

Following items can be confirmed.

Item	Description
IPv4 Address	IPv4 address
IPv4 Subnet Mask	IPv4 subnet mask
IPv4 Default Gateway	IPv4 default gateway
IP Source	IP address assignment method
MAC Address	MAC address
IPv4 DNS Server1	Primary IPv4 DNS server address
IPv4 DNS Server2	Secondary IPv4 DNS server address
Hostname	mDNS host name
Description	Description
Domain	Domain
VXI-11 VISA	VISA resource name of VXI-11
HiSLIP VISA	VISA resource name of HiSLIP
SCPI-RAW VISA	VISA resource name of SCPI-RAW
SCPI-RAW	Port number of SCPI-RAW
SCPI-Telnet	Port number of SCPI-Telnet
HiSLIP	Port number of HiSLIP

## Changing LAN settings

Following items can be changed. If you intend to use PXT series products in an existing network, check with your network administrator for configuration details.

Item	Description	Set value
IP Address assignment method	IP address assignment method	AUTO/MANUAL
IPv4 Address	IPv4 address	–
IPv4 Subnet Mask	IPv4 subnet mask	–
IPv4 Default Gateway	IPv4 default gateway	–
IPv4 DNS Server1	Primary IPv4 DNS server address	–
IPv4 DNS Server2	Secondary IPv4 DNS server address	–
Desired Hostname	Host name (15 characters maximum)	Factory default is model name and serial number.
Desired Description	Description (63 characters maximum)	Factory default setting: KIKUSUI <name> Regulated DC Power Supply -<serial> <name>: model name, <serial>: serial number
Dynamic DNS	Enabling/disabling of dynamic DNS	Enable/Disable
mDNS	Enabling/disabling of multicast DNS	Enable/Disable

### 1 Press System > Communication on the homepage.

LAN and network screens will be displayed.

The LAN setup screen is displayed also by pressing the LAN icon in the upper left corner of the homepage.

### 2 Press Edit.

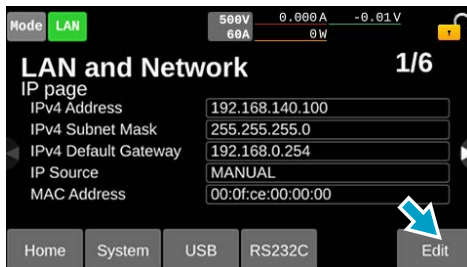

The communication setting edit screen is displayed.

### 3 Change values settings.

To display settings not fully displayed on the screen, swipe to the left or right, or press the ◀/▶ keys to scroll the page.

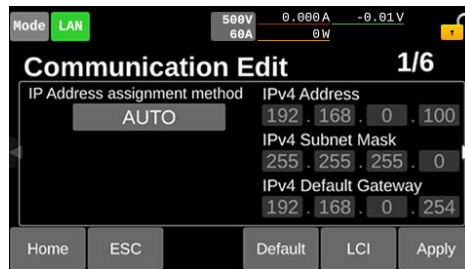

Press the input field to change the selected item, entered text/number, or the existence of checking according to the set item.

### 4 Press Apply.

A confirmation screen appears.

### 5 Press OK.

This completes the setting.

## Checking / changing the RS232C communication settings

Following items can be displayed/changed.

Item	Description	Set value
Data Bits	Data length	8 bit (fixed)
Parity	Parity	None (fixed)
Stop Bits	Stop bits	1 bit (fixed)
Bitrate	Baud rate [bps]	1200/2400/4800/9600/19200/38400/57600/115200
Flow Control	Flow control	None/CTS-RTS

### 1 Press System > Communication on the homepage.

LAN and network screens will be displayed.

The same screen will appear when you press the LAN icon in the upper left part on the homepage.

### 2 Press RS232C.

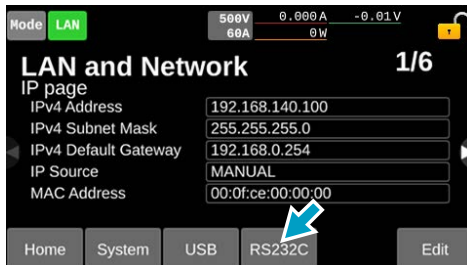

The RS232C setup screen is displayed.

### 3 Change values settings.

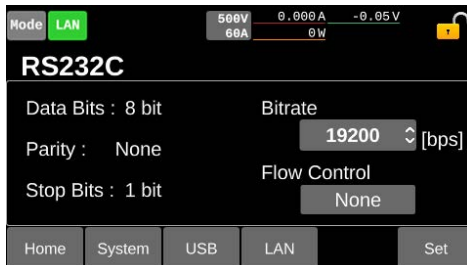

Press the input field to change settings.

### 4 Press Set.

A confirmation screen appears.

### 5 Press OK.

This completes the setting.

## Displaying USB settings

USB vendor ID and product ID are displayed.

### 1 Press System > Communication on the homepage.

LAN and network screens will be displayed.

The same screen will appear when you press the LAN icon in the upper left part on the homepage.

### 2 Press USB.



Vendor ID, Product ID, and Visa address are displayed.

# Setting Multichannel

## Multichannel

PXT series supports virtual multichannel (VMCB).

If you use Multichannel, you can connect one PC with up to 8 units of PXT series to construct a virtual multichannel power supply system. You can utilize this to reduce the number of communication ports and control the plural units of PXT series together.

To use Multichannel, connect a PC to PXT series with a switching hub or a broadband router. To control the connected PXT series, send a command from the PC to the PXT series. For details on the connection method and commands for controlling, refer to the Communication Interface Manual.

In this manual, explanations are made only for the Multichannel setting method that can be operated on the display.

## Set Multichannel

Set the VMCB Enable/Disable, master/slave units, domain number, and channel number.

Item	Description
VMCB Enable	Sets Enable/Disable of VMCB. If you use Multichannel, set this to Enable.
Master Unit	Sets VMCB master/slave units on PXT series connected to Multichannel. Via the PXT series unit set as the VMCB master unit, the PXT series units set as the VMCB slave units are controlled.
Domain Number	Sets the Domain number. PXT series that have the same domain number can be controlled under Multichannel as one VMCB network.
Channel	Sets the channel number for the PXT series set as the VMCB slave unit. Channel numbers are used to identify each VMCB slave unit when they are controlled from the PC using commands.

### 1 Press System > VMCB > Edit on the homepage.

Multichannel setup screen is displayed.

### 2 Set Enable/Disable of VMCB.

Press the check box of VMCB Enable.

Each time you press the check box, the existence of checking changes. With a check mark, it is enabled, without a check, it is disabled.

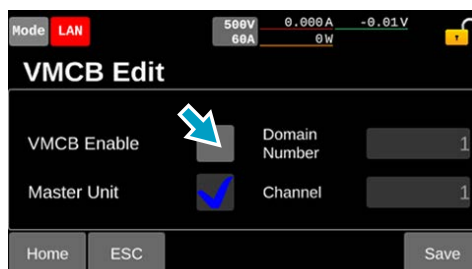

**3 Set VMCB master and slave units.**

**4 Press the check box of Master Unit.**

Each time you press the check box, the existence of checking changes. With the check, it is set as the VMCB master unit, without the check, it is set as a VMCB slave unit.



**5 Set the Domain number.**

**6 Press the input field for Domain Number and input the domain number on the display or with the rotary knob.**

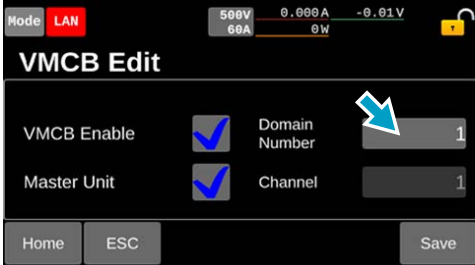

Setting range: 1 to 254

**7 When it is set as a VMCB slave unit in Step 3, set a channel number.**

Press the input field for Channel and input the channel number on the display or with the rotary knob. Setting of channel number is not necessary for the VMCB master unit.

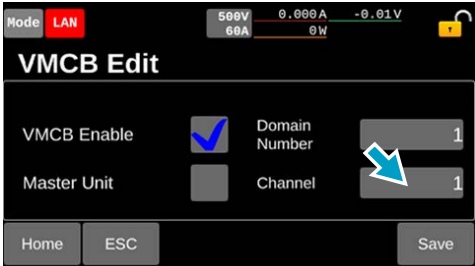

Setting range: 1 to 7

- 8 Press Save.**  
A confirmation screen appears.
- 9 Press OK.**  
Multichannel setup confirmation screen ([p. 157](#)) is displayed.
- 10 Turn the POWER switch off.**
- 11 Set all the units connected to Multichannel following Step 1 to Step 10.**  
For the connection method, refer to the Communication Interface Manual.
- 12 Turn the POWER switches ON in the order of VMCB slave unit to VMCB master unit, or turn the POWER switches of all units ON simultaneously. This completes the setting.**

# Check the settings of Multichannel

## 1 Press System > VMCB on the homepage.

Multichannel setup confirmation screen is displayed.  
Press Edit to display the Multichannel setup screen (p.154).

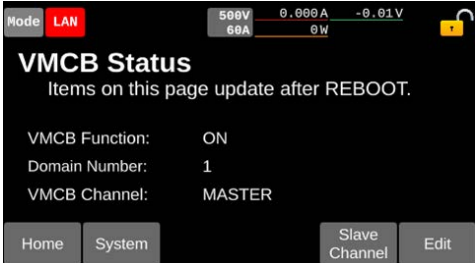

Item	Description
VMCB Function	Multichannel Enabled (ON) / Disabled (OFF)
Domain Number	Domain number
VMCB Channel	Channel number (For the VMCB master unit, "MASTER" is displayed.)

## 2 Press Slave Channel if it is the VMCB master unit.

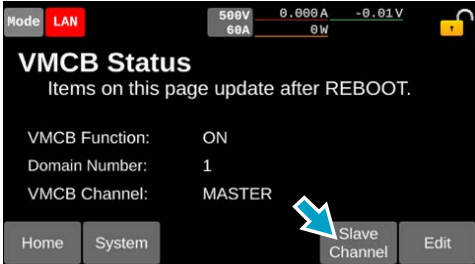

When a slave unit is detected, the channel list for the slave units is displayed.  
On the channel list, the channel number, model name, and output rating are displayed.

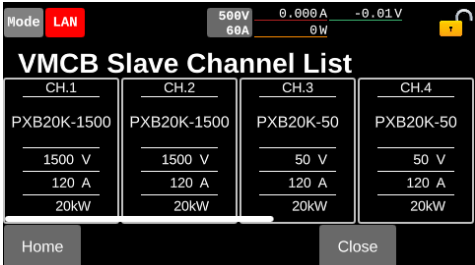

# Displaying the Device Information

You can display the model name, serial number, system version, and other device information.

## 1 Press **System > Model Info** on the homepage.

Model Name, Serial Number, System Version, PANEL Version, MAIN Version, FPGA Version, and AFE Version are displayed.

The same screen will be displayed by pressing the rated-value display on the upper part of the homepage.

To display settings not fully displayed on the screen, swipe to the left or right, or press the ◀▶ keys to scroll the page. Setup items are found on pages 1 through 2. The following figure shows an example of PXT20K-500.





# Key Lock

The keys can be locked to prevent changing the settings or overwriting memory by mistake.

## Setting key lock level

You can set three different key lock levels according to the type of keys whose operation is prohibited. While key lock is enabled, an icon is shown in the top area of the display depending on the key lock level.

Item	Allowed operations	Icon
Level1	Output ON/OFF, recall preset memory, and release key lock.	
Level2	Output ON/OFF and release key lock	
Level3	Output OFF and release key lock	

**1** Press System > Key Lock Level on the homepage.

**2** Press the input field for Key Lock Level.



**3** Select and press the item.

This completes the setting.

## Enabling or disabling the key lock

Key lock switches between enabled and disabled each time you press and hold the key lock icon.

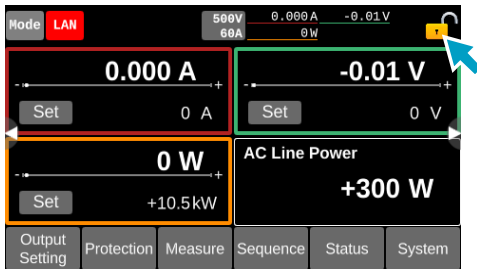

### If the key lock cannot be released

When the RWLS icon (🔒) or LWLS icon (🔒) are displayed, the key lock will not be canceled by pressing and holding. Turn off the power to the PXT series unit and turn it on again, or refer to the Communication Interface Manual to unlock the remote lock by command.

When the Remote key lock icon (🔒) is displayed, the key lock cannot be released by pressing and holding the icon if Web browser interface display and command transmission through a USB connection are performed simultaneously. Release the key lock by any of the following operations.

- Release the key lock remotely using a command
- Close the browser displaying the Web browser interface
- Disconnect the USB cable
- Turn the power supply of the PXT series off and then back on

For details on the command and Web browser interface, see the Communication Interface Manual.

# Buzzer Sound

You can enable or disable buzzer sounds that are emitted in case of invalid operation, alarm occurrence, or SCPI error.

## Enables or disables buzzer

- 1 Press **System** on the homepage.
- 2 Swipe to the left, or press the ► key.
- 3 Press **Sound/Display**.  
The screen for setting buzzer sound/display brightness is displayed.
- 4 Press the input field for **Protection, SCPI, or Key**.  
Each time you press the button, the existence of checking changes. If there is a check mark, a buzzer sound will be enabled.  
Protection: buzzer sound for alarm occurrence  
SCPI: buzzer sound for SCPI errors  
Key: buzzer sound for invalid operation



This completes the setting.

## Returning the buzzer to the factory default setting

By pressing **Default** on the screen for buzzer sound/display brightness settings, Buzzer and Brightness will return to the factory default settings.



# Screen Brightness

## Setting screen brightness

Set the screen brightness.

- 1** Press **System** on the homepage.
- 2** Swipe to the left, or press the ► key.
- 3** Press **Sound/Display**.  
The buzzer sound/display brightness setup screen is displayed.
- 4** Adjust the brightness by moving the **Brightness** slider.



This completes the setting.

## Returning the display brightness to the factory default setting

By pressing **Default** on the screen for buzzer sound/display brightness settings, Buzzer and Brightness will return to the factory default settings.



# Setting the Date/Time

Set the year, month, day, and time.

The factory default setting for the time zone is UTC+9 (Tokyo).

## Retrieving the time from an NTP server

- 1** Press **System** on the homepage.
- 2** Swipe to the left, or press the ► key, till **Date Config** is displayed.
- 3** Press **Date Config**.  
The date/time setup screen appears.  
Next, set the NTP server and time zone.

### Setting the NTP server

- 1** Press the input field for **NTP Server Hostname** on the date and time setup screen and input the NTP server address.

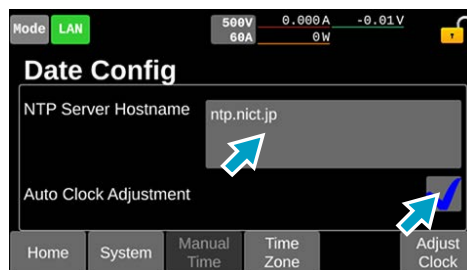

- 2** Press the input field for **Auto Clock Adjustment** and check the box.  
Each time pressing the button, the existence of checking changes.  
When checked, **Adjust Clock** is displayed on the menu. When **Adjust Clock** is pressed, information is immediately retrieved from the NTP server.  
This completes the setting.

## Setting the time zone

- 1 Press Time Zone on the date and time setup screen.



Time zone setup screen is displayed.



When pressing the region name, the city name corresponding to the region is displayed.

To display the region name not fully displayed on the screen, swipe the region name to the left, or press the ► key to scroll. To display city name not fully displayed on the screen, swipe the city name to the left, or scroll the screen with the rotary knob.

- 2 Press the region name and the city name.
- 3 Press Apply.  
This completes the setting.

## Setting the time manually

- 1 Press **System** on the homepage.
- 2 Swipe to the left, or press the ► key, till **Date Config** is displayed.
- 3 Press **Date Config**.  
The date/time setup screen appears.

- 4 Press **Manual Time**.

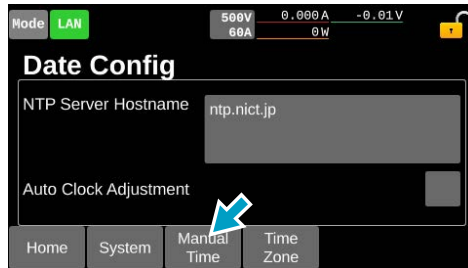

- 5 Set the year, month, day, and time.  
Press ↑ and ↓ to set the number.

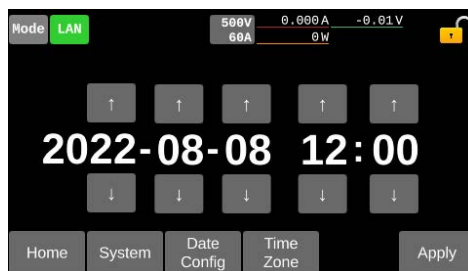

Setting range: 2022-1-1 0:00 to 2037-12-31 23:59

- 6 Press **Apply**.  
This completes the setting.

# Updating

You can update the product's firmware by using a USB memory device.

Updating is not available while an alarm is occurring or when the voltage coming from the DC OUTPUT terminal exceeds 30 V.

Updating is not available while an alarm is occurring or outputting from the DC OUTPUT terminal.

If there is an update, you can obtain it from the download service on the Kikusui website (<https://global.kikusui.co.jp/downloads/>).

## NOTE

Save the update files (Update.img, CHECKSUM.md5) in the root directory of the USB memory device. Do not change the names of the update files.

- 1 Press **System** on the homepage.
- 2 Swipe to the left, or press the ► key, till **Update** is displayed and press **Update**.  
An update screen appears.

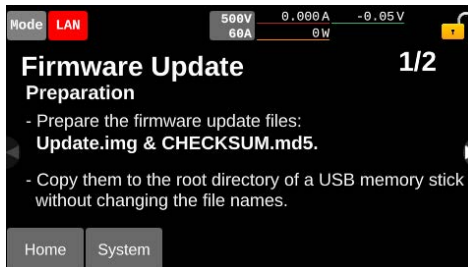

- 3 Swipe to the left, or press the ► key.
- 4 Insert the USB memory device on which the update files have been saved into the USB port on the front panel, and then press **Execute**.



A confirmation screen appears.

- 5 Press **OK > Enter**.  
The update process begins. Do not turn off the POWER switch while updating is in progress. Do not remove the USB memory device. When pressing the ESCAPE, updating is canceled and it restarts.
- 6 When “**Remove the USB media and turn the device off**” is displayed, remove the USB memory device.
- 7 Turn the **POWER** switch off, leave it for 10 seconds or more, then turn on power again.  
Updating is complete.

# Factory Default Settings and Reset Settings

As default settings, this product provides “factory default settings” and “reset settings” where parts of settings are returned to the factory default settings.

## Restoring the factory default settings

Restoring the factory default settings deletes all the user data.

For details on the factory default settings, refer to “Settings at Factory Default and at Reset” (p. 190).

- 1 Swipe to the right, or press the ◀ key on the homepage.
- 2 Press Memory.
- 3 Swipe to the left, or press the ▶ key and press Sanitize.
- 4 Press Initiate.

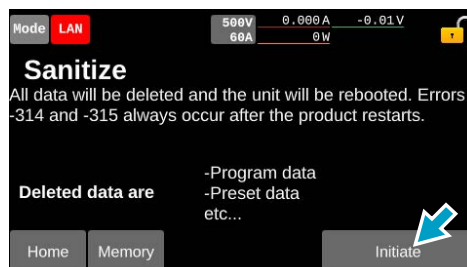

A confirmation screen appears.

- 5 Press OK.
- 6 When “Turn the power...” is displayed, turn off the POWER switch, and wait for 10 seconds or more before turning it on again.  
This will revert to the factory default setting.

### NOTE

After rebooting, the error messages of “-314 Save/recall memory lost” and “-315 Configuration memory lost” always appear, but they are not abnormal. To remove the error messages, press CLR on the SCPI error screen (p. 170) or turn the power off and then back on.

## Returning the LAN settings to the factory default values

Reset only the settings of LAN to the factory default settings.

For details on factory default setting, refer to “Settings at Factory Default and at Reset” (p.190).

**1** Press **System > Communication** on the homepage.

**2** Press **Edit > Default**.

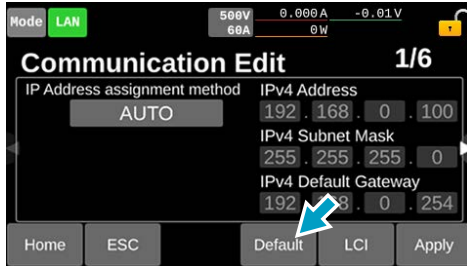

A confirmation screen appears.

**3** Press **OK**.  
The interface setting is reset.

## Resetting the LAN settings

Reset only the settings of LAN to the reset settings.

For details on reset setting, refer to “Settings at Factory Default and at Reset” (p.190).

**1** Press **System > Communication** on the homepage.

**2** Press **Edit > LCI**.

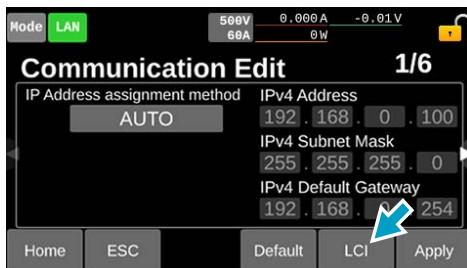

A confirmation screen appears.

**3** Press **OK**.  
The interface setting is reset.

## Restoring to reset settings

You can reset some of the settings to their factory defaults.

For the items to be reset, refer to “Settings at Factory Default and at Reset” (p. 190).

### NOTE

When Output OFF Delay (p. 75) is set at other than zero second, if you reset the settings while the output is on, the output shall be turned off at the elapsed time set by Output OFF Delay and the setting returns to reset.

### Resetting at power-on

The settings return to the reset settings each time at startup.

- 1 Swipe to the right, or press the ◀ key on the homepage.
- 2 Press Memory > Memory Config.
- 3 Press the input field for Power ON Settings.

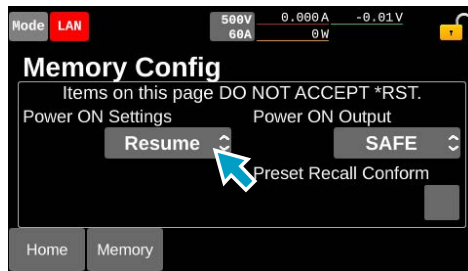

- 4 Press RST.
- 5 Turn the POWER switch off, leave it for 10 seconds or more, then turn on power again.  
It will start in a reset state.

### Resetting immediately

- 1 Swipe to the right, or press the ◀ key on the homepage.
- 2 Press Memory > \*RST on the homepage.

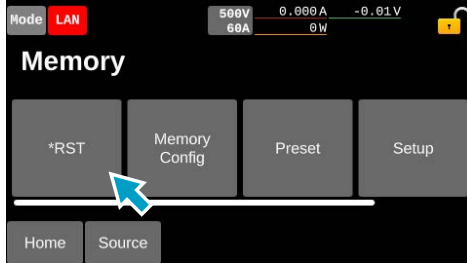

A confirmation screen appears.

- 3 Press OK.  
Settings are reset.

## Displaying SCPI Errors

You can check the content of the SCPI error when an SCPI error occurs during remote control. Up to 16 errors are displayed. If the 17th error occurs, the 16th error changes to “-350 Queue overflow,” and subsequent errors are not displayed.

- 1 Press Status > SCPI Status on the homepage.  
The SCPI error number is displayed.  
The same screen will appear when you press the SCPI error information on the upper part of the homepage.
- 2 Press the error number.

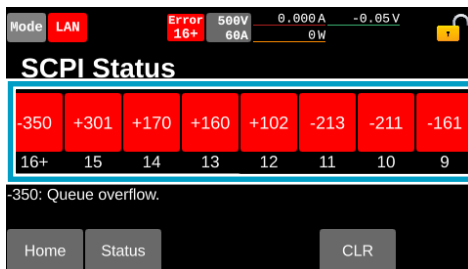

The details of the error will be displayed under the error number. The details of the error will be displayed. For details on errors, see the Communication Interface Manual on the included CD-ROM.

When CLR is pressed or the power supply to this product is turned on again after the cause of the error is removed, the error is deleted.

## Cleaning the Dust Filter

### **⚠ WARNING**

**Risk of electric shock.**

- Turn the **POWER switch off**, and turn the switch of the switchboard off.

This product has 3 louvers and 5 dust filters. Dust filters are set inside of each louver and the front panel respectively. Remove the louvers and take out the dust filters for cleaning. Clean the dust filters regularly to prevent them from clogging.

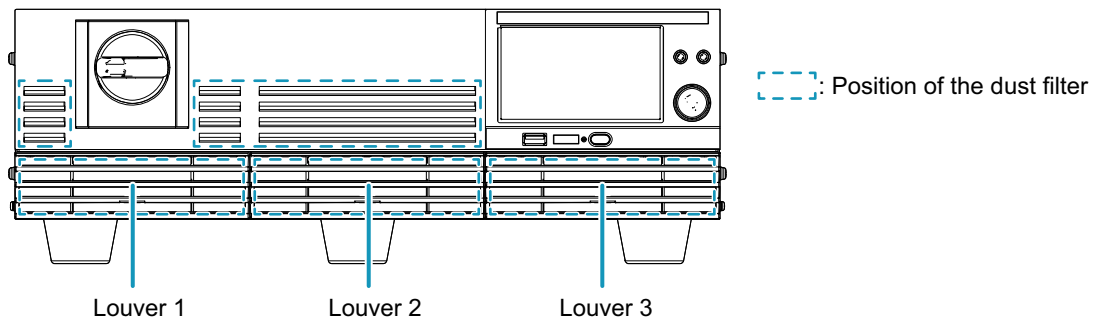

### **NOTE**

Clogging may lead to malfunction or the reduction of the product's service life.

- If the dust filter is clogged, the product's internal cooling capabilities will be reduced.
- When PXT series is in operation, air is sucked through the dust filter to cool the inside of the device. If moisture is present in the dust filter, the temperature or humidity inside PXT series increases.

## Removing the dust filter

- 1 Remove a louver 1 by pushing up the center part of the second rung from the bottom and pulling it toward you.

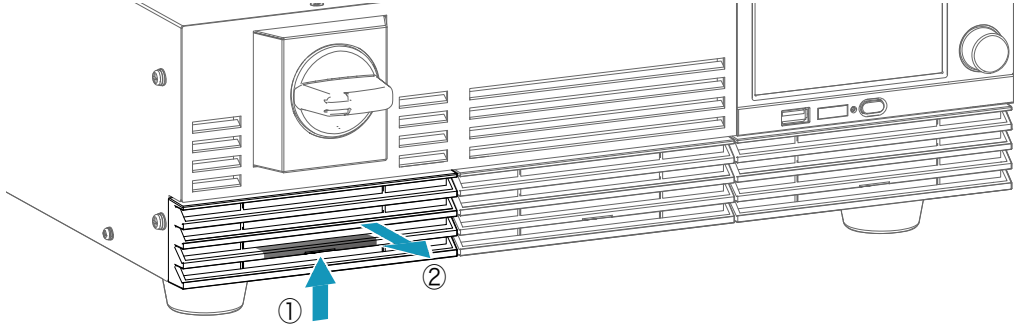

- 2 Remove the louvers 2 and 3 in the same way.
- 3 Remove the dust filters set inside the louvers.

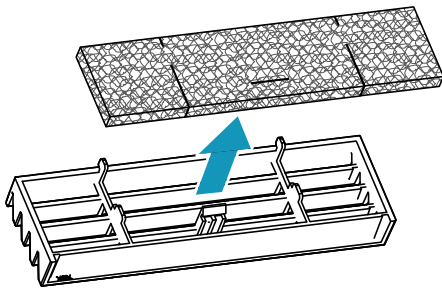

- 4 Remove the dust filters set inside the front panel. Pull it down from the bottom to take out. Use some tweezers or the like as necessary.

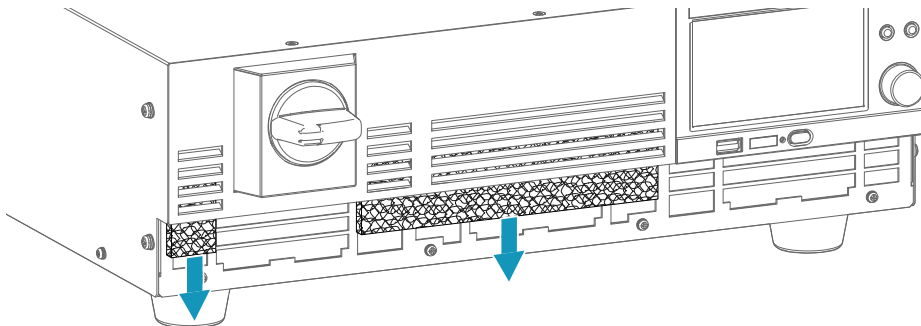

This completes the removal.

## Cleaning the dust filter

Use a vacuum cleaner to dispose of the dust and foreign particles that are attached to the dust filters. If the filter is extremely dirty, clean it using water-diluted neutral detergent, and dry it completely.

# Attaching the dust filter

**1** Insert the dust filters inside the front panel.

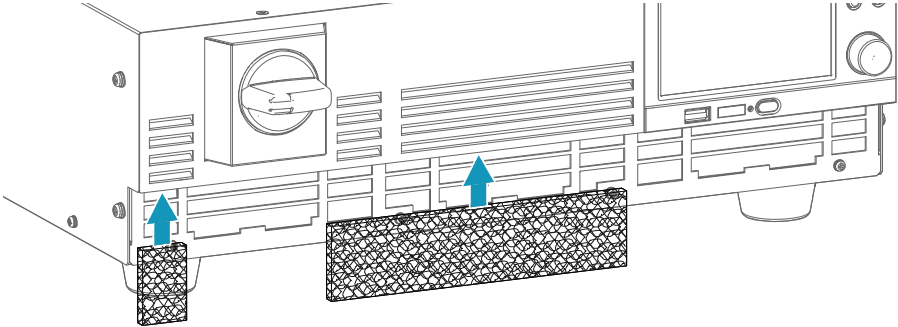

**2** Attach the dust filters to the inside of the louver. Attach the dust filters so that the louver's tabs pass through the cuts in the dust filter.

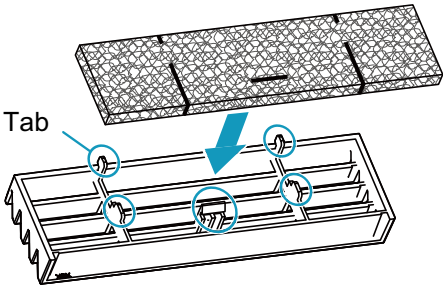

**3** Attach the louver 1 to the front panel. Insert the claws on the upper part of the louver first, and then install it.

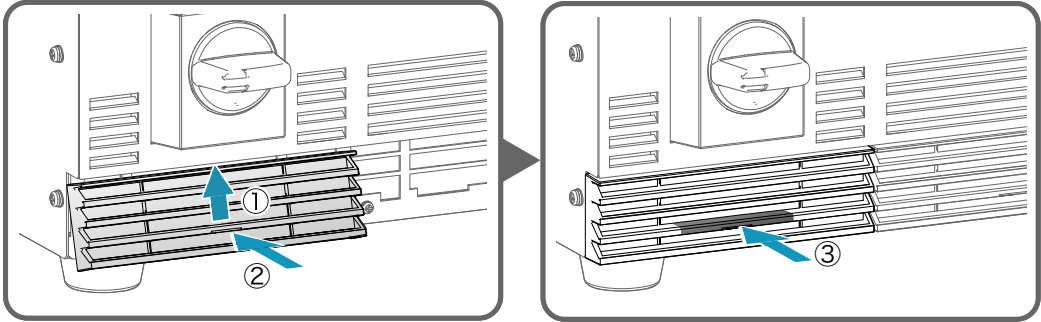

**4** Install the louvers 2 and 3 in the same way. This completes the installation.

# Inspection

To purchase accessories or options, contact your Kikusui agent or distributor.

## Periodic inspections

Although ideal inspection frequency varies depending on usage patterns, we recommend having the product inspected by your Kikusui agent or distributor every 10000 operating hours.

## Backup battery replacement

The product has a battery inside. The battery's service life differs depending on the environment that the product is used in, but three years after it is purchased is a rough estimate for the battery's service life. When the battery is exhausted, the time becomes inaccurate. For information about replacing the battery, contact your Kikusui agent or distributor.

## Calibration

The product is calibrated before shipment. To maintain the product's performance, we recommend periodic calibration. To have your product calibrated, contact your Kikusui agent or distributor.

# Disposal

Dispose of PXT series in accordance with your local regulations.

## Removing the battery at the time of disposal

This product contains a CR2032 coin-type manganese dioxide lithium battery.

Dispose of the product in accordance with your local regulations after removing the battery referring to the followings.

### **⚠ WARNING**

**Risk of electric shock.**

- To remove the power cord from the switchboard, turn the switch of the switchboard off.

**Risk of rupture or ignition.**

- Do not short-circuit, charge, disassemble, deform, throw into fire, or overheat the built-in battery.

### **NOTE**

The warranty does not apply if the top cover is opened.

### **1** Remove the screws holding the top cover.

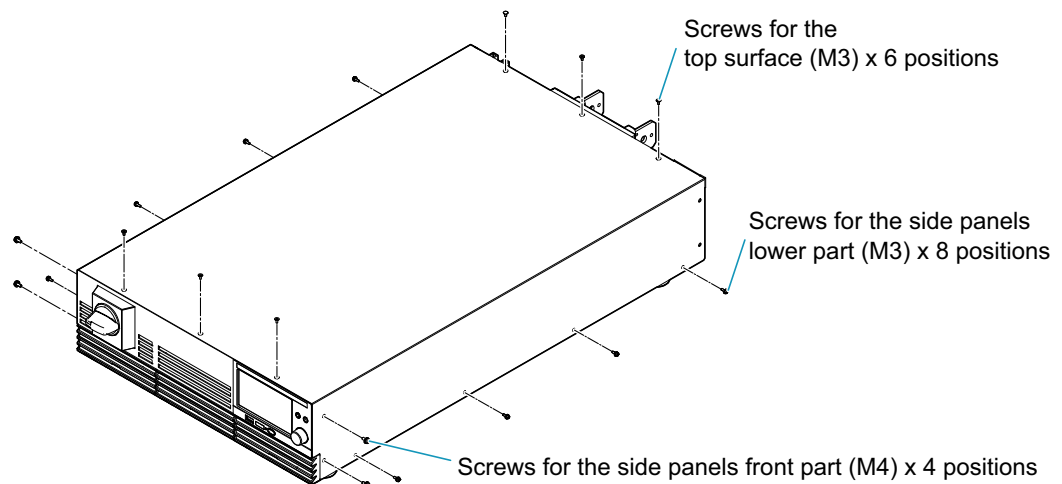

**2** Remove the cover.

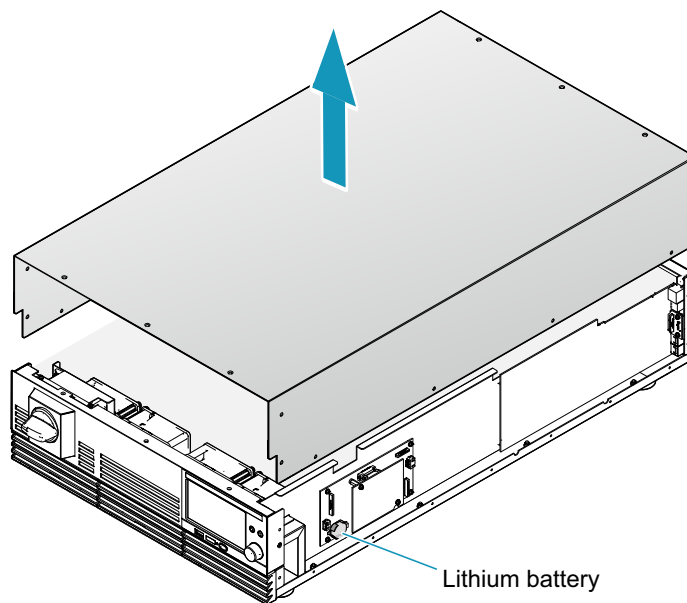

**3** Remove the lithium battery.

After removing the battery, completely cover their electrode parts with insulation tape.

**4** Close the cover and fasten the screws.

This completes the removal of the battery.

# Specifications

Unless specified otherwise, the specifications are for the following settings and conditions.

- The product is warmed up for at least 30 minutes.

The used terminology is as follows:

- TYP: These are typical values that are representative of situations where the product operates in an environment with an ambient temperature of 23 °C (73.4 °F). These values do not guarantee the performance of this product.
- setting: Indicates a setting.
- reading: Indicates a readout value.
- rating: Indicates a rated value.
- Open: Indicates equivalence to the state in which the DC OUTPUT terminals are opened.
- Vout: Indicates an output voltage.

## Output Specifications

### Output rating

Item	PXT20K-500	PXT20K-1000	PXT20K-1500
Rated power	20000 W	20000 W	20000 W
Rated voltage <sup>1</sup>	0 V to 500 V	0 V to 1000 V	0 V to 1500 V
Rated current <sup>1</sup>	120 A	60 A	30 A

1. Limited by the maximum output power.

## Output voltage

Item	PXT20K-500	PXT20K-1000	PXT20K-1500	
Maximum settable voltage	525 V	1050 V	1575 V	
Setting accuracy	$\pm(0.2\% \text{ of setting} + 0.1\% \text{ of rating})$			
Setting resolution	0.05 V	0.1 V	0.1 V	
Power fluctuation <sup>1</sup>	$\pm 100 \text{ mV}$	$\pm 200 \text{ mV}$	$\pm 300 \text{ mV}$	
Load variation <sup>2</sup>	$\pm 250 \text{ mV}$	$\pm 750 \text{ mV}$	$\pm 750 \text{ mV}$	
Remote sensing Maximum compensation voltage (recip- rocating) (TYP)	10 % of rating	10 % of rating	10 % of rating	
Internal resistance setting upper limit	5250 m $\Omega$	21000 m $\Omega$	63000 m $\Omega$	
Internal resistance setting resolution	1 m $\Omega$	2 m $\Omega$	5 m $\Omega$	
Response switching	FAST, SLOW	FAST, SLOW	FAST, SLOW	
Slew rate switching	25 V/ms	50 V/ms	75 V/ms	
	12.5 V/ms	25.0 V/ms	37.5 V/ms	
	1.25 V/ms	2.50 V/ms	3.75 V/ms	
	0.125 V/ms	0.250 V/ms	0.375 V/ms	
Slew rate setting accuracy	$\pm(20\% \text{ of setting} + 2.5 \text{ ms})$			
Transient response <sup>3</sup>	6 ms or less	6 ms or less	6 ms or less	
Ripple noise <sup>4</sup>	p-p <sup>5</sup>	700 mV	1500 mV	1750 mV
	rms <sup>6</sup>	100 mV	250 mV	300 mV
Rise time <sup>7</sup>	Full load <sup>8</sup>	25 ms	25 ms	25 ms
	No load	25 ms	25 ms	25 ms
Fall time <sup>9</sup>	Full load <sup>8</sup>	25 ms	25 ms	25 ms
	No load	750 ms	750 ms	750 ms

- 180 Vac to 252 Vac for 200 Vac input, 342 Vac to 504 Vac for 400 Vac input. At the constant load.
- The amount of change that occurs when the load is changed from no load to full load (rated output power/rated output voltage) with rated output voltage. The value is measured at the sensing point.
- The amount of time required for the output voltage to return to a value within the rated output voltage  $\pm(0.1\% + 10 \text{ mV})$  when the response setting of the CV mode is FAST. The load current fluctuation is 50 % to 100 % of the maximum current with the set output voltage.
- In the case where the CV mode response setting is FAST and having the rated output current. Values measured using JEITA RC-9131C probe and 100:1 probe.
- Measurement frequency band: 10 Hz to 20 MHz
- Measurement frequency band: 10 Hz to 1 MHz
- Applicable to the case where the CV mode response setting is FAST and the rated output voltage changes from 10 % to 90 %.
- For a pure resistance.
- Applicable to the case where the CV mode response setting is FAST and the rated output voltage changes from 90 % to 10 %.

## Output current

Item	PXT20K-500	PXT20K-1000	PXT20K-1500
Maximum settable current <sup>1</sup>	126 A	63 A	31.5 A
Setting accuracy	±(0.75 % of rating)	±(0.75 % of rating)	±(0.75 % of rating)
Setting resolution	0.01 A	0.005 A	0.002 A
Power fluctuation	±240 mA	±120 mA	±60 mA
Load variation	±240 mA	±120 mA	±60 mA
Rise time (Short-circuit) (TYP) <sup>2</sup>	25 ms	25 ms	25 ms
Fall time (Short-circuit) (TYP) <sup>3</sup>	25 ms	25 ms	25 ms
Response switching	FAST, SLOW	FAST, SLOW	FAST, SLOW
Slew rate switching <sup>1</sup>	6 A/ms	3 A/ms	1.5 A/ms
	3 A/ms	1.5 A/ms	0.75 A/ms
	0.3 A/ms	0.15 A/ms	0.075 A/ms
	0.03 A/ms	0.015 A/ms	0.0075 A/ms
Slew rate setting accuracy	±(20 % of setting +2.5 ms)	±(20 % of setting +2.5 ms)	±(20 % of setting +2.5 ms)

1. During parallel operation, this will be the value multiplied by the number of units in the configuration.
2. In the case that the CC mode response setting is set to FAST and the slew rate setting is set to the fastest: Applied in response to changes from 10 % to 90 % of rated output current.
3. In the case that the CC mode response setting is set to FAST and the slew rate setting is set to the fastest: Applied in response to changes from 90 % to 10 % of rated output current.

## Output power

Item	Common to all models
Maximum settable power <sup>1</sup>	21000 W
Setting accuracy <sup>2</sup>	±(0.5 % of power rating + 0.5 % of current rating × Vout)
Setting resolution	2 W

1. During parallel operation, this will be the value multiplied by the number of units in the configuration.
2. Equal to or higher than 5 % of the rated power is guaranteed. Less than 5 % of the rated power is guaranteed as a TYP value.

# Input Specifications

## 200 V three-phase three-wire input

Specifications for models having an input voltage rating of 200 Vac.

Item	Common to all models
Nominal input rating	200 Vac to 240 Vac, 50 Hz to 60 Hz
Input voltage range	180 Vac to 252 Vac
Input frequency range	47 Hz to 63 Hz
Input current (MAX) <sup>1</sup>	80 A (When Input voltage is 180 V)
Input power (MAX) <sup>1</sup>	24 kVA
Inrush current (TYP) <sup>2</sup>	90 A
Power factor (TYP) <sup>1</sup>	0.96
Output hold time	10 ms or more

1. At the rated output power for the rated output current.
2. Maximum peak current value when the POWER switch is turned on. (Excluding the surge current to the input filter capacitor.)

## 400 V three-phase three-wire input

Specifications for models having an input voltage rating of 400 Vac.

Item	Common to all models
Nominal input rating	380 Vac to 480 Vac, 50 Hz to 60 Hz
Input voltage range	342 Vac to 504 Vac
Input frequency range	47 Hz to 63 Hz
Input current (MAX) <sup>1</sup>	40 A (When Input voltage is 342 V)
Input power (MAX) <sup>1</sup>	24 kVA
Inrush current (TYP) <sup>2</sup>	70 A
Power factor (TYP) <sup>1</sup>	0.96
Output hold time	10 ms or more

1. At the rated output power for the rated output current.
2. Maximum peak current value when the POWER switch is turned on. (Excluding the surge current to the input filter capacitor.)

# Display Specifications

Item		PXT20K-500	PXT20K-1000	PXT20K-1500
Voltmeter	Maximum display	±600.00 V	±1200.00 V	±1800.00 V
	Display accuracy	±(0.1 % of reading + 0.2 % of rating)		
Ammeter	Maximum display	±168.000 A	±84.000 A	±42.000 A
	Display accuracy	±(0.75 % of rating)	±(0.75 % of rating)	±(0.75 % of rating)
Wattmeter	Maximum display <sup>1</sup>	±24.000 kW	±24.000 kW	±24.000 kW
	Display accuracy	Display the integrated value of voltmeter and ammeter		
Operation display	Output ON / OFF	The OUTPUT LED on the front panel lights in green		
	Operation mode	Indicate the followings on the upper left part of the display CV: Green CV icon CC: Red CC icon CP: Orange CP icon		
	Remote (LAN)	Indicate the followings on the upper left part of the display Not connected: Red LAN icon Preparing for connection: Orange LAN icon Connected: Green LAN icon		
	Alarm	Indicate the details of activated protection function on the display		
	SCPI error	Indicate the error occurring at present on the display		
	POWER off	Indicate residual charge warning and an instruction to turn off the display, then reboot		
	Key lock	Indicate the key lock status on the upper right part of the display		
	Sensing	When sensing is enabled, indicate the sensing icon on the upper right part of the display		
	During parallel operation	Displaying the slave state on the slave unit		
	External control	When digital input/output is enabled, indicate the EXT icon on the upper right part of the display		
	While a sequence is running	Indicate the RUN icon on the upper right part of the display		
	Synchronization state	Indicate the Sync icon on the upper right part of the display		
	Output delayed	Indicate a yellow mark on the upper left part of the display		

1. The unit will be W if it is less than 10 kW.

# Protection Specifications

## LOW alarm

An alarm not requiring a reboot to be cleared.

Item		PXT20K-500	PXT20K-1000	PXT20K-1500
OVP (overvoltage protection)	Protection operation	Output off, indicate "OVP" on the display. SLV OVP is displayed on the slave unit.		
	Setting range	50 V to 550 V	100 V to 1100 V	150 V to 1650 V
	Setting accuracy	$\pm(0.1\% \text{ of setting} + 0.2\% \text{ of rating})$		
	Setting resolution	0.05 V	0.1 V	0.1 V
OCP (overcurrent protection)	Protection operation	Output off, indicate "OCP" on the display. SLV OCP is displayed on the slave unit.		
	Setting range <sup>1</sup>	12 A to 132 A	6 A to 66 A	3 A to 33 A
	Setting accuracy	$\pm(0.75\% \text{ of rating})$	$\pm(0.75\% \text{ of rating})$	$\pm(0.75\% \text{ of rating})$
	Setting resolution	0.01 A	0.005 A	0.002 A
OPP (overpower protection)	Protection operation	Output off, indicate "OPP" on the display. SLV OPP is displayed on the slave unit.		
	Setting range <sup>1</sup>	2 kW to 24 kW	2 kW to 24 kW	2 kW to 24 kW
	Setting accuracy	$\pm(1.0\% \text{ of power rating} + 1.0\% \text{ of current rating} \times V_{out})$		
	Setting resolution	2 W	2 W	2 W
UVP (undervoltage protection)	Protection operation	Output off, indicate "UVP" on the display. SLV UVP is displayed on the slave unit.		
	Setting range	0 V to 500 V	0 V to 1000 V	0 V to 1500 V
	Selectable	Enable/Disable	Enable/Disable	Enable/Disable
	Setting accuracy	$\pm(0.1\% \text{ of setting} + 0.2\% \text{ of rating})$		
	Setting resolution	0.05 V	0.1 V	0.1 V
Watchdog Alarm (Communication error protection)	Protection operation	Output off, indicate "WDOG" on the display		
	Setting range	1 s to 3600 s	1 s to 3600 s	1 s to 3600 s
	Selectable	Enable/Disable	Enable/Disable	Enable/Disable
External Alarm LOW Level (external input alarm detection)	Protection operation	Output off, indicate "EXT LOW" on the display		

1. During parallel operation, this will be the value multiplied by the number of units in the configuration.

## HIGH alarm

An alarm requiring a reboot to be cleared.

Item		Common to all models
Reverse Alarm (Reverse-connection detection protection)	Protection operation	Output off, indicate "REVE" on the display
OHP (Overheat protection)	Protection operation	Output off, indicate "OHP" on the display. SLV OHP is displayed on the slave unit.
Line OVP (Grid overvoltage protection)	Protection operation	Output off, indicate "LOVP" on the display. SLV LOVP is displayed on the slave unit.
	Setting range	Input voltage rating 200 Vac model: 200 V to 258 V Input voltage rating 400 Vac model: 380 V to 516 V
Line UVP (Grid undervoltage protection)	Protection operation	Output off, indicate "LUVP" on the display. SLV LUVP is displayed on the slave unit.
	Setting range	Input voltage rating 200 Vac model: 175 V or less. Input voltage rating 400 Vac model: 333 V or less.
Line Frequency Error (Grid abnormal frequency protection)	Protection operation	Output off, indicate "FREQ" on the display. SLV FREQ is displayed on the slave unit.
	Detection value	42 Hz/68 Hz
External Alarm HIGH Level (External input alarm detection)	Protection operation	Output off, indicate "EXT HIGH" on the display
Parallel Communication Error (Parallel operation communication error detected)	Protection operation	Output off, indicate "PARA COM" on the display
Para Other Slave Alarm (Parallel operation slave error occurred)	Protection operation	Output off, indicate "SLV OTHR" on the display
Incorrect Slave Alarm (Not applicable device connected)	Protection operation	Output off, indicate "SLV INC" on the display
Too many connections (Too many parallel connections)	Protection operation	Output off, indicate "TOO MANY" on the display
Hardware ERR <sup>1</sup> (Hardware error)	Protection operation	Output off, indicate "ERRH" on the display. SLV ERRH is displayed on the slave unit.
Software ERR <sup>2</sup> (Software error)	Protection operation	Output off, indicate "ERRS" on the display. SLV ERRS is displayed on the slave unit.

1. It occurs when an abnormality related to the hardware is detected and the internal unit comes to an emergency stop.
2. It occurs when an abnormality related to the software is detected and the internal unit comes to an emergency stop.

# External Control Specifications

## External analog I/O

Item		Specifications	
Input	Input points	2 points	
	Voltage (CV) external voltage control	Setting range	0 % to 100 % of the rated output voltage
		Input voltage range	0 V to +5 V or 0 V to +10 V (Selectable)
		Accuracy	±(1 % of rating)
	Current (CC) external voltage control, power (CP) external voltage control <sup>1</sup>	Setting range	0 % to 100 % of the rated current and rated power
		Input voltage range	0 V to +5 V or 0 V to +10 V (Selectable)
Accuracy		±(1 % of rating)	
Output	Output points	2 points	
	Voltage monitor (VMON) Current monitor (IMON)	Output range	0 % to 100 % of the rated output voltage
		Output voltage	0 V to 5 V or 0 V to 10 V (Selectable)
		Accuracy	±(1 % of rating)

1. Select either current control or power control.

## External digital input

Item		Specifications
Fixed input points		1 point (Polarity switchable)
Selected input points		5 points (Polarity switchable)
Input form		Photocoupler isolated input (Applicable to both current sink / source output)
Fixed function	ALARM IN	HIGH alarm occurrence
Selecting function	OFF	Do not use terminals
	OUTPUT ON	Turn on the output
	OUTPUT OFF	Turn off the output
	OUTPUT CTRL	Turn on of off the output
	L ALARM IN	LOW alarm occurrence
	ALARM CLR	LOW alarm clearance
	SEQ RUN	Sequence start/end
	SEQ PAUSE	Sequence pause/resume
	SEQ TRIG IN	Input the trigger for sequence
	ACQUIRE TRIG	Input the measurement trigger
	MEM1 RECALL	Recall preset memory 1
	MEM2 RECALL	Recall preset memory 2
	INTEG CTRL	Starting/stopping integration measurement
INTEG RESET	Resetting integration measurement data	
External circuit power supply range		12 V to 24 Vdc (±10 %)

## External digital output

Item	Specifications	
Output points	6 points (Polarity switchable)	
Output form	Semiconductor relay output	
Selecting function	OFF	Do not use terminals
	OUTPUT ON	Outputting the signal while the output is ON
	POWER ON	Signal is output when power supply is on and output is possible
	H ALARM OUT	Output a signal when a HIGH alarm occurs
	L ALARM OUT	Output a signal when a LOW alarm occurs
	CC STATUS	Output a signal when operating in the CC mode
	CV STATUS	Output a signal when operating in the CV mode
	SEQ TRIG OUT	Output the trigger for sequence
	SEQ STATUS	Signal is output while the sequence is running
	EXT DIN BUSY	Output a signal when the digital input is in BUSY status
	MEM1 ACT TIME	Signal is output when the setting is completed for preset memory 1
	MEM2 ACT TIME	Signal is output when the setting is completed for preset memory 2
	RELAY DRIVE	Output a signal after approx. 100 ms in step with on/off of the DC OUTPUT terminal output. You can set this parameter to only Ch.6.

# Communication Specifications

Item		Specifications
Common specifications	Software protocol	IEEE std. 488.2-1992
	Command language	Complies with SCPI Specification 1999.0
RS232C	Hardware	D-SUB 9-pin connector Baud rate: 1200, 2400, 4800, 9600, 19200, 38400, 57600, 115200 bps Data length: 8 bits, Stop bits: 1 bit, Parity bit: None Flow control: No, CTS-RTS
	Program message terminator	LF during reception, LF during transmission
USB (device)	Hardware	Standard type B socket Complies with the USB 2.0 specifications; data rate: 480 Mbps (high speed)
	Program message terminator	LF or EOM during reception, LF + EOM during transmission
	Device class	Complies with the USBTMC-USB488 device class specifications
USB (host)	Hardware	Standard type A socket Complies with the USB 2.0 specifications; data rate: 480 Mbps (high speed)
LAN	Hardware	IEEE 802.3 100BASE-TX or 10BASE-T Ethernet
	Communication protocol	SCPI-RAW, SCPI-Telnet, HiSLIP, VXI-11
	Program message terminator	SCPI-RAW: LF during reception, LF during transmission HiSLIP: LF or END during reception, LF + END during transmission.
	Compliant standards	LXI Version 1.5 Specifications 2016

## Others

Item		Specifications	
Synchronization function (clock synchronization)	Overview	SYNC icon is displayed on the display when synchronization is established with the internal clock after connecting with other PXT series using the EXT SYNC connector.	
	Sequence synchronization	Synchronization of the program start and step start.	
	Measurement synchronization	Synchronization of the measurement start	
	Output synchronization	Synchronization of output ON/OFF	
Sequence function	Operation mode	CV, CC, and CP modes	
	Maximum number of programs	30	
	Maximum number of steps	10000	
	Step execution time	1 ms to 3600000 s	
	Loop count	1 to 100000, or infinite	
Output-on/off delay function	Setting range	0.0 s to 99.9 s	
	Setting resolution	0.1 s	
Over current protection (OCP) delay function	Setting range	1 ms to 2000 ms	
	Setting resolution	1 ms	
Multichannel (VMCB) function	Connection between the master unit and a PC	LAN, USB, RS232C	
	Connection with slave units	LAN	
Measurement trigger	Measurement start condition (trigger source)	Conditions for starting measurement can be selected (when inputting from display, when inputting commands by remote control, when inputting signals by external control, and when operating in synchronization)	
	Number of measurements	1 to 65536	
	Measurement delay time	Setting range	0 s to 100 s
		Setting resolution	0.1 ms
	Measurement interval	Setting range	0.1 ms to 3600 s
		Setting resolution	0.1 ms
	Measurement time	Setting range	0.1 ms to 1 s
Setting resolution		0.1 ms	
I-V characteristic function	Operation mode	CV/CC mode	
	Number of setup items	3 to 100 items (interpolated between points with straight lines)	
Preset value Memory	Number of memory entries	20	
	Saved setting	Values in CV, CC, and CP modes, protection function values, IR values, bleeder, and output delay setting.	
Setup Memory	Number of memory entries	21	
	Saved setting	Refer to Setup Memory ( <a href="#">p.99</a> )	
Key Lock	Level 1	Output on/off and preset memory recall are available	
	Level 2	Output on/off are available	
	Level 3	Output off is available	
Number of units in parallel operation		Up to 10 units	

# General Specifications

Item	PXT20K-500	PXT20K-1000	PXT20K-1500
Weight	Approx. 38 kg (83.78 lbs)	Approx. 38 kg (83.78 lbs)	Approx. 37 kg (81.57 lbs)
Dimensions	Refer to Outline Drawing (p.189)		
Environmental conditions	Operating environment	Indoor use, Overvoltage category II	
	Operating temperature	0 °C to +50 °C (32 °F to +122 °F)	
	Operating humidity	20 % rh to 85 % rh (no condensation)	
	Storage temperature	-25 °C to +60 °C (-13 °F to +140 °F)	
	Storage humidity	90 % rh or less (no condensation)	
	Altitude	Up to 2000 m	
Cooling system	Forced air cooling using fan		
Accessories	Refer to Accessories (p.8)		
Withstand voltage	Between input and GND	2200 Vac for 1 minute	
	Between input and output	2200 Vac for 1 minute	
	Between output and GND	1800 Vdc for 1 minute	1800 Vdc for 1 minute
Insulation resistance	Between input and GND	30 MΩ, 500 Vdc	
	Between input and output	30 MΩ, 1000 Vdc	
Isolation voltage	±1000 V	±1000 V	+2000 V/-1000 V
Electromagnetic compatibility (EMC) <sup>1 2</sup>	Complies with the requirements of the following directive and standards. EMC Directive 2014/30/EU EN 61326-1 (Class A <sup>3</sup> )		
Safety <sup>1</sup>	Complies with the requirements of the following directive and standards. Low Voltage Directive 2014/35/EU <sup>2</sup> EN 61010-1 (Class I <sup>4</sup> , Overvoltage category II, Pollution Degree 2 <sup>5</sup> )		

1. Does not apply to specially ordered or modified products.
2. Only for models with CE marking / UKCA marking on their body.
3. This is a Class A instrument. This product is intended for use in an industrial environment. This product may cause interference if used in residential areas. Such use must be avoided unless the user takes special measures to reduce electromagnetic emissions to prevent interference to the reception of radio and television broadcasts.
4. This is a Class I instrument. Be sure to ground this product's protective conductor terminal. The safety of this product is guaranteed only when the product is properly grounded.
5. Pollution is addition of foreign matter (solid, liquid or gaseous) that may produce a reduction of dielectric strength or surface resistivity. Pollution Degree 2 assumes that only non-conductive pollution will occur except for an occasional temporary conductivity caused by condensation.

# Outline Drawing

## PXT20K-500, PXT20K-1000, PXT20K-1500

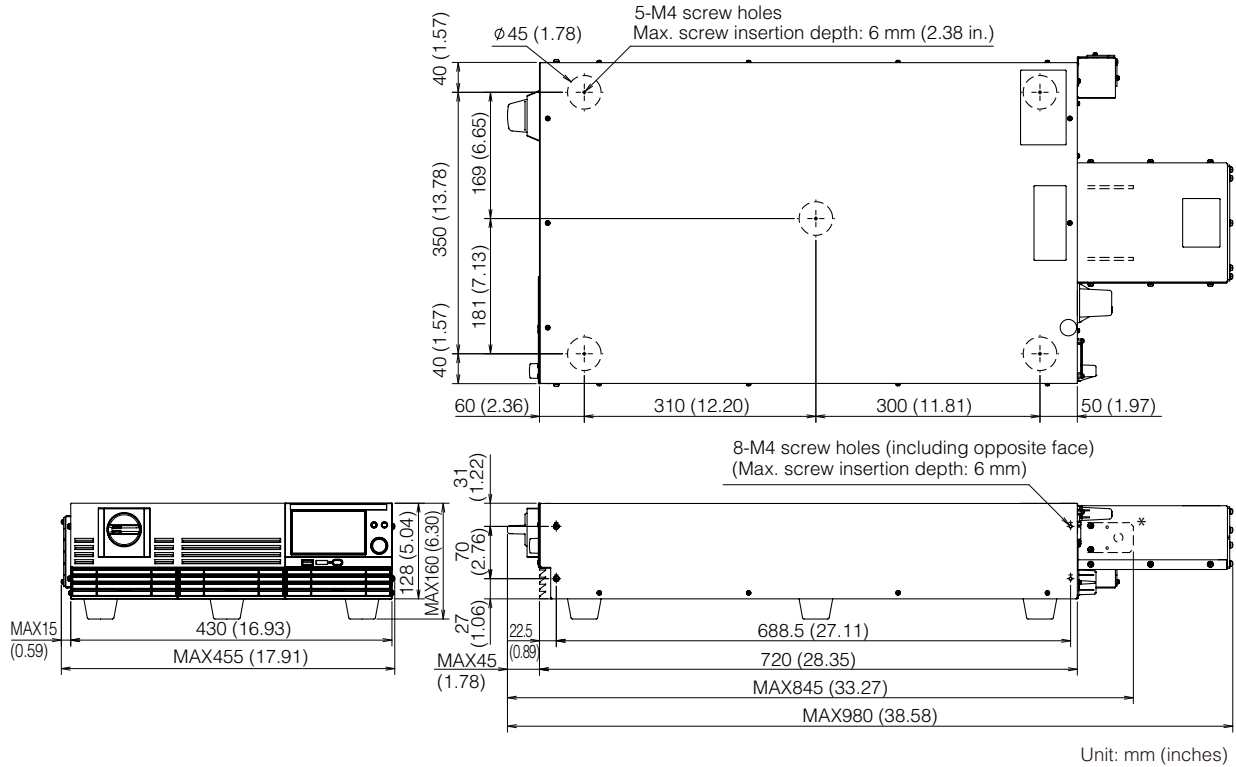

\*. The number of bus bars varies depending on the model.

## Settings at Factory Default and at Reset

Indicate the settings at factory default and reset. All items that have the ✓ mark in the “Reset” column are returned to their factory default values upon reset.

Item	Display	Factory default	Resetting		
Voltage	–	0 V	✓		
Current	–	0 A	✓		
Power	–	Maximum value (105 % of rating)	✓		
Response (CV)	Response CV	FAST	✓		
Response (CC)	Response CC	FAST	✓		
Slew rate (CV)	Slew Rate CV	PXT20K-500: 25 V/ms PXT20K-1000: 50 V/ms PXT20K-1500: 75 V/ms	✓		
Slew rate (CC)	Slew Rate CC	PXT20K-500: 6 A/ms PXT20K-1000: 3 A/ms PXT20K-1500: 1.5 A/ms	✓		
Priority operation mode	Priority when output is ON	CV	✓		
Bleeder	Bleeder	Enable	✓		
Output-on delay	Output ON Delay	0 s	✓		
Output-off delay	Output OFF Delay	0 s	✓		
I-V characteristics function	number of points	Count	3	✓	
	Set value of the 1st item	–	CV: Minimum current value, 0 V CC: Minimum voltage value, 0 A	✓	
	Set value of the 2nd item	–	0 A, 0 V	✓	
	Set value of the 3rd item	–	CV: Maximum current value, 0 V CC: Maximum voltage value, 0 A	✓	
Output mode	Output Mode	DC in all operation modes	✓		
Internal resistance function	Offset voltage	Offset Volt	0 V	✓	
	Resistance	IR	0 mΩ	✓	
Protection function	Overvoltage protection	OVP	Maximum value (110 % of rating)	✓	
	Undervoltage protection	UVP	Disabled, 0 V	✓	
	Overcurrent protection	Current	OCP	Maximum value (110 % of rating)	✓
		Delay time	Delay	1 ms	✓
	Overpower protection	OPP	Maximum value (120 % of rating)	✓	
	Grid overvoltage protection	Line OVP	Maximum value (107.5 % of the nominal maximum input rating)	✓	
	Communication error protection	WDog	Disabled, 60 s	–	
Measurement trigger	Trigger source	Source	IMM	✓	
	Number of times of recording	Count	1	✓	
	Delay time	Delay	0 s	✓	
	Recording time	Average	100 ms	✓	
	Recording interval	Timer	100 ms	✓	
	Enable/Disable of recording interval	Enable	Enable	✓	

Item	Display	Factory default	Resetting	
Integration	Period	Gate	Output ON	✓
	Reset method	Reset	Auto	✓
Remote sensing	RMT Sensing	Disable	–	
Preset value Memory	Confirmation at the time of recalling	Preset Recall Conform	Enabled	–
	Memory content	Preset. 1, Preset. 2, Preset. 3	The saved set values (p.96) are reset to the factory defaults.	–
Setup memory	Resume, 1.info to 20.info	The saved set values (p.99) are reset to the factory defaults.	–	
Sequence	Select edit Program	No program	–	
Settings at startup	Power ON Setting	Resume	–	
Output state at startup	Power ON Output	SAFE	–	
External control	Output range of the voltage control signal	V MON Range	0-10 V	–
	Output range of the current control signal	I MON Range	0-10 V	–
	Input range of the voltage control signal	CV Range	0-10 V	–
	Input range of the current control signal	CC/CP Range	0-10 V	–
	Enable/disable of the digital input/output	–	Disable	–
	Filter for digital input	Filter	FAST	–
	Polarity for digital input	Polarity	Positive	–
	Function for digital input	DIGI IN Channel	All OFF	–
	Polarity for digital output	Polarity	Positive	–
	Function for digital output	DIGI OUT Channel	All OFF	–
System setting	LAN communication setting	IP Address assignment method	AUTO	✓
		Desired Hostname	Factory default is model name and serial number.	–
		Desired Description	Factory default setting: KIKUSUI <name> Regulated DC Power Supply -<serial> <name>: model name, <serial>: serial number	–
		Dynamic DNS	Enable	✓
		mDNS	Enable	✓
	RS232C communication setting	Data Bits	8 bit (fixed)	–
		Parity	None (fixed)	–
		Stop Bits	1 bit (fixed)	–
		Bitrate	19200	–
		Flow Control	None	–
	Multichannel	VMCB	Disable	–
	Key lock	Lock Key Level	Disabled, Level 3	–
	Buzzer sound	Buzzer	Protection, SCPI, and KEY are all enabled	–
	Screen brightness	Brightness	Maximum value	–
	Setting the Date/Time	NTP Server	ntp.nict.jp	–
		Hostname		–
		Auto Clock Adjustment	Disable	–
Time Zone		UTC	–	
Manual Time		Not initialized	–	

# Selecting the Load Cables

## WARNING

### Risk of fire.

- Use load cables having strong flame-resistant insulation with sufficient margin for the current.

### Risk of electric shock.

- For load cables, use cables whose rated voltage is higher than the isolation voltage of PXT series.

## ■ Current capacity of load cables

A cable's temperature is determined by the resistive loss based on the current, the ambient temperature, and the cable's external thermal resistance. The following table shows the current capacity of heat-resistant vinyl cables that have a maximum allowable temperature of 60 °C when one of the cables is separated and stretched out horizontally in air in an ambient temperature of 30 °C. The current must be reduced under certain conditions, such as when vinyl cables that have a low heat resistance are used, when the ambient temperature is 30 °C or greater, or when cables are bundled together and little heat is radiated.

Nominal cross-sectional area [mm <sup>2</sup> ]	AWG	(Reference cross-sectional area; mm <sup>2</sup> )	Allowable current <sup>1</sup> [A] (Ta = 30 °C)	Kikusui-recommended current [A]
3.5	12	(3.31)	37	–
5.5	10	(5.26)	49	20
8	8	(8.37)	61	30
14	6	(13.3)	88	50
22	4	(21.15)	115	80
30	2	(33.62)	139	–
38	1	(42.41)	162	100
50	1/0	(53.49)	190	–
60	2/0	(67.43)	217	–
80	3/0	(85.01)	257	200

1. Excerpt from Japanese laws related to electrical equipment.

## ■ Taking measures against noise

When connecting cables that have the same heat resistance, separating the cables as much as possible to increase heat radiation enables a greater amount of current to flow. However, wiring the positive (+) and negative (–) output wires of the load cable side by side or bundling them together is more effective against unwanted noise. The Kikusui-recommended currents shown in the above table are allowable currents that have been reduced in consideration of the potential bundling of load cables. Use these values as a guideline when connecting cables.

## ■ Limitations of the remote sensing

All wires have resistance. As the cable becomes longer or the current becomes larger, the voltage drop in the cable becomes greater. This results in a smaller voltage applied to the DUT. The sensing function of this product compensates for the voltage drop up to 10 % (p.70) If the voltage drop exceeds this level, use cables that have a greater cross-sectional area.

## Guide for Required Time for Residual Voltage Discharge

A residual charge may exist in the DC OUTPUT terminal in the following cases: Do not touch the DC OUTPUT terminal until the residual voltage is discharged.

- The product is turned off due to the HIGH alarm.
- After the POWER switch of PXT series or the output is turned off while a non-voltage generator (capacitor, etc.) is connected as DUT when the bleeder (p.44) is set to disabled.
- When the LUVF alarm occurs while the output from the DC OUTPUT terminal is on under the setting of the slowest slew rate (p.74) when the bleeder (p.44) is set to enabled.

The time required for discharge depends on the capacitance of the DUT. The graphs below represent the time required for the product internal voltage to drop to 10 % of the output voltage setting when the PXT series power is off or when the output from the DC OUTPUT terminal is off.

### ■ PXT20K-500

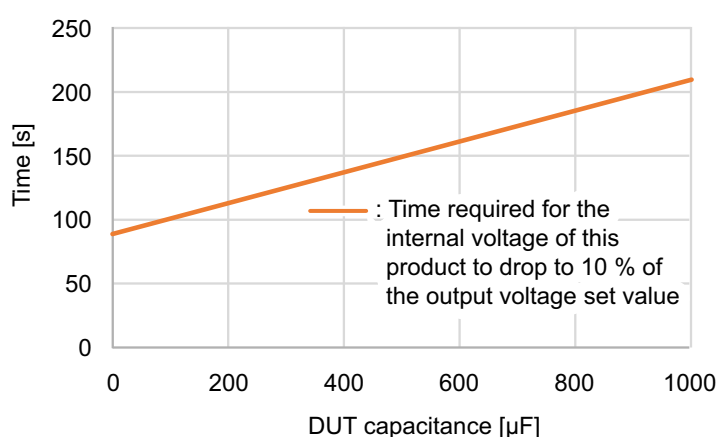

### ■ PXT20K-1000

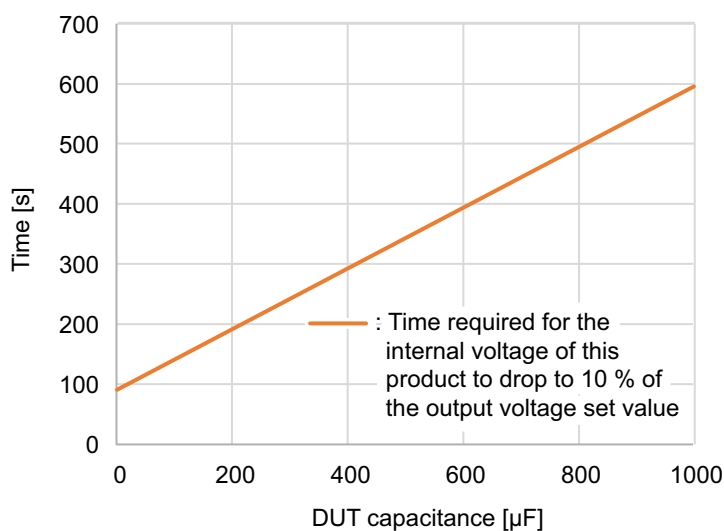

■ PXT20K-1500

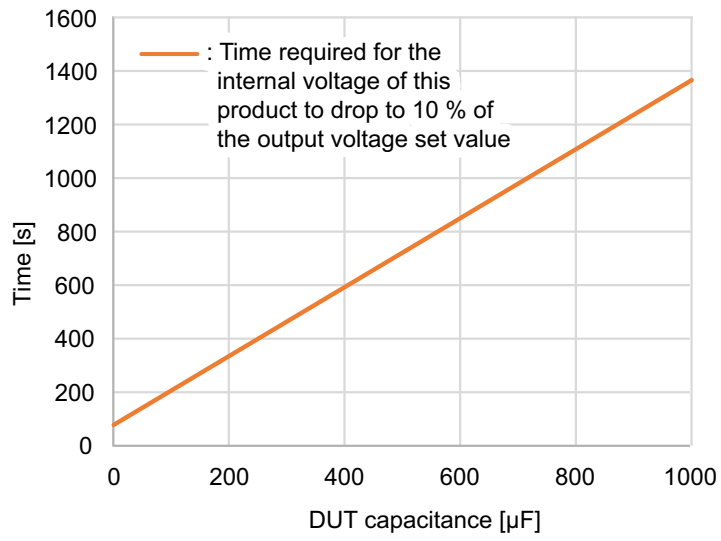

## Discharge Capacity after Output OFF Operation

The discharge capacities for 30 seconds after turning the output off when capacitive load is connected to DUT while bleeder (p.44) is enabled are as follows:

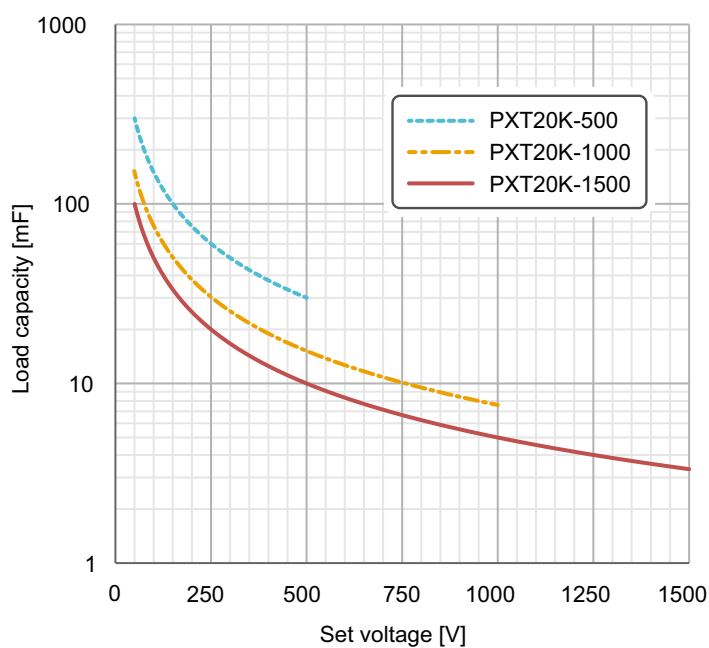

# Setting Range and Resolution During Parallel Operation

## Setting range during parallel operation

### CV setting range

As standalone operation, the minimum value is 0 V, and the maximum value is the maximum settable voltage.

### CC setting range

The minimum value is 0 A. The maximum value is the maximum settable current in standalone operation × the number of units including the master unit.

### CP setting range

The minimum value is 0 W. The maximum value is the maximum settable power in standalone operation × the number of units including the master unit.

### IR setting range

Number of slaves	PXT20K-500 (mΩ)	PXT20K-1000 (mΩ)	PXT20K-1500 (mΩ)
1	0 to 2625	0 to 10500	0 to 31500
2	0 to 1750	0 to 7000	0 to 21000
3	0 to 1312	0 to 5250	0 to 15750
4	0 to 1050	0 to 4200	0 to 12600
5	0 to 875	0 to 3500	0 to 10500
6	0 to 750	0 to 3000	0 to 9000
7	0 to 656	0 to 2625	0 to 7875
8	0 to 583	0 to 2333	0 to 7000
9	0 to 525	0 to 2100	0 to 6300

### Voltage slew rate switching

Four-step switching is available as standalone operation. Each voltage slew rate value is the same as in standalone operation.

### Current slew rate switching

Four-step switching is available as standalone operation. Each current slew rate value is the slew rate value in standalone operation × the number of units including the master unit.

## Setting resolution during parallel operation

### Output power setting resolution

Number of slaves	Common to all models (W)
1	5
2	5
3	10
4	10
5	10
6	10
7	20
8	20
9	20

### Output current setting resolution

Number of slaves	PXT20K-500 (A)	PXT20K-1000 (A)	PXT20K-1500 (A)
1	0.02	0.01	0.005
2	0.05	0.02	0.01
3	0.05	0.02	0.01
4	0.05	0.02	0.01
5	0.05	0.05	0.02
6	0.1	0.05	0.02
7	0.1	0.05	0.02
8	0.1	0.05	0.02
9	0.1	0.05	0.02

## Options

This product has the following options.  
For information about options, contact your Kikusui agent or distributor.

### Load cable

Cable type	Length	Maximum allowable current	Terminal size	Applicable models
DC80-2P3M-M10M10	3 m	200 A	M10/M10	PXT20K-500
HV22-2P3M-M12M8	3 m	80 A	M12/M8	PXT20K-1000, PXT20K-1500

### Three-phase input power cord

The switchboard ends of the power cords have not been prepared for connection.

Model: AC22-4P3M-M6C-4S

Length: 3 m

Nominal cross-sectional area: 22 mm<sup>2</sup> (AWG4)

Terminal size: M6

### Parallel operation signal cable kit

This kit contains a signal cable for performing parallel operation on the PXT series.

Model: PC01-PXB

Cable length: 1.5 m

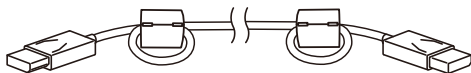

## Rack mount bracket

These are rack mounting options.

- KRB3-TOS: EIA inch rack standard
- KRB150-TOS: JIS millimeter rack standard

Remove the feet attached to the bottom face of the body when installing in a rack.

### NOTE

If you install PXT series into the rack, allow adequate clearances between other products so that it can operate within the operating temperature range ([p.188](#)).

### Outline drawing

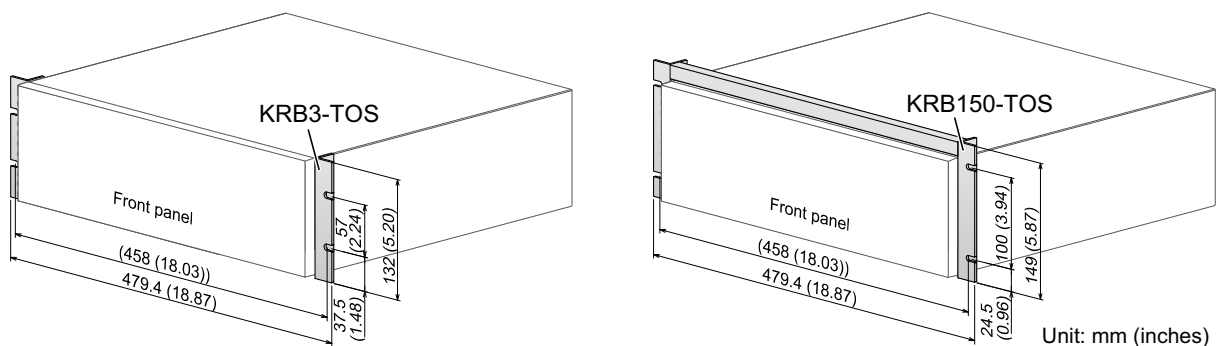

### Removing the feet

Remove the feet to install a rack mount bracket. For information on rack mounting, see the operation manual of the rack mount bracket.

### NOTE

We recommend that you keep all pieces that you remove from the product. You will need these pieces if you remove the product from the rack.

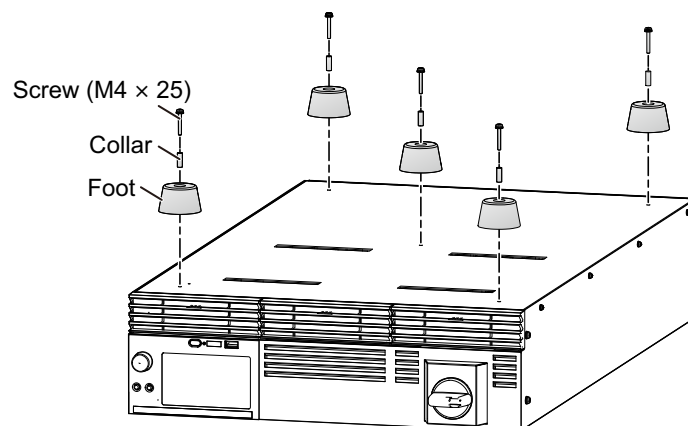

## GPIB converter (PIA5100)

This converter converts RS232C or USB of the product to GPIB, enabling connection of a remote controller using GPIB. Perform the connection as shown below.

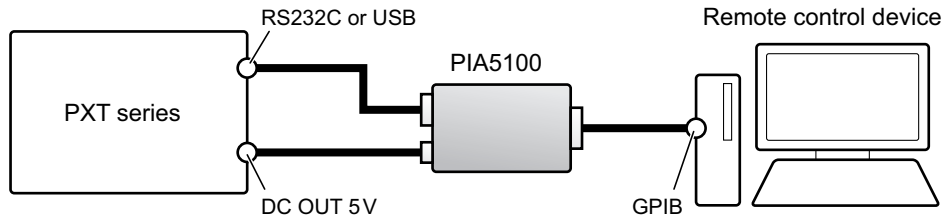

The GPIB communication specifications are as follows.

Item	Specifications
Hardware	Complies with IEEE Std 488.1-1987 SH1, AH1, T6, L4, SR1, PP0, DC1, DT1, C0, E1
Message terminator	LF or EOI during reception, LF + EOI during transmission
Primary address	0 to 30

Some restrictions apply to the GPIB functions that can be used with the PIA5100.

When the PXT series and the PIA5100 are connected via RS232C, they are compatible with the KISTD SAFU protocol, which can remove restrictions on GPIB functions.

For details, see the GPIB converter (PIA5100) operation manual.

# Troubleshooting















This section introduces troubleshooting measures. Typical symptoms are listed. Check whether any of the items listed below apply to your case. In some cases, the problem can be solved quite easily.

If none of the items apply to your case, we recommend that you initialize the product to its factory default settings (p. 167). If following the remedy does not solve your problem, contact your Kikusui agent or distributor.

## ■ Nothing appears on the display when the POWER switch is turned on.

Check	Possible cause	Remedy
Is the rated voltage being applied to the input power supply (AC)?	The power cord is broken. Bad connection at the rear-panel AC INPUT terminal.	Check that the power cord is not broken and that the connection at the AC INPUT terminal is secure.

## ■ Keys do not work.

Check	Possible cause	Remedy
Are the keys locked? (  /  /  are shown on the display.)	The keys are locked (p. 159).	Press and hold the key lock icon (  /  /  ) to release the key lock.
Are the keys locked? (  is shown on the display.)	Key lock is active on a slave unit for parallel operation.	Press and hold the key lock icon (  ) to release the key lock.
Are the keys locked by remote control? (  /  /  are shown on the display.)	 It is set to REMote by the RLST command under remote control.	Press and hold the key lock icon (  ) to release the key lock. <sup>1</sup>
	 It is set to RWLock by the RLST command under remote control.	<ul style="list-style-type: none"> <li>• Turn off the power to the PXT series unit and turn it on again to release the RWLock.</li> <li>• Set to LOCAL by the RLST command under remote control to release the lock. For details, see the Communication Interface Manual.</li> </ul>
	 It is set to LWLock. The possible causes are as follows. <ul style="list-style-type: none"> <li>• The USB cable connection signal stopped during the RWLock status when using the USB interface.</li> <li>• Sent a Go To Local command by VISA during the RWLock status.</li> </ul> For details, see the Communication Interface Manual.	<ul style="list-style-type: none"> <li>• Turn off the power to the PXT series unit and turn it on again to release the LWLock.</li> <li>• Send an arbitrary command by remote control to return to RWLock.</li> </ul>

1. If Web browser interface display and command transmission through a USB connection are performed simultaneously, pressing and holding the icon does not release the key lock (p. 160).

### ■ Set values cannot be changed.

Check	Possible cause	Remedy
Is "External" displayed on the field for output set value?	The output set value cannot be changed under an external control.	"Setting the Output Mode" (p. 46) and set a control method other than external controls.
Does it return to the original setting after entering a set value?	Preset memory is being recalled by an external control.	If a preset memory is recalled via the general-purpose digital input under an external control, turn off the signal (p. 140). When the signal is turned on, the set value is constantly recalled. So, even if the setting is changed, it will be overwritten by the contents of the preset memory.

### ■ Output current is unstable or oscillates.

Check	Possible cause	Remedy
Is the rated voltage being applied to the input power supply (AC)?	Supply voltage is dropping.	Use the product in the input supply voltage range.
Is an alarm occurring?	There is an internal or external error.	Check the type of alarm, and eliminate the root cause of the alarm (p. 58).
Is there a large loop in the load cable?	The wire inductance has increased.	Twist the wires.
Is the response setting suitable?	The response is too fast or too slow.	Change the response setting (p. 73).





### ■ Alarms cannot be cleared.

Check	Possible cause	Remedy
Has overheat detection (OHP) been activated?	The fan has stopped.	Stop use immediately, and contact your Kikusui agent or distributor.
	Vent or inlet holes are blocked.	Move the product so that there is at least 50 cm of space between the vents and the surrounding walls. Do not place objects within 50 cm of the vents.
	The internal temperature has not dropped.	Turn off the output from DC OUTPUT and leave it for 10 minutes with power on.
Is a hardware error (ERRH) alarm generated?	A problem occurred in PXT series hardware.	If the alarm continues after turning off and then on the power of PXT series, contact your Kikusui agent or distributor.
Is a software error (ERRS) alarm generated?	A problem occurred in PXT series software.	

### ■ The output cannot be turned on.

Check	Possible cause	Remedy
Are you using an external control signal to turn the output off?	The OUTPUT key is disabled when the output is turned off by an external control.	Turn off the OUTPUT OFF signal of the EXT CONT connector to enable the OUTPUT key (p. 140).

### ■ The output cannot be turned off.

Check	Possible cause	Remedy
Are the keys locked by remote control? (Remote / LWS / LWS icons are shown on the display.)	 It is set to REMote by the RLST command under remote control.	Press and hold the key lock icon (  ) to release the key lock. <sup>1</sup>
	 It is set to RWLock by the RLST command under remote control.	Turn off the power to the PXT series unit and turn it on again to release the RWLock. Set to LOCAL by the RLST command under remote control to release the lock. For details, see the Communication Interface Manual.
	 It is set to LWLock. The possible causes are as follows. The USB cable connection signal stopped during the RWLock status when using the USB interface. Sent a Go To Local command by VISA during the RWLock status. For details, see the Communication Interface Manual.	Turn off the power to the PXT series unit and turn it on again to release the LWLock. Send an arbitrary command by remote control to return to RWLock.

1. If Web browser interface display and command transmission through a USB connection are performed simultaneously, pressing and holding the icon does not release the key lock (p.160).

### ■ USB memory device is not recognized

Check	Possible cause	Remedy
What is the capacity and file system of the USB memory device?	A USB memory device that is not supported by the PXT series is being used.	Use the following USB memory devices. Capacity: 16 GB or less File System: FAT32

### ■ The start of PXT series is slow

Check	Possible cause	Remedy
How many numbers of steps of total program are there in total?	When the total number of steps of all programs becomes large, it will take longer time to turn the power supply of the PXT series on (as a reference, it takes about 15 minutes for 10,000 steps).	Delete unnecessary steps.

# Index

## A

accessories .....	8
alarm occurrence .....	67

## B

battery replacement .....	174
Bleeder .....	44
buzzer sound .....	161

## C

calibration .....	174
chain .....	121
communication error protection .....	66
Component Names .....	13

## D

date and time setting	
time setting .....	163
default settings .....	190
device information .....	158
DUT .....	27

## E

EXT CONT connector .....	128, 133
external control .....	127

## F

factory default settings .....	190
factory default settings, restoring .....	167, 168
firmware version .....	158
function list .....	36

## G

grid overvoltage protection .....	65
-----------------------------------	----

## I

I-V Characteristic .....	78
--------------------------	----

## K

key lock .....	159
----------------	-----

## L

LAN settings .....	149
lock .....	159
LOVP .....	65

## M

Memory .....	95
--------------	----

menu commands .....	40
menu list .....	36
Multichannel .....	154

## N

Not Measurable .....	42
NTP server .....	163

## O

OCP .....	63
operation mode .....	43
OPP .....	64
outline drawing .....	189
Output Delay .....	75
OUTPUT key .....	40
Output ON / OFF .....	40
OUTPUT terminal cover .....	22, 31
Over Range .....	42
overcurrent protection .....	63
overpower protection .....	64
overvoltage protection .....	61
OVP .....	61

## P

panel operation .....	35
panel settings at startup .....	76
parallel operation .....	90
power on/off .....	24
POWER switch .....	24
Preset Memory .....	96
problems and causes .....	201
Program .....	107
Protection .....	58, 93
protection plate .....	20, 133

## R

Remote sensing .....	70
Reset .....	168
reset settings .....	190
Resetting .....	169
response speed .....	73
RS232C settings .....	152

## S

-S .....	70
+S .....	70
Sanitize .....	167
SCPI error .....	170

screen brightness .....	162
sensing cable .....	70
Sequence .....	105
Serial number .....	15
Setup Memory .....	99
Slew Rate .....	74
sound .....	161
specifications .....	177
Steps .....	113
Swipe .....	35
Synchronized Operation .....	85
system settings .....	148

## T

The serial number .....	15
time zone .....	164
Touch panel display .....	14, 35
troubleshooting .....	201

## U

Under Range .....	42
undervoltage protection .....	62
updating .....	166
USB .....	13, 99, 125, 166
UVP .....	62

## V

version .....	158
VMCB .....	154

## W

watchdog .....	66
WDOG .....	66



## Warranty Period

Before delivery, our products have undergone strict testing and inspections and have been found to comply with the specifications. We offer different warranty periods for different product models. If the product should become defective within the specific warranty period applied to the product model after the date of purchase, we will repair the product or replace it with a new one for free. In a case in which the customer concluded a separate agreement with us regarding the warranty period, the conditions of the warranty period are applied based on such agreement.

## Scope of Warranty

If the product should become defective within the warranty period, we will repair the product or replace it with a new one. However, the warranty does not cover:

- Failure or damage caused by use that is not in accordance with the Operation Manual, misuse, or neglect.
- Failure or damage during transportation after delivery.
- Failure or damage caused by improper modification, adjustment, or repair.
- Failure or damage caused by an Act of God, fire, or other events beyond our control.
- Failure or damage caused by use in a corrosive atmosphere, a dusty environment, or an environment where salt damage occurs or contamination by liquid or foreign matters is likely to occur.
- Failure or damage due to causes that are not attributable to us.

## Disclaimer

Regardless of the warranty period, in no event shall we be liable for loss of opportunity or profit caused by the failure of our product, or initial or secondary damages, accident compensation, damages to products other than our products, or compensation for other operations caused by unavoidable circumstances that we may or may not have foreseen.

If you find any misplaced or missing pages in the manuals, they will be replaced. If the manual gets lost or soiled, a new copy can be provided for a fee. In either case, please contact your Kikusui agent or distributor. At that time, inform your agent or distributor of the "Part No." written on the front cover of this manual.

Every effort has been made to ensure the accuracy of this manual. However, if you have any questions or find any errors or omissions, please contact your Kikusui agent or distributor.

After you have finished reading this manual, store it so that you can use it for reference at any time.

## KIKUSUI ELECTRONICS CORP.

---

1-1-3 Higashiyamata, Tsuzuki-ku, Yokohama,  
224-0023, Japan

Phone: +81-45-482-6353

Facsimile: +81-45-482-6261

[global.kikusui.co.jp](http://global.kikusui.co.jp)

